



FOLDING PLATFORM TROLLEY

EN

Original Instructions
Version 2 – May 2024

04692 – FRT300 ASSEMBLY INSTRUCTIONS

Read this manual in full before using this product and retain it for future use. Always use the latest version of the manual. For the latest version of this manual please visit drapertools.com/manuals

1. Specification

Stock No.	04692
Part No.	FRT300
Max. static load:	300kg
Max. dynamic load:	200kg approx.
Wheel diameter:	127mm
Dimensions:	L 910 x W 610 x H 870mm
Net weight:	11.5kg

2. Health and Safety Information

Important: Read these instructions before attempting to assemble, use or maintain this product. Failure to follow may result in injury or damage to the user, the product or the load.

- Keep your work area well lit, with bystanders at a safe distance.
- Assemble this product only in the manner depicted and do not modify the product in any way.

3. What's in the Box?

Carefully remove the product from the packaging and examine it for any signs of damage that may have occurred during shipment.

Before assembling the product, lay the contents out and check them against the parts shown below. If any part is damaged or missing, do not attempt to use the product. Please contact the Draper Helpline; contact details can be found at the back of this manual.

- Before every use, inspect the trolley for broken or cracked parts and loose fixtures.

 **WARNING! DO NOT use this product if any parts are damaged. Tighten, replace or repair all affected parts before use.**

- Only use this product on firm, level surfaces capable of supporting both the trolley and its load.
 - **DO NOT** use this product on sloped or slippery surfaces.
 - Where available, use ramps to mount kerbs and other raised edges.
- **DO NOT** ride on or allow others to ride on this product.
- **DO NOT** exceed the maximum rated capacities of this product.
- When in use, ensure that the load is distributed evenly and that the trolley is not overbalanced.
 - Be mindful of changes to the weight distribution when loading and unloading.
- **ALWAYS** ensure that the heaviest part of the load is flat against the trolley platform.
- Ensure that the load is stable and secure before transporting it.
- Manoeuvre the product using the handle **ONLY** and maintain full control of the trolley at all times.
 - This product is intended to be pushed; only pull if absolutely necessary.
- Plan your route and ensure that the castors are not obstructed before moving the trolley.
- **DO NOT** leave the trolley unattended while under load.

Please visit drapertools.com for our full range of accessories and consumables.

Keep the product packaging for the duration of the warranty period in case the product needs to be returned for repair.

 **WARNING! Keep packaging materials out of reach of children. Dispose of packaging correctly and responsibly and in accordance with local regulations.**

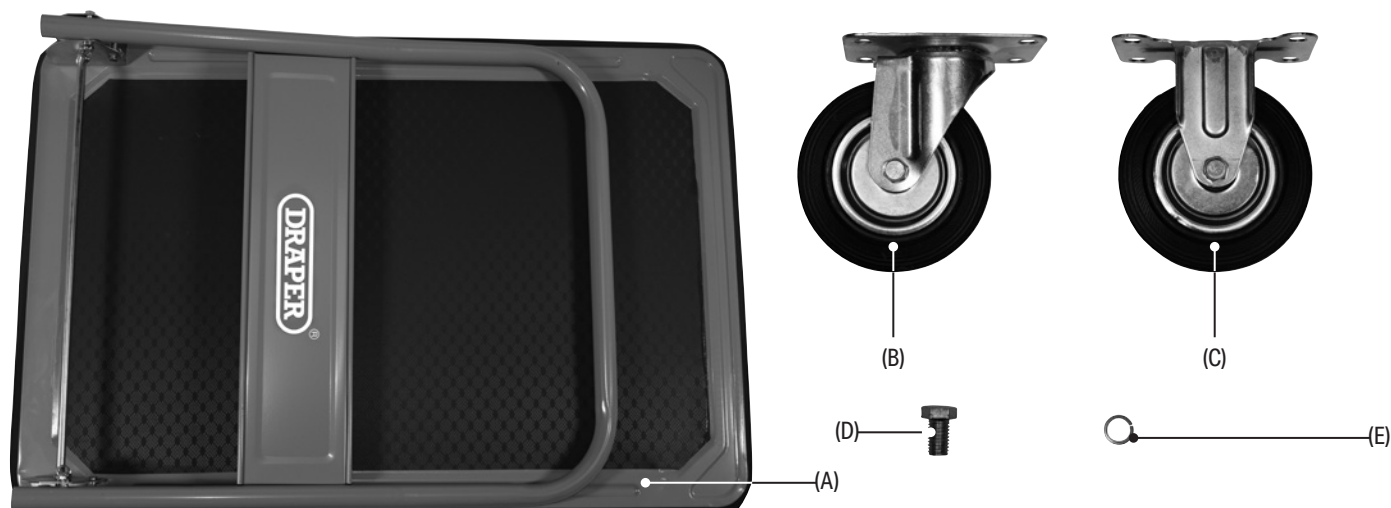

- A. 1 x Trolley platform
- B. 2 x Swivel castors

- C. 2 x Fixed castors
- D. 16 x M10 x 15mm hex bolts

- E. 16 x M10 spring washers

4. Assembly Instructions

Important: Before assembling this product, read and understand all the safety instructions listed in this manual. Screw all bolts finger-tight and tighten when assembly is complete.

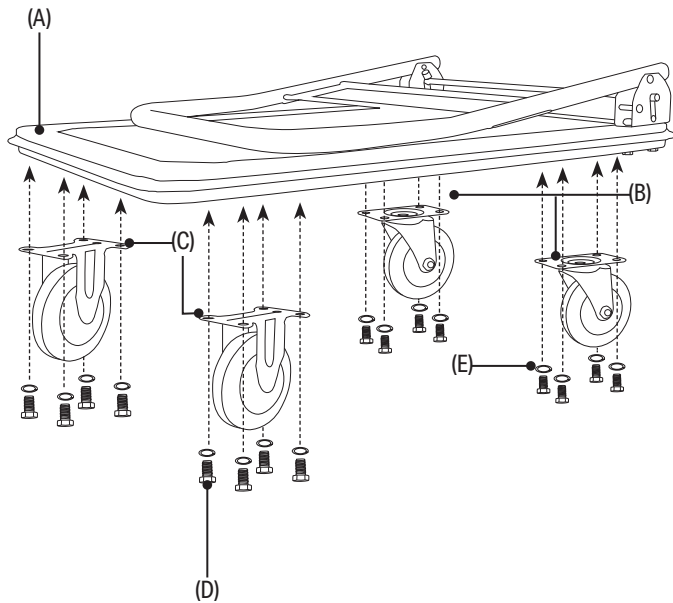

1. Position the trolley platform (A) upside down with the folded handle against the floor.
2. Use the M10 x 15mm hex bolts (D) and M10 spring washers (E) to attach the swivel castors (B) to the back of the trolley platform (where the handle is attached) and the fixed castors (C) to the front end.
3. Tighten all bolts, then turn the trolley over onto the castors and open the trolley handle.

Important: To prevent warping of the wheels, the swivel castors **MUST** be installed at the back of the trolley (beneath the handle).

5. Opening and Folding the Handle

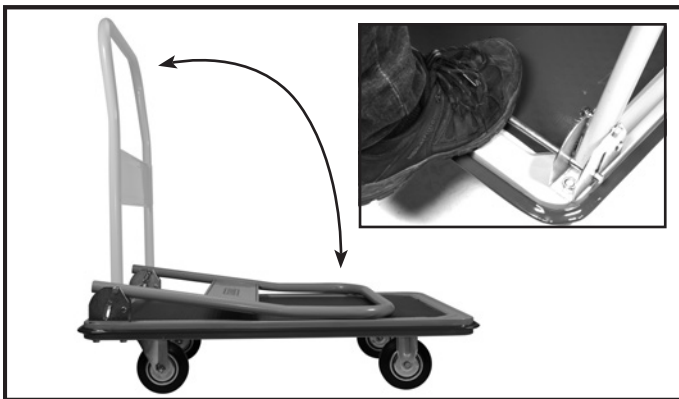

Fig.1

To open or fold the handle, press down on the locking bar with your foot and manoeuvre the handle to the desired position. Carefully release the locking bar when the desired position has been reached.

Important: The handle is not locked in position when folded away. Take care when transporting the trolley as the handle may swing open and cause injury.

6. Maintenance and Disposal

- Periodically check that all bolts are tightly secured and lubricate all moving parts.
- Store this product in a clean and dry environment, out of direct sunlight and out of reach of children.
- At the end of its working life, dispose of the product responsibly and in line with local regulations.
- Recycle where possible.

7. Warranty

Should the tool develop a fault, return the complete tool to your nearest distributor or contact Draper Tools directly. Proof of purchase must be provided.

If, upon inspection, it is found that the fault occurring is due to defective materials or workmanship, repairs will be carried out free of charge. This warranty covers parts and labour for 12 months from the date of purchase. However, if the tools are hired out, the warranty period is 90 days from the date of purchase.

This warranty does not apply to any consumable parts, batteries or normal wear and tear, nor does it cover any damage caused by misuse, careless or unsafe handling, alterations, accidents, or repairs attempted or made by any personnel other than the authorised Draper Tools repair agent.

For full details, visit drapertools.com/warranty

8. Explanation of Symbols



Read the instruction manual



Overall body length



Overall body width



Overall body height



Folded body height



Max. capacity on level ground