



**DRAPER**<sup>®</sup>

**STORMFORCE**

10.8V

# ROTARY MULTI-TOOL KIT

07849



These instructions accompanying the product are the original instructions. This document is part of the product, keep it for the life of the product passing it on to any subsequent holder of the product. Read all these instructions before assembling, operating or maintaining this product.

This manual has been compiled by Draper Tools describing the purpose for which the product has been designed, and contains all the necessary information to ensure its correct and safe use. By following all the general safety instructions contained in this manual, it will ensure both product and operator safety, together with longer life of the product itself.

All photographs and drawings in this manual are supplied by Draper Tools to help illustrate the operation of the product.

Whilst every effort has been made to ensure the accuracy of information contained in this manual, the Draper Tools policy of continuous improvement determines the right to make modifications without prior warning.

# 1. TITLE PAGE

---

## 1.1 INTRODUCTION:

**USER MANUAL FOR: 10.8V Rotary Multi-tool Kit**

**Stock No: 07849**

**Part No: CMG108SF/BMC**

## 1.2 REVISIONS:

**Date first published September 2021.**

---

---

---

---

As our user manuals are continually updated, users should make sure that they use the very latest version.

**Downloads are available from:** <http://drapertools.com/manuals>

Draper Tools Limited  
Hursley Road  
Chandler's Ford  
Eastleigh  
Hampshire  
SO53 1YF  
UK

Draper Tools Limited  
Oude Graaf 8  
6002 NL  
WEERT  
Netherlands

**Website:** [drapertools.com](http://drapertools.com)

**Product Help Line:** +44 (0) 23 8049 4344

**General Fax:** +44 (0) 23 8026 0784

## 1.3 UNDERSTANDING THIS MANUALS SAFETY CONTENT:

**Warning!** – Information that draws attention to the risk of injury or death.

**Important** – Information that draws attention to the risk of damage to the product or surroundings.

## 1.4 COPYRIGHT © NOTICE:

Copyright © Draper Tools Limited.

Permission is granted to reproduce this publication for personal and educational use only. Commercial copying, redistribution, hiring or lending is prohibited.

No part of this publication may be stored in a retrieval system or transmitted in any other form or means without written permission from Draper Tools Limited.

In all cases this copyright notice must remain intact.

## 2. CONTENTS

---

### 2.1 TABLE OF CONTENTS

#### 1. TITLE PAGE

1.1	INTRODUCTION.....	2
1.2	REVISIONS.....	2
1.3	UNDERSTANDING THIS MANUALS SAFETY CONTENT .....	2
1.4	COPYRIGHT © NOTICE.....	2

#### 2. CONTENTS

2.1	TABLE OF CONTENTS .....	3
-----	-------------------------	---

#### 3. WARRANTY

3.1	WARRANTY.....	4
-----	---------------	---

#### 4. INTRODUCTION

4.1	SCOPE.....	5
4.2	SPECIFICATION.....	5
4.3	HANDLING AND STORAGE.....	5

#### 5. HEALTH AND SAFETY INFORMATION

5.1	GENERAL SAFETY INSTRUCTIONS FOR POWER TOOL USE .....	6
5.2	ADDITIONAL SAFETY INSTRUCTIONS FOR MULTI-TOOL USE .....	7
5.3	RESIDUAL RISK.....	8
5.4	SAFETY INSTRUCTIONS FOR MAINS POWERED CHARGERS & BATTERY PACKS.....	8
5.5	CONNECTION TO THE POWER SUPPLY (CHARGER) .....	10

#### 6. TECHNICAL DESCRIPTION

6.1	IDENTIFICATION.....	11
-----	---------------------	----

#### 7. UNPACKING AND CHECKING

7.1	PACKAGING .....	12
7.2	WHAT'S IN THE BOX .....	12

#### 8. PREPARING THE ROTARY MULTI-TOOL

8.1	BATTERY PACK CHARGING – FIGS. 1 – 2 .....	13
8.2	BATTERY PACK CHARGE STATUS .....	13

#### 9. BASIC MULTI-TOOL OPERATIONS

9.1	SWITCHING ON AND OFF.....	14
9.2	VARIABLE SPEED CONTROL .....	14
9.3	FITTING ACCESSORIES .....	14
9.4	FITTING ACCESSORIES USING A MANDREL.....	14
9.5	HOLDING THE TOOL .....	14
9.6	ATTACHMENTS AND MACHINE SPEEDS .....	15
9.7	OPTIONAL ACCESSORIES .....	15

#### 10. DISPOSAL

10.1	DISPOSAL.....	16
10.2	BATTERY PACK DISPOSAL INFORMATION.....	16

#### 11. EXPLANATION OF SYMBOLS

11.1	EXPLANATION OF SYMBOLS.....	17
------	-----------------------------	----

## 3. WARRANTY

---

### 3.1 WARRANTY

Draper tools have been carefully tested and inspected before shipment and are guaranteed to be free from defective materials and workmanship.

Should the tool develop a fault, please return the complete tool to your nearest distributor or contact:

**Draper Tools Limited, Chandler's Ford, Eastleigh, Hampshire, SO53 1YF. England.**

**Telephone Sales Desk: +44 (0) 8049 4333 or Product Help Line +44 (0) 23 8049 4344.**

A proof of purchase **must** be provided with the tool.

If upon inspection it is found that the fault occurring is due to defective materials or workmanship, repairs will be carried out free of charge. This warranty period covering parts/labour is 24 months from the date of purchase except where tools are hired out when the warranty period is 90 days from the date of purchase. This warranty does not apply to any consumable parts, any type of battery or normal wear and tear, nor does it cover any damage caused by misuse, careless or unsafe handling, alterations, accidents, or repairs attempted or made by any personnel other than the authorised Draper warranty repair agent.

**Note:** If the tool is found not to be within the terms of warranty, repairs and carriage charges will be quoted and made accordingly.

This warranty applies in lieu of any other warranty expressed or implied and variations of its terms are not authorised.

Your Draper warranty is not effective unless you can produce upon request a dated receipt or invoice to verify your proof of purchase within the warranty period.

Please note that this warranty is an additional benefit and does not affect your statutory rights.

**Draper Tools Limited.**

## 4. INTRODUCTION

---

### 4.1 SCOPE

For drilling, milling, grinding, engraving, cutting, polishing, sharpening, buffing and removing rust, etc.

This product is intended for domestic and infrequent light trade use only. Any application other than that it was intended for, is considered misuse.

### 4.2 SPECIFICATION

Stock No. ....	07849
Part No. ....	CMG108SF/BMC
Speed (no load) .....	5,000 – 25,000r/min
Speed settings .....	6
Collet capacities: .....	1/32", 3/64", 1/16", 5/64", 3/32"
Collet nut .....	3/32"
Sound Pressure Level .....	63.2dB(A)
Sound Power Level .....	74.2dB(A)
Uncertainty (K) .....	3dB(A)
Vibration level .....	< 2.5m/s <sup>2</sup> , K=1.5m/s <sup>2</sup>
Weight .....	0.43kg
Battery pack:	
Stock No. ....	16254
Part No. ....	CB108LI
Type .....	Li-ion
Rated Voltage .....	10.8V
Rating .....	1.5Ah
Charger:	
Stock No. ....	16255
Part No. ....	C108LI
Rated Voltage .....	230V~
Rated Frequency .....	50Hz
Rated D.C. output voltage .....	10.8V
Rated D.C. output current .....	2.0A
Protective device rated current * .....	2A
Construction .....	Class II

\*Time delay.

### 4.3 HANDLING AND STORAGE

- Care must be taken when handling this product.
  - Dropping this power tool could have an effect on its accuracy and could also result in personal injury. This product is not a toy and must be respected.
- Environmental conditions can have a detrimental effect on this product if neglected.
  - Exposure to damp air can gradually corrode components. If the product is unprotected from dust and debris, components will become clogged.
  - If not cleaned and maintained correctly or regularly, the machine will not perform at its best.

# 5. HEALTH AND SAFETY INFORMATION

---

## 5.1 GENERAL SAFETY INSTRUCTIONS FOR POWER TOOL USE

**Warning! Read all safety warnings, instructions, illustrations and specifications provided with this power tool.** Failure to follow all instructions listed below may result in electric shock, fire and/or serious injury.

**Save all warnings and instructions for future reference.**

The term “power tools” in the warnings refers to your mains-operated (corded) power tool or battery-operated (cordless) power tool.

### 1) Work area safety

- a) **Keep work area clean and well lit.** Cluttered or dark areas invite accidents.
- b) **Do not operate power tools in explosive atmospheres, such as in the presence of flammable liquids, gases or dust.** Power tools create sparks which may ignite the dust or fumes.
- c) **Keep children and bystanders away while operating a power tool.** Distractions can cause you to lose control.

### 2) Electrical safety

- a) **Power tool plugs must match the outlet. Never modify the plug in any way. Do not use any adapter plugs with earthed (grounded) power tools.** Unmodified plugs and matching outlets will reduce risk of electric shock.
- b) **Avoid body contact with earthed or grounded surfaces, such as pipes, radiators, ranges and refrigerators.** There is an increased risk of electric shock if your body is earthed or grounded.
- c) **Do not expose power tools to rain or wet conditions.** Water entering a power tool will increase the risk of electric shock.
- d) **Do not abuse the cord. Never use the cord for carrying, pulling or unplugging the power tool. Keep cord away from heat, oil, sharp edges or moving parts.** Damaged or entangled cords increase the risk of electric shock.
- e) **When operating a power tool outdoors, use an extension cord suitable for outdoor use.** Use of a cord suitable for outdoor use reduces the risk of electric shock.
- f) **If operating a power tool in a damp location is unavoidable, use a residual current device (RCD) protected supply.** Use of an RCD reduces the risk of electric shock.

### 3) Personal safety

- a) **Stay alert, watch what you are doing and use common sense when operating a power tool. Do not use a power tool while you are tired or under the influence of drugs, alcohol or medication.** A moment of inattention while operating power tools may result in serious personal injury.
- b) **Use personal protective equipment Always wear eye protection.** Protective equipment such as a dust mask, non-skid safety shoes, hard hat or hearing protection use for appropriate conditions will reduce personal injuries.
- c) **Prevent unintentional starting. Ensure the switch is in the off-position before connecting to power source and/or battery pack, picking up or carrying the tool.** Carrying power tools with your finger on the switch or energising power tools that have the switch on invites accidents.
- d) **Remove any adjusting key or wrench before turning the power tool on.** A wrench or a key left attached to a rotating part of the power tool may result in personal injury.
- e) **Do not overreach. Keep proper footing and balance at all times.** This enables better control of the power tool in unexpected situations.

## 5. HEALTH AND SAFETY INFORMATION

---

- f) **Dress properly. Do not wear loose clothing or jewellery. Keep your hair and clothing away from moving parts.** Loose clothes, jewellery or long hair can be caught in moving parts.
- g) **If devices are provided for the connection of dust extraction and collection facilities, ensure these are connected and properly used.** Use of dust collection can reduce dust-related hazards.
- h) **Do not let familiarity gained from frequent use of tools allow you to become complacent and ignore tool safety principles.** A careless action can cause severe injury within a fraction of a second.

### 4) Power tool use and care

- a) **Do not force the power tool. Use the correct power tool for your application.** The correct power tool will do the job better and safer at the rate for which it was designed.
- b) **Do not use the power tool if the switch does not turn it on and off.** Any power tool that cannot be controlled with the switch is dangerous and must be repaired.
- c) **Disconnect the plug from the power source and/or remove the battery pack, if detachable, from the power tool before making any adjustments, changing accessories, or storing power tools.** Such preventive safety measures reduce the risk of starting the power tool accidentally.
- d) **Store idle power tools out of the reach of children and do not allow persons unfamiliar with the power tool or these instructions to operate the power tool.** Power tools are dangerous in the hands of untrained users.
- e) **Maintain power tools and accessories. Check for misalignment or binding of moving parts, breakage of parts and any other condition that may affect the power tool's operation. If damaged, have the power tool repaired before use.** Many accidents are caused by poorly maintained power tools.
- f) **Keep cutting tools sharp and clean.** Properly maintained cutting tools with sharp cutting edges are less likely to bind and are easier to control.
- g) **Use the power tool, accessories and tool bits etc. in accordance with these instructions, taking into account the working conditions and the work to be performed.** Use of the power tool for operations different from those intended could result in a hazardous situation.
- h) **Keep handles and grasping surfaces dry, clean and free from oil and grease.** Slippery handles and grasping surfaces do not allow for safe handling and control of the tool in unexpected situations.

### 5) Service

- a) **Have your power tool serviced by a qualified repair person using only identical replacements parts.** This will ensure that the safety of the power tool is maintained.

## 5.2 ADDITIONAL SAFETY INSTRUCTIONS FOR MULTI-TOOL USE

Safety warnings common for grinding, sanding, wire brushing, polishing, carving and cutting off operations:

**This power tool is intended to function as a grinder, sander, wire brush, polisher, carving or cut-off tool.** Read all safety warnings, instructions, illustrations and specifications provided with this power tool. Failure to follow all instructions listed below may result in electric shock, fire and/or serious injury.

**Do not use accessories which are not specifically designed and recommended by the tool manufacturer.** Just because the accessory can be attached to your power tool, it does not assure safe operation. The rated speed of the grinding accessories must be at least equal to the maximum speed marked on the power tool. Grinding accessories running faster than their rated speed can break and fly apart.

## 5. HEALTH AND SAFETY INFORMATION

---

**The outside diameter and the thickness of your accessory must be within the capacity rating of your power tool.** Incorrectly sized accessories cannot be adequately controlled.

**The arbour size of wheels, sanding drums or any other accessory must properly fit the spindle or collet of the power tool.** Accessories that do not match the mounting hardware of the power tool will run out of balance, vibrate excessively and may cause loss of control.

**Mandrel mounted wheels, sanding drums, cutters or other accessories must be fully inserted into the collet or chuck.** If the mandrel is insufficiently held and/or the overhang of the wheel is too long, the mounted wheel may become loose and be ejected at high velocity.

**Do not use a damaged accessory. Before each use inspect the accessory such as abrasive wheels for chips and cracks, sanding drum for cracks, tear or excess wear, wire brush for loose or cracked wires.** If power tool or accessory is dropped, inspect for damage or install an undamaged accessory.

### 5.3 RESIDUAL RISK

**Important:** Although the safety instructions and operating manuals for our tools contain extensive instructions of safe working with power tools, every power tool involves a certain residual risk which can not be completely excluded by safety mechanisms. Power tools must therefore always be operated with caution!

### 5.4 SAFETY INSTRUCTIONS FOR MAINS POWERED CHARGERS & BATTERY PACKS

#### Chargers

- The charger is for indoor use only.
- Prior to plugging the charger in to the supply, check that the plug and the cable are in good repair. If either are damaged, have the defective item replaced immediately by a suitably qualified person. If the casing of the battery charger is damaged, it is good policy to have the charger checked over by a suitably qualified person.
- Only use a correctly rated mains outlet to provide power, do not plug into site generators, attach to engine generators or D.C. sources. Do not use a mains socket outlet that is not switched.
- Use the correct Draper charger in conjunction with it's corresponding battery pack (consult the Draper website for more information or to find your local Draper stockist).
- Do not charge any other batteries with Draper chargers. Any other application is considered misuse.
- Do not attempt to charge battery packs that are too hot (over 30°C) or too cold (under 5°C), if these conditions apply set the battery pack aside to "normalise" before proceeding with the charging operation.
- Set up the charger and cable in a safe place where it won't be knocked, tripped over, stepped on, etc. and where it is well ventilated. Make sure the ventilation slots in the charger case are not obstructed, plug the charger into the socket outlet.
- Inspect the battery pack for damage, if it is undamaged, plug it into the charger, ensuring the correct orientation. (Most chargers and batteries have 'keys' etc, to make sure the battery pack is not inserted incorrectly, if you are having to 'force' the battery pack into the charger, the chances are you have it the wrong way round, check and try again.)
- Switch the charger on and check that the correct indicators illuminate, allow the battery pack to charge (see the specific instructions for your charger). Once charging is complete, switch the charger off, remove the battery pack and store, repeat the procedure if you have more than one battery pack to charge.



## 5. HEALTH AND SAFETY INFORMATION

---

**Caution:** When the battery charger has been continuously used, the battery charger will be hot. Once the charging has been completed, give 15 minutes rest until the next charge.

- After charging is complete, unplug the charger from the socket outlet by pulling on the plug. Do not pull on the cable. Store the charger in a dry secure place.
- If, when the charger was switched on, the correct indications did not occur, leave for two or three minutes to allow the charger to stabilise, if the correct indications occur, allow the charging cycle to proceed as normal. If no indication appears at all, switch off, remove the battery pack, unplug the charger, check that the charger contacts and the battery contacts are clean and repeat the process. If there is still no indication, switch off, remove the battery pack, unplug the charger and check the fuse. If the fuse is blown, replace and repeat the process. If the fuse blows again, or if the fuse was intact, attempt no further action. Refer the charger to a suitably qualified person for repair.

### **Battery packs**

- Before charging, read the instructions.
- For indoor use. Do not expose to rain.
- Do not charge any other manufacturer's battery packs using Draper chargers. Any other application is considered misuse.
- The battery must be removed from the appliance before it is recycled.– The charger must be disconnected from the supply mains when removing the battery.
- The battery is to be disposed of in-line with local authority procedures.
- Do not use any other than the designated Draper batteries/chargers with this product.
- Do not crush, open or burn the battery. Exposure to potentially harmful materials may occur.
- In case of fire use CO<sub>2</sub> or dry chemical extinguisher.
- Do not expose to high temperatures >50°C. The battery may degrade at high temperatures.
- Charge battery in conditions between 5°C to 30°C with the specified charger designed for this battery.
- Do not use battery if it has been stored at 5°C or less. Allow it to “normalise” at room temperature before usage/charging.

### **Warning! Leaking battery packs**

- The electrolyte in battery packs is corrosive. Avoid contact with the skin.
- If contact is made, flush the area with running water, pat dry and seek medical attention and advice at the earliest opportunity.
- Inform medical personnel that the contaminant is a “high alkaline, corrosive liquid”.
- If electrolyte comes into contact with the eyes, flush with copious amounts of water only. Seek medical attention immediately, relaying the information above.

## 5. HEALTH AND SAFETY INFORMATION

---

### 5.5 CONNECTION TO THE POWER SUPPLY (CHARGER)

**Caution:** Risk of electric shock. Do not open.

This appliance is supplied with a moulded 3 pin mains plug for your safety. The value of the fuse fitted is marked on the pin face of the plug.

Should the fuse need replacing, ensure the substitute is of the correct rating, approved to BS1362 and ASTA or BSI Kite marked.

ASTA 

BSI 

The fuse cover is removable with a small plain slot screwdriver. Ensure the fuse cover is replaced before attempting to connect the plug to an electrical outlet. If the cover is missing, a replacement must be obtained or the plug replaced with a suitable type.

If a replacement plug is to be fitted this must be carried out by a qualified electrician.

The damaged or incomplete plug, when cut from the cable should be disabled to prevent connection to a live electrical outlet.

This appliance is Class II<sup>†</sup> and is designed for connection to a power supply matching that detailed on the rating label and compatible with the plug fitted.

If an extension lead is required, use an approved and compatible lead rated for this appliance.

Follow all the instructions supplied with the extension lead.

<sup>†</sup>Double insulated : This product requires no earth connection as supplementary insulation is applied to the basic insulation to protect against electric shock in the event of failure of the basic insulation.

#### **Important**

**If using an extension lead, follow the instructions that came with your lead regarding maximum load while cable is wound. If in doubt, ensure that the entire cable is unwound. Using a coiled extension lead will generate heat which could melt the lead and cause a fire.**

## 6. TECHNICAL DESCRIPTION

### 6.1 IDENTIFICATION



- ① Spindle locking button.
- ② Variable speed control.
- ③ Battery charge level indicator.
- ④ 10.8V Draper Power Interchange Li-ion battery.

- ⑤ ON/OFF Switch.
- ⑥ Collet nut.

# 7. UNPACKING AND CHECKING

## 7.1 PACKAGING

Carefully remove the product from the packaging and examine it for any sign of damage that may have happened during shipping. Lay the contents out and check them against the parts shown below. If any part is damaged or missing, please contact the Draper Help Line (the telephone number appears on the Title page) and do not attempt to use the product.

The packaging material should be retained at least during the warranty period, in case the machine needs to be returned for repair.

### Warning!

- Some of the packaging materials used may be harmful to children. Do not leave any of these materials in the reach of children.
- If any of the packaging is to be thrown away, make sure they are disposed of correctly, according to local regulations.

## 7.2 WHAT'S IN THE BOX

As well as the main product, there are several parts not fitted or attached to it.



④ 10.8V Draper Power Interchange Li-ion battery.

⑦ 230V 'Fast' charger

⑨ 5 × Grinding points.

⑩ 2 × Milling bits

⑪ 3 × Engraving bits.

⑫ 1 × Bristle brush.

⑬ 1 × Bristle wheel.

⑭ 1 × Brass wheel.

⑮ 6 × HSS drill bits.

⑯ 4 × Grinding discs.

⑰ 3 × Polishing discs.

⑱ 16 × Cutting discs.

⑲ 5 × Collets: 1/32", 3/64", 1/16", 5/64", 3/32"

⑳ 2 × Mandrels.

㉑ Combination spanner/screwdriver.

Note: For details of our full range of accessories and consumables, please visit [drapertools.com](http://drapertools.com)

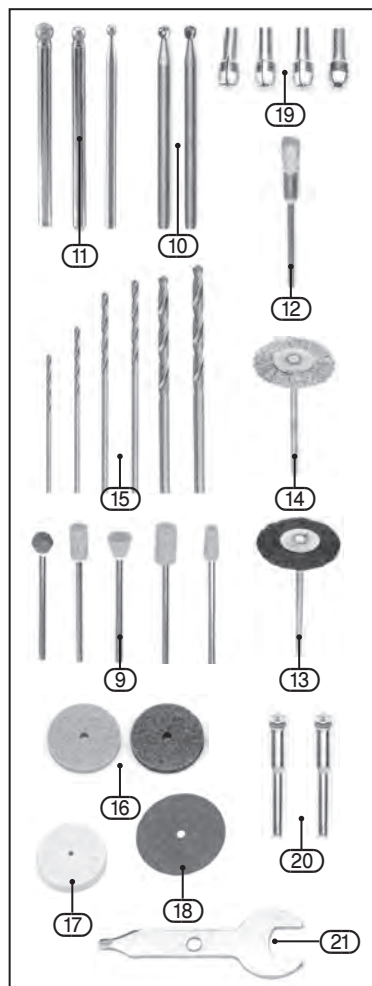

## 8. PREPARING THE ROTARY MULTI-TOOL

### 8.1 BATTERY PACK CHARGING – FIGS. 1 – 2

**Important:** Only Draper designated battery packs and chargers can be used in conjunction with this product. Use of any other third party battery packs/chargers with this product is considered misuse and will invalidate the product's warranty.

Once connected to the mains supply, recharging of the battery can be left generally unsupervised, requiring minimal attention. Complex circuit construction monitors the battery condition, adjusting the recharge current to suit. When the recharge cycle is complete, to maintain the full capacity, a low output current will continue as required.

**Warning!** Check the condition of the charger and battery prior to each charge. If there is any sign of damage then do not commence charging, seek advice from Draper Tools.

The battery pack is supplied un-charged and must be charged before initial use.

To charge the battery pack (4), it must first be removed from the tool.

Check the mains voltage. Make sure the voltage of the power source is the same as the voltage specified on the rating plate of the charger unit.

- Plug the charger adaptor mains plug into the power source.
- Insert the battery pack (4) into the battery charger (7).
- A full battery charge cycle will take approx. 1 hour.
- Remove the battery pack from the charger and unplug.

### 8.2 BATTERY PACK CHARGE STATUS – FIG.3

The amount of charge remaining in the battery pack is indicated by the display (3) located on the upper handle section.

- The display is made up of three lights; green, orange and red, that illuminate every time the ON/OFF switch is operated.
- The level of charge remaining determines how many of the lights will illuminate; Red being minimal low power, red/orange being half power. All three lights illuminated, indicate full charge.



FIG.1

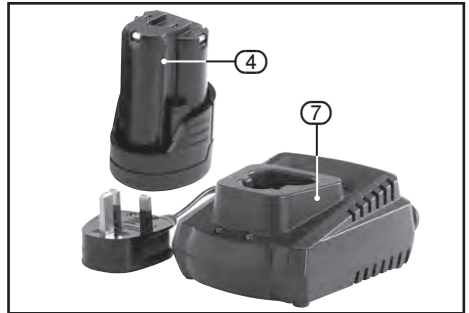

FIG.2

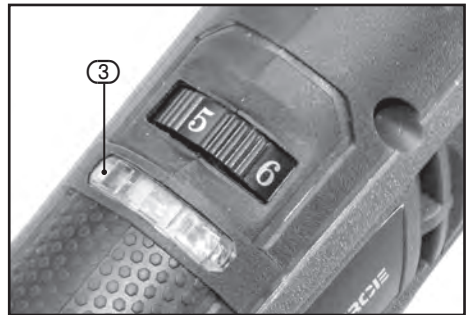

FIG.3

## 9. BASIC MULTI-TOOL OPERATIONS

### 9.1 SWITCHING ON AND OFF – FIG.4

- Slide switch (5) into the 'I' position. This will start the machine. Press switch to the 'O' position – this will stop the machine.

### 9.2 VARIABLE SPEED CONTROL – FIG.5

Using the variable speed dial (2) will enable you to alter the speed of the machine:

- Select the correct speed for the work and type of bit you are using.

### 9.3 FITTING ACCESSORIES – FIG.6

**Note:** Remove the battery from the tool before carrying out adjustment, servicing or maintenance.

When you purchase additional accessories check the safe working speed is compatible with the tool.

- Choose the appropriate size for the bit shank from the five collets provided.
- If the size is not known, insert the bit into the collet.
- The collet (19) which offers a machine fit to the bit is the correct one to use. Do not force the bit into a collet.
- Press spindle locking button (1) to stop the spindle from rotating.
- Using the spanner (21), loosen the collet nut (6).
- Place the collet (19) into the spindle and loosely replace the nut (6).

**Note:** Do not over tighten the collet nut (6).

### 9.4 FITTING ACCESSORIES USING A MANDREL – FIG.7

- With the mandrel (20) in the chuck, remove the screw (20.1) using the plain slot screwdriver (21) (incorporated in the spanner handle tip).
- Leave one fibre washer on the screw, place the cutting/grinding/polishing disc on the screw and fit the second fibre washer, refit to the disc holder spindle. (Do not over tighten).

### 9.5 HOLDING THE TOOL

For jobs such as milling or engraving where precision is required, hold the multi-tool like a pen.

Care should be taken not to fully cover exhaust vents. Covering the vents will cause the machine to overheat and fail.

For heavier work like cutting or grinding hold the multi-tool in the palm of your hand.

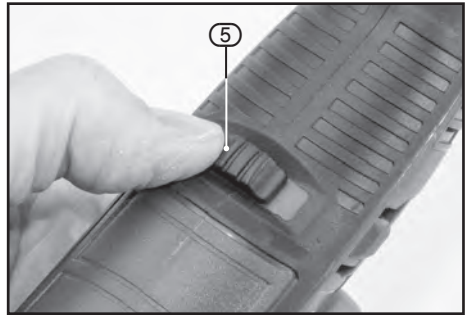

FIG.4



FIG.5

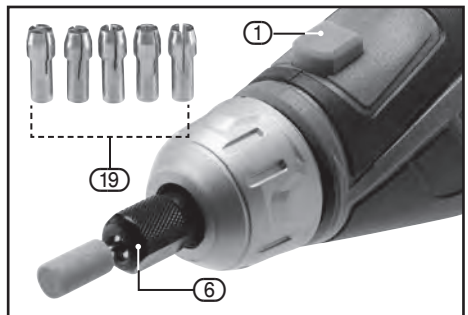

FIG.6

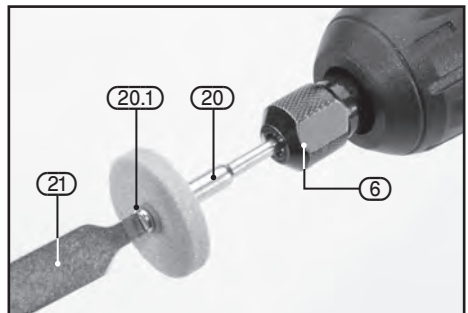

FIG.7

## 9. BASIC MULTI-TOOL OPERATIONS

### 9.6 ATTACHMENTS AND MACHINE SPEEDS

Grinding points and discs (9), (16)	
MATERIAL	SPEED
Stone	1
Steel	5
Aluminium	2
Brass	2
Plastic	1

Polishing discs (17)	
MATERIAL	SPEED
Steel	5
Aluminium	3
Brass	5

Diamond engraving and milling bits (10), (11)	
MATERIAL	SPEED
Stone	6
Steel	3
Aluminium	6
Brass	6
Plastic	1

Brass, steel and bristle brushes (12), (13), (14)	
Material	Speed
Stone	2
Aluminium	2
Brass	2

Cutting disc (18)	
MATERIAL	SPEED
Stone	6
Steel	3
Aluminium	6
Brass	6
Plastic	1

### 9.7 OPTIONAL ACCESSORIES

A full range of accessories are available from Draper Tools.

Please visit our website for details: [www.drapertools.com](http://www.drapertools.com)

# 10. DISPOSAL

---

## 10.1 DISPOSAL

- At the end of the machine's working life, or when it can no longer be repaired, ensure that it is disposed of according to national regulations.
- Contact your local authority for details of collection schemes in your area.

In all circumstances:

- Do not dispose of power tools with domestic waste.
- Do not incinerate.
- Do not dispose of WEEE\* as unsorted municipal waste.



**Li-ion**

\* Waste Electrical & Electronic Equipment.

## 10.2 BATTERY PACK DISPOSAL INFORMATION

### Warning!

- Do not put battery pack in fire or mutilate – cells may burst or release toxic materials.
- Do not short circuit cells, may cause burns.
- The battery pack must be removed from the appliance before it is scrapped.
- The battery pack is to be disposed of safely.
- Do not mutilate batteries, corrosive electrolyte will be released.
- Do not dispose of batteries or cells in a charged condition.

Expired batteries must be recycled/disposed of in accordance with the appropriate regulation or legislation. They should be returned to your local warranty agent/stockist.



# 11. EXPLANATION OF SYMBOLS

## 11.1 EXPLANATION OF SYMBOLS



Read the instruction manual.



Wear face mask and safety glasses.



Wear ear defenders.



Wear protective gloves.



Do not abandon into the environment.



Keep out of the reach of children.



**Warning!**



5,000 – 25,000 Revolutions per minute (R/min).



1.5Ah Lithium-ion battery.



Supplied with 1 × battery.



Net product weight  
(*example shown*).



Do not incinerate or throw onto fire.



For indoor use only.  
Do not expose to rain.



Short-circuit-proof safety isolating transformer.



2A Fuse protective device.



Polarity indication.



Rated voltage.



Class II construction  
(Double insulated).



WEEE –  
Waste Electrical & Electronic Equipment.  
Do not dispose of Waste Electrical & Electronic Equipment in with domestic rubbish.



UK Conformity Assessed.



European conformity.



Continuous A-Weighted Sound Pressure Level  
(*example shown*).

# NOTES

---

# NOTES

---

# CONTACTS

Draper Tools Limited

UK: Hursley Road, Chandler's Ford, Eastleigh,  
Hampshire. SO53 1YF. U.K.

EU: Oude Graaf 8  
6002 NL Weert (NL)

Help Line: (023) 8049 4344

Sales Desk: (023) 8049 4333

Internet: [drapertools.com](http://drapertools.com)

E-mail: [sales@drapertools.com](mailto:sales@drapertools.com)

General Enquiries: (023) 8026 6355

Service/Warranty Repair Agent:

For aftersales servicing or warranty repairs, please contact the  
Draper Tools Help Line for details of an agent in your local area.

## YOUR DRAPER STOCKIST

TACH0921

©Published by Draper Tools Limited.

No part of this publication may be reproduced, stored in a retrieval system or transmitted in any form or by any means, electronic, mechanical photocopying, recording or otherwise without prior permission in writing from Draper Tools Ltd.