

EN

Original Instructions
Version 1

DRAPER[®]

500KG VERTICAL

TRANSMISSION JACK

08556



UK
CA CE

1. Preface

These are the original product instructions. This document is part of the product; retain it for the life of the product, passing it on to subsequent holders. Read this manual in full before attempting to assemble, operate or maintain this product.

This Draper Tools manual describes the purpose of the product and contains all the necessary information to ensure its correct and safe use. Following all the instructions and guidance in this manual will ensure the safety of both the product and the operator and increase the lifespan of the product.

All photographs and drawings within this manual are supplied by Draper Tools to help illustrate correct operation of the product.

Every effort has been made to ensure the information contained in this manual is accurate. However, Draper Tools reserves the right to amend this document without prior warning. Always use the latest version of the product manual.

1.1 Product Reference

User Manual for: Transmission Jack, 500kg

Stock No: 08556

Part No: TJ500B

1.2 Revisions

Version 1: June 2023

First release

As our manuals are continually updated, always ensure that the latest version is used.

Please visit drapertools.com/manuals for the latest version of this manual and the associated parts list, if applicable.

1.3 Understanding the Safety Content of This Manual



WARNING! – Situations or actions that may result in personal injury or death.



CAUTION! – Situations or actions that may result in damage to the product or surroundings.

Important: – Information or instructions of particular importance.

1.4 Copyright © Notice

Copyright © Draper Tools Limited.

Permission is granted to reproduce this manual for personal and educational use **ONLY**. Commercial copying, redistribution, hiring or lending is strictly prohibited.

No part of this manual may be stored in a retrieval system or transmitted in any other form or means without written permission from Draper Tools Limited.

In all cases, this copyright notice must remain intact.

1. Preface	2
1.1 Product Reference	2
1.2 Revisions	2
1.3 Understanding the Safety Content	2
1.4 Copyright © Notice	2
2. Contents	3
3. Product Introduction	4
3.1 Intended Use	4
3.2 Specification	4
4. Health and Safety Information	5
4.1 General Health and Safety Instructions for this Product	5
4.2 Correct Use of the Transmission Jack	5
4.3 Residual Risk	6
5. Identification and Unpacking	7
5.1 Product Overview	7
5.2 What's in the Box?	8
5.3 Packaging	8
6. Assembly Instructions	9
7. Operating Instructions	10
7.1 Preparing the Jack for Use	10
7.2 Operating the Jack	11
8. Maintenance and Troubleshooting	12
8.1 General Maintenance	12
8.2 Checking and Replacing the Oil	12
8.3 Storing the Jack	12
8.4 Troubleshooting	13
9. Spares, Returns and Disposal	14
10. Warranty	14
11. Explanation of Symbols	15

3. Product Introduction

3.1 Intended Use

This jack is designed for supporting transmission systems and differentials within the rated capacities during installation and removal. Any other application beyond the conditions established for use will be considered misuse. Draper Tools accepts no responsibility for improper use of this product.

Important: This product is **NOT** suitable for elevating or supporting vehicles.

Part of our core range, this product is suitable for regular use by enthusiasts and tradespersons alike.



WARNING! This product is not a toy and must be respected.

Read this manual in full before attempting to assemble, operate or maintain the product, and retain it for later use.

3.2 Specification

Stock No.	08556
Part No.	TJ500B
Rated capacity	500kg
Minimum height	112cm
Maximum height	194cm
Base dimensions	80 x 120cm
Saddle type	Fixed
Net weight	23.6kg

Important: Read all the Health and Safety instructions before attempting to operate, maintain or repair this product. Non-compliance with these instructions may result in injury or damage to the user, the product or the load.

4.1 General Health and Safety Instructions for this Product

- Only personnel who have read and understood this manual and are trained in the use of this product and the relevant forces are authorised to operate this device.
- Observe all standard safety precautions and good practices when working in a workshop environment.
- Keep your work environment clear and well-lit, with bystanders at a safe distance.
- Before every use, inspect the jack for broken, cracked, loose or corroded parts.
Important: DO NOT use this product if it is damaged in any way. Contact Draper Tools to discuss repair and replacement options.
- **DO NOT** use this product if you suspect that it has been subjected to abnormal loads or shock and have it inspected by a qualified technician.
- Ensure that the warning labels and safety instructions on the product are visible and legible.
- Use the product only in the manner instructed in this manual and **DO NOT** modify it in any way.
- **ONLY** use spare parts supplied by Draper Tools.
- **DO NOT** use this product if you are tired or under the influence of alcohol, drugs or other medication.
- **ALWAYS** wear eye protection and protective gloves and footwear when assembling or operating the jack.
- Keep loose-fitting clothes, jewellery and long hair tied back to prevent it from snagging during operation.
- The wheels of this product **DO NOT** lock.
 - Ensure that the jack will not roll once positioned for use.
- **ALWAYS** ensure that the load is stable and secure in the cradle before raising, lowering or transporting it.
- Before moving the jack, **ALWAYS** inspect the intended route and ensure that it is clear of obstructions.

- Take care when moving the jack.
 - **ALWAYS** ensure that the load is fully secure before moving the jack.
 - **DO NOT** use the jack on uneven surfaces that may cause it to tip over.
 - **ALWAYS** bring the load to its lowest possible position before transportation.
- **NEVER** leave the jack unattended when it is in use or under load.
- When not in use, ensure that the ram is in its lowest position and the release valve is fully closed.
- This jack does not emit noise that exceeds a level of 70 dB(A) during operation.



WARNING! If the jack tips or leans while under load, move immediately to a safe distance. DO NOT attempt to steady or hold the jack.

4.2 Correct Use of the Transmission Jack



CAUTION! This product is designed to support loads for short periods ONLY. DO NOT use this product to support a load for longer than 30 minutes at a time.

- **ALWAYS** bleed the jack before use.
- **ONLY** operate the jack on solid, level and horizontal surfaces.
 - A concrete surface is recommended, where possible.
- **WARNING! NEVER use the jack on any surface that is slippery or may sink or rock.**
- **NEVER** attempt to lift or support any load that exceeds the rated capacity of the jack.
- **NEVER** attempt to lift any load higher than the maximum safe height of the jack.
- **DO NOT** use excessive force when opening and closing the release valve as this may damage the piston.
- When attaching a load to the jack, **ALWAYS** use the manufacturer's recommended contact points.
- Ensure that the contact points are not dirty, greasy or corroded.
- **ALWAYS** ensure that the load is fully detached from its surroundings before moving it.
- **NEVER** allow anyone to position themselves or other obstructions beneath the load during raising and lowering or below any load supported only by the jack.

4. Health and Safety Information

- **DO NOT** stand or climb on the jack.
- To prevent overloading, the jack is fitted with an overload valve set at the factory.
Important: The overload valve **MUST NOT** be adjusted under any circumstances. If the safe capacity of the jack is exceeded, the valve will prevent the lifting operation.
- Take **all** precautions to prevent movement of the load during raising and lowering.
 - Be aware that external forces may cause the load to rock.
- Stay alert to external interference that may cause the raised load to rock during preparation and operation.
 - Should any dangerous conditions occur, cease all operation until these conditions have been rectified.
- Stay alert to the possibility of the load slipping from the cradle and remain observant at all times.
- **ALWAYS** ensure that the vehicle is raised to the correct height before attempting to move the jack underneath it.
- **ALWAYS** ensure that the vehicle is level and adequately supported before removing the transmission or differentials.
- Take any necessary precautions to prevent the vehicle from sliding, including chocking the wheels (Rubber Wheel Chocks, Stock No. 54500, for example).
- **DO NOT** move the jack further than is absolutely necessary while under load.
 - **ALWAYS** ensure that the route from the location of engine to its destination is clear of obstructions and is as short as possible.
- If the jack vibrates excessively during use, have the product serviced by a qualified and authorised technician.

 **WARNING! NEVER work under an unsupported vehicle.**

4.3 Residual Risk

The safety instructions in this manual cannot account for all possible conditions and situations that may occur. Exercise common sense and caution when using this product and protect against any additional conceivable risks.

5.1 Product Overview



(1) Base frame

(2) Castors

(3) Cradle

(4) Hydraulic unit

(5) Oil filler cap

(6) Pump pedal

(7) Ram

(8) Release valve handle

(9) Transport handles

5. Identification and Unpacking

5.2 What's in the Box?

Carefully remove the product from the packaging and examine it for any signs of damage that may have occurred during shipment.

Before assembling the product, lay the contents out and check them against the parts shown below. If any part is damaged or missing, do not attempt to use the product. Please contact the Draper Helpline; contact details can be found at the back of this manual.

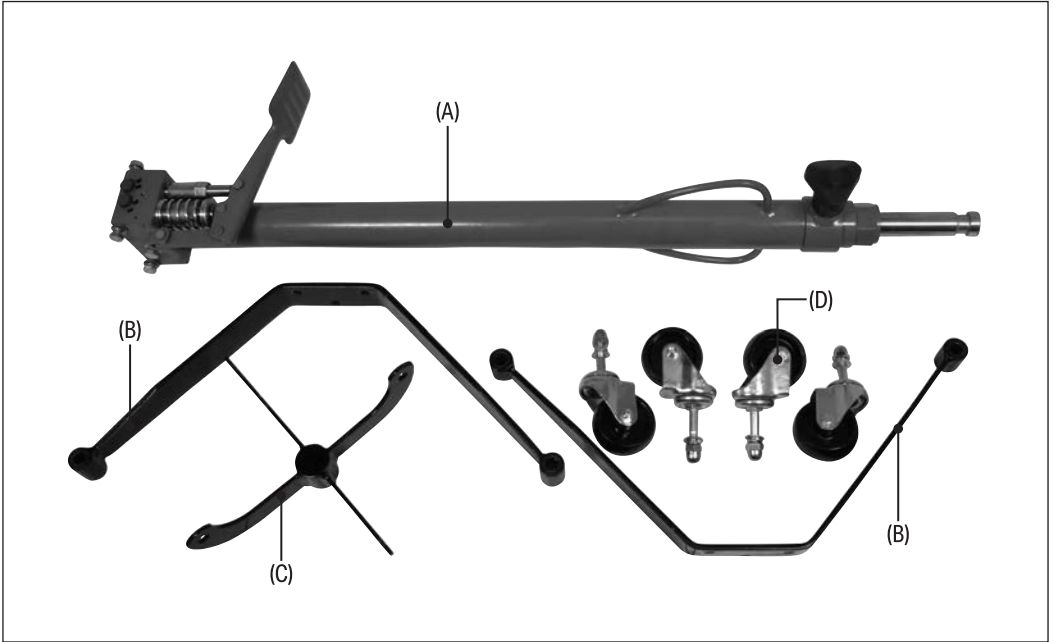

- (A) 1 x Hydraulic unit
- (B) 2 x Base frame brackets
- (C) 1 x Cradle
- (D) 4 x Castors

5.3 Packaging

Keep the product packaging for the duration of the warranty period in case the product needs to be returned for repair.



WARNING! Keep packaging materials out of reach of children. Dispose of packaging correctly and responsibly and in accordance with local regulations.

Please visit drapertools.com for our full range of accessories and consumables.

6. Assembly Instructions

EN

Important: Read and understand all the safety instructions listed in this manual before attempting to assemble this product. Some parts may be assembled before shipment.

1. Remove the three hex bolts, spring washers and flat washers from one side of the base of the hydraulic unit (A).
2. Align a base frame bracket (B) with the base of the hydraulic unit and use the hex bolts, spring washers and flat washers to secure them in place.

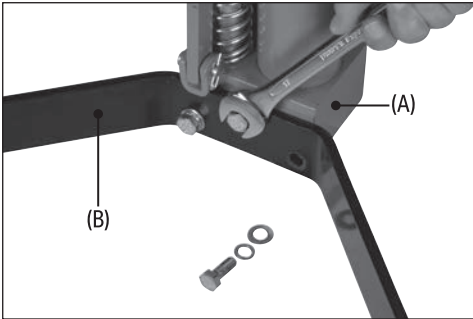

Fig. 1

3. Remove the dome nuts, spring washers and flat washers from two of the castors (D).
4. Pass a castor bolt up through each base frame bracket socket and secure it in place using the flat washers, spring washers and dome nuts.

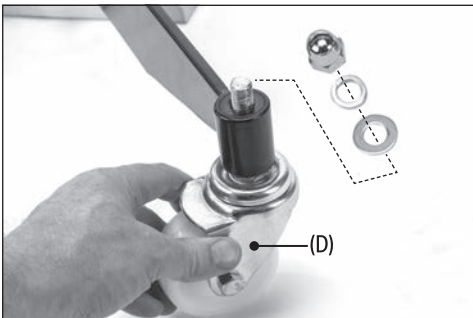

Fig. 2

5. Repeat these steps for the other frame bracket.
6. Place the cradle (C) socket over the ram (7) head.

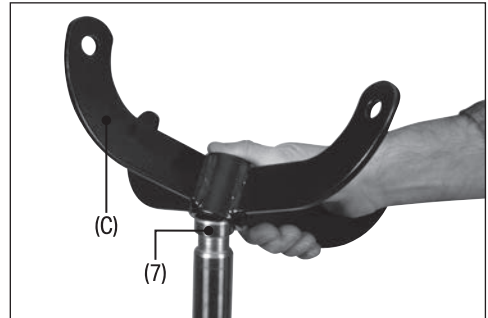

Fig. 3

7. Operating Instructions

Important: Before lifting any load, read and understand all the safety instructions listed in this manual. **ALWAYS** test the jack thoroughly, bleed the piston and ensure that all bolts and attachments are securely fastened before use.

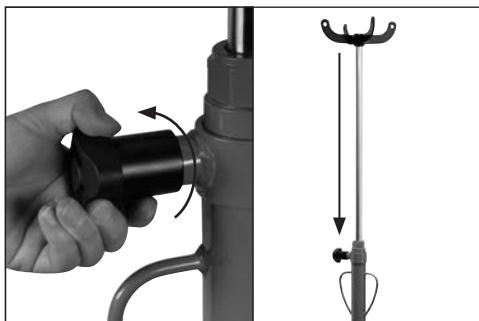

Fig. 4
Rotating the release valve handle anticlockwise opens the valve and lowers the ram.

CAUTION! This product is for lifting transmission systems and differentials **ONLY**. **DO NOT** use this product to suspend equipment for prolonged periods.



Fig. 5
Rotating the release valve handle clockwise closes the valve.

7.1 Preparing the Jack for Use

Prepare the jack correctly before **EVERY** use:

1. Check the jack for bent, broken, cracked or loose parts, and oil leaks and ensure that the castors (2) rotate freely.



WARNING! DO NOT use the product if defects are present. If it is suspected that the jack has been subjected to abnormal loads or has suffered any knocks, withdraw it from service until the product has been repaired.

2. Check the piston oil level; see 8.2 Checking and Replacing the Oil.
3. Bleed the jack piston:
 - a. Rotate the release valve handle (8) anticlockwise to open the valve.
 - b. Allow the ram (7) to drop slowly to its lowest position, then open the release valve a little further.
 - c. Apply downward force to the ram while rapidly operating the pump pedal (6) at least ten times using the full stroke range to lubricate the ram and expel any accumulated air.
 - d. Loosen the oil filler cap (5) and allow any additional air to escape.
 - e. Rotate the release valve handle clockwise until strong resistance is felt to close the valve.

4. Test the jack:
 - a. With the release valve fully closed, operate the pump pedal to raise the ram to its highest position.
 - b. Observe the ram to check that it does not drop.
 5. If the ram begins to drop without intervention:
 - a. Open the release valve and allow the ram to drop to its lowest position.
 - b. Operate the pump pedal another ten times.
 - c. Manually raise the ram and force it downwards as quickly as possible several times.
- WARNING!** When manually lifting the ram, keep in mind that it will not be held in place by the piston when raised. Ensure that the jack does not roll on its castors when the ram is manually lowered.
- d. Close the release valve.
6. Test the jack again by raising the ram and ensuring that it does not drop without intervention.
 7. Repeat this process several times. If the issue is not resolved after several attempts, contact Draper Tools for assistance.

7. Operating Instructions

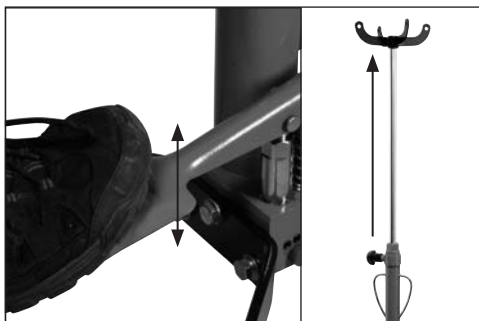

Fig. 6

Operating the pump pedal raises the ram if the release valve is closed.

7.2 Operating the Jack

1. Correctly prepare the jack for use; see **7.1 Preparing the Jack for Use**.
2. Raise the vehicle to an appropriate height and secure it on suitable supports (not supplied).
3. Gripping the transport handles (9), move the jack into position beneath the vehicle.
4. Ensure that the release valve is closed (Fig. 1) and operate the pump pedal (6) to extend the ram until the cradle (3) contacts the transmission system.
5. Ensure that the load is positioned centrally against the brackets of the cradle, then carefully pump up the ram a little further to transfer the weight of the load from the vehicle to the jack.
Important: Grip the transport handles during lifting and lowering to keep the jack steady.
6. Detach the transmission system from the vehicle, ensuring that movement of the load is not obstructed in any way.
7. Check that the cradle is securely and comfortably holding the load and does not show signs of stress.
8. Secure the load tightly with a chain (not supplied) through the holes in the cradle brackets.
9. Ensure that no one is present beneath the load and that the load can be lowered without obstruction, then slowly open the release valve just enough to allow the ram to drop to its lowest position.
Important: The rate at which the load will drop is dependent on its weight.
10. Check the cradle again for signs of stress or poor seating of the load.
11. With the ram in its lowest position, manoeuvre the jack to a suitable workspace to operate on the load.
12. When work is complete, perform this procedure in reverse to install the transmission system back into the vehicle.

8. Maintenance and Troubleshooting

Important: Maintenance and repair of the jack must only be performed by qualified personnel with sufficient knowledge of the hydraulics systems used in these devices. All maintenance should be performed in accordance with these instructions.

Important: ALWAYS drain the jack of oil before returning it to Draper Tools for repair.



WARNING! DO NOT attempt to perform any maintenance on the jack while it is under load. Safely lower and remove any load from the jack and drop the ram to its lowest position before proceeding.

8.1 General Maintenance

- Keep the jack clean and regularly lubricate all moving parts.
 - Dust and debris may cause components to become clogged or jammed, and the product may not perform at its best.
- Protect the jack and its components from adverse environmental and weather conditions, both during use and when stored.
 - The components may rust if exposed to water or damp air for prolonged periods.
- Before each use, check the jack for signs of damage or disrepair.



CAUTION! NEVER attempt to open the hydraulic unit as this may irrevocably damage the product.

8.2 Checking and Replacing the Oil

To extend the working life of the product, keep the oil at an appropriate level and replace it after periods of prolonged intensive use or at least once every year.



CAUTION! Use AW 22 hydraulic oil. Never use brake or engine oil. DO NOT pump the piston while topping up the oil.



WARNING! Oil spillage may cause the operating surface to become slippery. Do not operate the jack on oily surfaces.

1. Place the jack on a level, horizontal surface.
2. Turn the release valve handle (8) anticlockwise to open the release valve and fully lower the ram (7).
3. Carefully unscrew and remove the oil filler cap (5).
4. If the oil must be drained, with assistance, tip the jack and allow the oil to completely drain from the piston into a suitable container.
5. Tip the jack upright and carefully pour oil into the opening until it is completely full.
6. Replace the oil filler cap and wipe up any spillages.
7. Ensure that all fixings are tight, then bleed and test the jack; see **7.1 Preparing the Jack for Use**.

Important: Dispose of oil according to local regulations.

8.3 Storing the Jack

When the jack is not in use:

- Remove any load installed on the jack.
- Move the ram to its lowest position and close the release valve.
- Store the jack in a clean and dry location, out of reach of children.
- Keep the jack covered while it is stored.

8.4 Troubleshooting

Problem	Possible Cause	Remedy
The ram does not raise when the pump pedal is operated.	The release valve is not fully closed.	Rotate the release valve handle clockwise until strong resistance is felt. Bleed the piston if necessary.
	The maximum load has been exceeded.	Use an appropriately rated jack or reduce the weight of the load. DO NOT adjust the overload valve.
	The piston system is corroded.	DO NOT use the jack. Contact Draper Tools to discuss repair or replacement options.
	The piston oil level is too low.	Top up the oil; see section 8.2.
The ram drops once lifted or will not lift to its full height.	The release valve is not fully closed.	Rotate the release valve handle clockwise until strong resistance is felt. Bleed the piston if necessary.
	The hydraulics mechanism is damaged.	DO NOT use the jack. Contact Draper Tools to discuss repair or replacement options.
	There is air in the hydraulic system.	Bleed the piston; see 7.1.
The ram does not extend to its full height.	The oil level is low.	Top up the oil; see section 8.2.
The ram extends at an angle.	The base frame brackets are not square.	Lower the ram and check the fixings of the base frame brackets.
The ram lowers slowly or not at all when the release valve is opened.	The oil reservoir is overfilled.	Follow the steps in section 8.2, adding less oil than previously.
	The piston ram is binding.	Follow the steps in 7.1 to lubricate the hydraulic mechanism.
	The ram has been overextended and cannot be withdrawn.	Have the ram replaced; contact Draper Tools for support.
The pump pedal is stiff or the ram raises slowly.	The piston system is not appropriately lubricated.	Follow the steps in section 7.1.
Oil is leaking from the oil filler cap.	The oil level is too high.	Follow the steps in 8.2 to drain any excess oil.

9. Spares, Returns and Disposal

For spare parts, servicing, and repair and replacement options, please contact the Draper Tools Product Helpline for details of your nearest authorised agent.

Draper Tools will endeavour to hold any spare parts, if applicable, for seven years from the date that it sells the final matching stock item.

Any servicing or repairs carried out by unauthorised personnel or installation of spare parts not supplied by Draper Tools will invalidate your warranty.

Important: For safety, **ALWAYS** drain and clean the product of oil before returning it to Draper Tools or its authorised agent. Store these materials in suitable containers and dispose of them in accordance with local regulations. Draper Tools and its agents cannot be responsible for the disposal of these substances.

At the end of its working life, dispose of the product responsibly and in line with local regulations. Recycle where possible.

Dispose of oil separately and in accordance with local regulations; **DO NOT** abandon it in the environment.



10. Warranty

Draper Tools products are carefully tested and inspected before shipment and are guaranteed to be free from defective materials and workmanship.

Should the tool develop a fault, return the complete tool to your nearest distributor or contact Draper Tools directly. Contact information can be found at the back of this manual.

Proof of purchase must be provided.

If, upon inspection, it is found that the fault occurring is due to defective materials or workmanship, repairs will be carried out free of charge. This warranty period covers parts and labour for 12 months from the date of purchase. Where tools have been hired out, the warranty period covers 90 days from the date of purchase.

This warranty does not apply to any consumable parts, batteries or normal wear and tear, nor does it cover any damage caused by misuse, careless or unsafe handling, alterations, accidents, or repairs attempted or made by any personnel other than the authorised Draper Tools repair agent.

In all cases, to make a claim for faulty workmanship or materials within the standard warranty period, please contact or return the product to the place of purchase. Proof of purchase may be required.

If the place of purchase is no longer trading or if you experience any difficulties with your warranty, please contact Customer Services with the product details and your proof of purchase. Contact details can be found at the back of this manual.

If the tool is not covered by the terms of this warranty, repairs and carriage charges will be quoted and charged accordingly.

This warranty supersedes any other guarantees expressed or implied and variations of its terms are not authorised.

Your Draper Tools guarantee is not effective until you can produce, upon request, a dated receipt or invoice to verify your purchase within the guarantee period.

Please note that this warranty is an additional benefit and does not affect your statutory rights.

Draper Tools Limited

11. Explanation of Symbols



Read the instruction manual



Warning!



Do not abandon in the environment



Minimum lift height



Maximum lift height



Net weight



European conformity



UK Conformity Assessed

Contact Details

Draper Tools

Draper Tools Limited
Hursley Road
Chandler's Ford
Eastleigh
Hampshire
SO53 1YF
UK

Website: drapertools.com

Email: sales@drapertools.com

Product Helpline: +44 (0) 23 8049 4344

Telephone Sales Desk: +44 (0) 23 8049 4333

General Enquiries: +44 (0) 23 8026 6355

General Fax: +44 (0) 23 8026 0784

Delta International

Delta International BV
Oude Graaf 8
6002 NL
Weert
Netherlands

Please contact the Draper Tools Product Helpline for repair and servicing enquiries.