

EN

Original Instructions
Version 2 – February 2024

DRAPER[®]

INFRARED
**DIESEL SPACE
HEATER**

17111



**UK
CA** **CE**

1. Preface

These are the original product instructions. This document is part of the product; retain it for the life of the product, passing it on to subsequent holders. Read this manual in full before attempting to assemble, operate, or maintain this product.

This Draper Tools manual describes the purpose of the product and contains all the necessary information to ensure its correct and safe use. Following all the instructions and guidance in this manual will ensure the safety of both the product and the operator and increase the lifespan of the product.

All photographs and drawings within this manual are supplied by Draper Tools to help illustrate correct operation of the product.

Every effort has been made to ensure the information contained in this manual is accurate. However, Draper Tools reserves the right to amend this document without prior warning. Always use the latest version of the product manual.

1.1 Product Reference

User Manual for: Infra-Red Diesel Space Heater

Stock No: 17111

Part No: DSH-IR-B

1.2 Revisions

Version 1: May 2016
First release

Version 2: February 2024
Layout update

As our manuals are continually updated, always ensure that the latest version is used.

For the latest version of this manual and the associated parts list, if applicable, please visit

drapertools.com/manuals

1.3 Understanding the Safety Content of This Manual



WARNING! – Situations or actions that may result in personal injury or death.



CAUTION! – Situations or actions that may result in damage to the product or surroundings.

Important: – Information or instructions of particular importance.

1.4 Copyright © Notice

Copyright © Draper Tools Limited.

Permission is granted to reproduce this manual for personal and educational use **ONLY**. Commercial copying, redistribution, hiring, or lending is strictly prohibited.

No part of this manual may be stored in a retrieval system or transmitted in any other form or means without written permission from Draper Tools Limited.

In all cases, this copyright notice must remain intact.

1. Preface	2
1.1 Product Reference	2
1.2 Revisions	2
1.3 Understanding the Safety Content of This Manual	2
1.4 Copyright © Notice	2
2. Contents	3
3. Product Introduction	4
3.1 Scope	4
3.2 Specification	4
4. Health and Safety Information	5-7
4.1 General Health and Safety Precautions	5
4.2 Additional Safety information for this Heater	5
4.3 Electrical Safety	6
4.4 Health and Safety Information for the Use of Diesel and Kerosene Fuel	6
4.5 Service	7
4.6 Connection To the Power Supply	7
4.7 Residual Risk	7
5. Identification and Unpacking	8-9
5.1 Product Overview	8
5.2 Packaging	9
6. Preparing the Heater	9
6.1 Fuels	9
6.2 Fuelling Your Heater	9
6.3 Ventilation	9
7. Operating Instructions	10
7.1 Starting The Heater	10
7.2 To Turn the Heater Off	10
7.3 To Restart Heater	10
7.4 Fuel System	10
7.5 The Safety System	10
7.6 Draining the Fuel Tank	10
8. Maintenance and Troubleshooting	11
8.1 Cleaning The Filter	11
8.2 Fan/Nozzle/Ignition Plug/Photocell Care & Servicing	11
8.3 Storing the Heater	11
8.4 Troubleshooting	11
9. Spares, Returns and Disposal	12
10. Warranty	13
11. Explanation of Symbols	13

3. Product Introduction

3.1 Intended Use

This infrared heater is designed to be used in open and well ventilated areas by means of Diesel or Kerosene fuel. Supplied with automatic ignition and fitted with a photocell safety device with heat protection.

Read this manual in full before attempting to assemble, operate or maintain the product, and retain it for later use.

Any other application beyond the conditions established for use will be considered misuse. Draper Tools accepts no responsibility for improper use of this product.

3.2 Specification

Stock No.	17111
Part No.	DSH-IR-B
Motor:	
Rated voltage	230V
Rated frequency	50Hz
Rated input	94W
Heat output	17kW/60,000BTU
Fuel	Diesel/Kerosene
Fuel tank capacity	12L
Diesel consumption	1.39L/hr
Operation time (with full tank)	Approx. 9hrs
Net weight	13.8kg
Dimensions	560 x 330 x 560mm

4. Health and Safety Information

4.1 General Health and Safety Precautions

 **WARNING!** Read all safety warnings and all instructions. Failure to follow the warnings and instructions may result in electric shock, fire and/or serious injury. Save all warnings and instructions for future reference.

- This appliance is not suitable for use by children and may not be used by persons with reduced physical, sensory or mental capabilities, or lack of experience or knowledge unless they are supervised or trained in the correct use of the device and fully understand the hazards involved.

- **DO NOT** allow children to play with the appliance.
- Cleaning and maintenance **MUST** be carried out by or under the supervision of experienced and knowledgeable persons.

- Observe all standard safety precautions and good practices when working with electrical equipment.
- Keep your work environment clear and well-lit, with bystanders at a safe distance.
- Inspect the product before every use for cracked, corroded or broken parts and any leakages.

 **WARNING! DO NOT** use this product if it is damaged or leaking in any way. Contact Draper Tools for repair and replacement options.

- Use the product only for its intended purpose and as instructed in this manual.
- **DO NOT** attempt to disassemble or modify this product in any way.
- If the heater is not working properly. Switch off and disconnect the heater and move to a well-ventilated area **IMMEDIATELY**. Have the heater checked for correct operation by a qualified engineer before next use.
- If the supply cord is damaged, it must be replaced by Draper Tools or their authorised representative in order to avoid a hazard.
- **NEVER** abuse the power cord:
 - Unwind the power cord fully before connecting it to the power supply.
 - **NEVER** remove the plug from the power supply by pulling on the cord.
 - **DO NOT** move the product using the cord or plug.
 - Keep the power cord away from sources of heat, liquids, sharp edges and moving parts.

4.2 Additional Safety information for this Heater

 **WARNING! Improper use of this heater may result in serious injury or death from burns, fire, explosions, electrical shock and carbon monoxide poisoning.**

 **WARNING!** Only use this heater in well ventilated areas and ensure continuous ventilation is provided.

- **NOT** suitable for domestic use.
- This heater is intended for use in commercial/ industrial buildings where adequate ventilation is provided. **DO NOT** use this heater in small habitable areas that are occupied by individuals that are not capable of leaving the room on their own, unless constant supervision is provided.
- **DO NOT** use the heater in closed rooms, living areas, basements or below ground level.
- **DO NOT** use the heater in dusty environments.
- **DO NOT** expose this product to temperatures greater than 60°C.
- Position the heater on a firm, level, heat resistant and non combustible surface during use and ensure that it is correctly and safely positioned.
- The heater must **ONLY** be used in its normal operating position.
- An outside air opening of at least 3 square foot (2,800 sq cm) must be provided for every 30,000Kcal/hr of the heater rating.
- **ALWAYS** observe the correct clearances between the heater and surrounding objects:
 - **Outlet:** 2.5m (8ft)
 - **Sides, top and rear:** 1.25m (4ft)
- **DO NOT** position the heater near to curtains or other combustible materials that may move and come into contact with the heater.
- **DO NOT** position this heater in the vicinity of combustible materials, in explosive environments or in the presence of flammable or combustible gases and vapours.
- **DO NOT** position this heater below or pointing towards a power socket or outlet.
- **DO NOT** obstruct the air inlet or air outlet of the heater and **DO NOT** use duct work in front or at the rear of the heater.
- Ensure that the power switch is in the “off” (O) position before connecting the heater to the power supply.

- **ALWAYS** check that the heater is positioned safely before turning it on.
- **NEVER** leave the heater unattended while it is on under any circumstances.
- **NEVER** cover any part of the heater as this may cause the heater to overheat or the covering item to ignite or burn.
- **NEVER** insert foreign objects through the heat plate or other openings in the heater body.
- **NEVER** place objects on the engine while it is in use and keep all air vents clear of dust, dirt and other obstructions.



WARNING! Risk of shock!

- **DO NOT** allow the heater to come into contact with water or any other liquid.
- **DO NOT** expose the heater to water spray, rain, dripping water or wind.
- **DO NOT** use this heater in the vicinity of a bath, shower, swimming pool or other body of water.
- **DO NOT** touch the heater with wet hands.



WARNING! Some parts of the product become extremely hot during use and may cause burns.

- **DO NOT** touch any metal part of the heater other than the handle during or immediately after use.
- **DO NOT** touch or otherwise interfere with the fuel tank while the heater is in use or is still hot.
- **ALWAYS** switch off the heater, disconnect it from the power supply and allow it to cool for at least 20 minutes before attempting to move or reposition it.
- Particular attention **MUST** be given when children and vulnerable people are present.

4.3 Electrical Safety

- **ONLY** use this product with a power supply that matches the rated voltage of the heater.
 - **NEVER** use this heater with a multi-socket or plug adaptor.
 - **NEVER** plug more than one heater into the same power outlet.
 - **NEVER** allow the power cord to come into contact with other heated objects or direct the heater at the power cord or supply.
 - **ALWAYS** unplug when not in use.
- Avoid body contact with earthed or grounded surfaces, such as pipes, radiators, ranges and refrigerators.

- **DO NOT** use this heater with a programmer, timer, separate remote-control system or any other device that switches the heater on automatically as it may be covered or positioned incorrectly when activated and pose a fire risk.

4.4 Health and Safety Information for the Use of Diesel and Kerosene Fuel

Important: ALWAYS read and understand the fuel product label before use.

- **ONLY** use clean Diesel or Kerosene fuel with this heater.



WARNING! DO NOT use fuels such as petrol, benzene, paint thinners or other oil compounds in this heater under any circumstances.

- **NEVER** smoke in the vicinity of the machine, especially during refuelling.
- **NEVER** refuel the heater while it is switched on or is still hot.
- **ALWAYS** wear suitable protective gloves and other clothing during refuelling.
- **NEVER** transport the heater with fuel in the fuel tank; drain and store or dispose of all fuel responsibly before transporting the heater.
- **NEVER** start the engine if you can smell fuel vapour in the air.
 - If fuel vapour is present, wait for it to dissipate or move to a new location.
- The engine and fuel get hot during use.
 - **DO NOT** touch the engine during or immediately after use and allow it to cool before refuelling.
- **NEVER** remove the fuel cap while the engine is running or immediately after use.
 - Take care when opening the fuel cap after use as hot vapour may be released from the opening.
- Store all fuels in a cool, clean and dry environment, away from direct sunlight and out of reach of children.
 - Adhere to all local guidance relating to the correct storage of fuel.



WARNING! Diesel is a carcinogenic substance, and Kerosene is known to have health implications if handled improperly. Exercise extreme caution when transporting and storing fuel and during refuelling. Clean up spillages IMMEDIATELY and dispose of fuel responsibly and in accordance with local regulations.



WARNING! Burning Diesel emits toxic carbon monoxide: a colourless and odourless gas. Breathing exhaust fumes can cause loss of consciousness, permanent respiratory damage and eventually death. ONLY operate this machine in a well-ventilated environment. NEVER use this heater in living or sleeping areas.

4.5 Service

Have your heater serviced by a qualified repair person using only identical replacement parts. This will ensure that the safety of the heater is maintained.

4.6 Connection To the Power Supply



WARNING! Risk of electric shock. DO NOT open this product.

- This appliance is supplied with an approved plug and cord for your safety.
- If the power supply cord is damaged, it must be replaced by Draper Tools, an authorised service agent or similarly qualified personnel in order to avoid a hazard.
- The damaged or incomplete plug, when cut from the cable, must be disabled to prevent connection to a live electrical outlet.
- This product is Class I* and is designed for connection **ONLY** to a power supply matching that detailed on the rating label and compatible with the plug fitted. The value of the fuse fitted is marked on the pin face of the plug. Should the fuse need replacing, ensure the substitute is of the correct rating, approved to BS 1363/A and ASTA or BS Kite marked. This should only be performed by suitably qualified personnel.
- If an extension lead is required, use an approved and compatible lead rated for this appliance. Follow all the instructions supplied with the extension lead.
- If operating the heater outdoors use an extension cord suitable and rated for outdoors use. It is also recommended that a residual current device (RCD) is used.

***Earthed:** This product requires an earth connection to protect against electric shock from accessible conductive parts in the event of a failure of the basic insulation.

4.7 Residual Risk

The safety instructions in this manual cannot account for all possible conditions and situations that may occur. Exercise common sense and caution when using this product and protect against any additional conceivable risks.

5.1 Product Overview

Carefully remove the product from the packaging and examine it for any signs of damage that may have occurred during shipment. If any part is damaged or missing, do not attempt to use the product. Please contact the Draper Helpline; contact details can be found at the back of this manual.

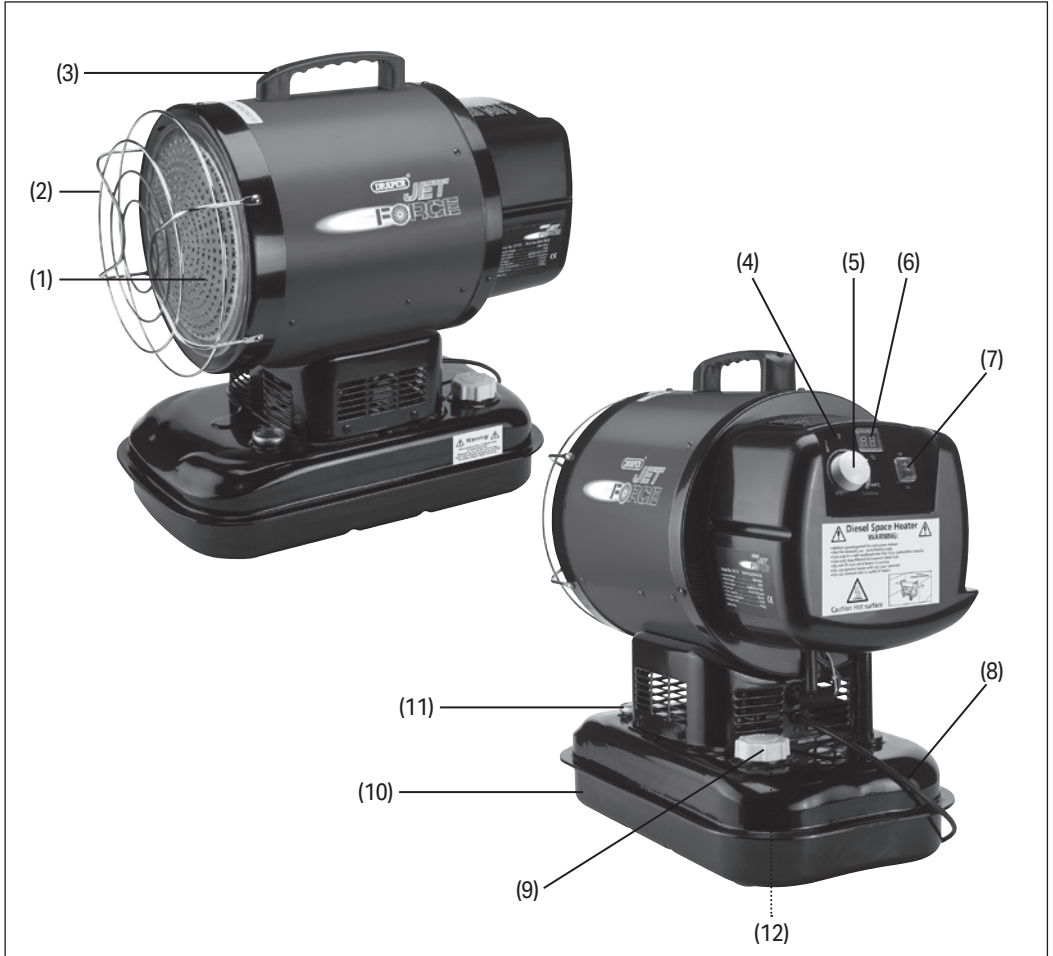

- (1) Infra-red panel
- (2) Grill
- (3) Carry handle
- (4) Lamp
- (5) Thermostat control
- (6) Temperature Window

- (7) Power switch
- (8) Power cable
- (9) Fuel cap
- (10) Fuel tank
- (11) Fuel gauge
- (12) Fuel filter (under fuel cap)

5.2 Packaging

Keep the product packaging for the duration of the warranty period in case the product needs to be returned for repair.



WARNING! Keep packaging materials out of reach of children. Dispose of packaging correctly and responsibly and in accordance with local regulations.

Please visit drapertools.com for our full range of accessories and consumables.

6. Preparing the Heater

Important: Before preparing or adjusting this product, read and understand all the safety instructions listed in this manual.

6.1 Fuels

- Use only standard clean Diesel or Kerosene heater oil according to EN 267.
- **IMPORTANT:** Be sure fuel tank is clean. Foreign matter such as rust, dirt, or water will cause the ignition control assembly to shut down the heater. Foreign matter may also require the heater's fuel system to be frequently cleaned.
- **NOTE:** Diesel or Kerosene should only be stored in a black container that is clearly marked Diesel or Kerosene. Never store Diesel or Kerosene in a red container. Red is associated with petrol.
- **NEVER** store Diesel or Kerosene in the living space. Diesel or Kerosene should be stored in a well-ventilated area outside the living area.
- **NEVER** use old Diesel or Kerosene as it will deteriorates over time and not burn properly in this heater.

6.2 Fuelling Your Heater

- Always fill the heater fuel tank outdoors.
- Do not overfill your heater and ensure the heater is level.



WARNING! Do not fill the fuel tank while the heater is running.

- **DO NOT use or fill the heater without the fuel filter (12) fitted.** The filter will prevent contaminants getting into the tank and clogging the nozzle.

6.3 Ventilation

- **CAUTION!** Risk of indoor air pollution. **DANGER OF DEATH.** Use heater only in well ventilated areas.
- Provide a fresh air opening of at least three square feet (2,800 sq. cm) for each 30,000 kcal/Hr. rating. Provide extra fresh air if more heaters are being used.
- Example: A heater requires one of the following:
 - A two-car garage door raised six inches (15.24 cm).
 - A single-car garage door raised nine inches (22.86 cm).
 - Two, thirty inch (76.20 cm) windows raised fifteen inches (38.1 cm).



WARNING! Never try to use the heater for the purpose of heating residential rooms.

7.1 Starting The Heater

 **WARNING:** Ensure the heater is stood on a **NON-COMBUSTIBLE SURFACE!**

1. Unscrew the fuel cap (9) and fill with appropriate fuel. Refit the cap.
- **DO NOT use or fill the heater without the fuel filter (12) fitted.**
2. Plug into the mains supply.
 - Extension Cable Requirements if used:
 - 6 to 10 feet (1.8 to 3 metres) long, use 1.0mm gauge cable.
 - 11 to 100 feet (3.4 to 30.53 metres) long, use 1.3mm gauge cable.
 - 101 to 200 feet (30.8 to 61 metres) long, use 1.6mm gauge cable.
3. Turn the thermostat control (5) to the desired setting and press the power switch (7) to the **"ON"** position. The Power indicator lamp (4) will light up and the heater will start.
- If the heater does not start, the thermostat setting may be too low. Turn to a higher position. If the heater still does not start switch it off and back on.

7.2 To Turn the Heater Off

1. Turn the power switch to "OFF" and allow the heater fan to cool the unit. Once the cooling fan has stopped unplug the heater.

 **WARNING!** Do not unplug power cord until the fan has stopped as the combustion chamber **MUST** be cooled.

7.3 To Restart Heater

1. Wait 10 seconds after stopping the heater.
2. Repeat steps under, **Section 7.1 Starting the Heater.**

7.4 Fuel System

- This heater is equipped with an electric pump that is connected to the fuel intake, and then through a nozzle in the burner head. This fuel is then sprayed into the combustion chamber in a fine mist. The electronic ignitor sends voltage to a specially designed spark plug. The spark plug ignites the fuel mixture described.
- The motor turns a fan that forces air into and around the combustion chamber, which warms the heater plate, emitting infra-red heat.

7.5 The Safety System

- **Temperature Limit Control:** This heater is equipped with a temperature limit control designed to turn the heater off should the internal temperature rise to an unsafe level. If this device activates and turns your heater off, it may require servicing. Once the temperature falls below the re-set temperature, you will be able to start your heater.
- **Electrical System Protection:** This heater's electrical system is protected by a fuse mounted to the PCB Assembly that protects it and other electrical components from damage. If your heater fails to operate, have this fuse checked first and replace as needed.
- **Flame-Out Sensor:** Utilises a photocell to monitor the flame in the burner chamber during normal operation. It will cause the heater to shut off should the burner flame extinguish.
- **Tip-over sensor:** If the unit is tipped or pushed over during use, the unit will shut down immediately and **DO NOT** re-start until it is totally cooled. Always ensure that the heater is on a stable, non-combustible surface and away from any risk that it could be tipped or pushed over.

7.6 Draining the Fuel Tank

- Place a suitable size container under the heater - remove the fuel cap (9) and empty out the fuel.
- If any debris is noted in the old fuel, add 1 or 2 litres of clean fuel into the tank, wash around and drain again. This will prevent excess debris from clogging the filter during future use.
- Replace fuel cap. Properly dispose of old and dirty fuel in line with local disposal regulations.
- **DO NOT** dispose of old fuel into a main drain - this is illegal.

WARNING: Do not carry out any maintenance or servicing when the heater is hot, fan is still running, or the power supply is connected.

Important: it is recommended that your heater is serviced at least once a year by a qualified repair person using only identical replacement parts.

This will ensure that the safety of the heater is maintained. For aftersales servicing or warranty repairs enquires, contact the Draper Tools Helpline for assistance – contact details can be found on the back of this manual.

8.1 Cleaning The Filter

- Clean the filter (12) by rinsing out with diesel or kerosene at least twice a year or straight away if any contamination is noted when filling the tank. **ALWAYS** replace after cleaning and **DO NOT** operate without the filter fitted.

8.4 Troubleshooting

Error codes will appear in the temperature window (6) if any issues occur with the operation of the heater.

Error code	Error type	Possible cause	Remedy
E0	Power Supply Switch Error	Heater switch in 'ON' position when plugged in.	Switch 'OFF' and unplug. Then plug in before switching to the 'ON' position.
E1	Photocell error	No Fuel in tank.	Add fuel.
		Imperfect combustion.	Remove fuel and replace with clean fuel.
		Blocked or contaminated fuel filter.	Clean or replace filter.
		Photocell fault or contaminated.	Parts need cleaning or replacing by a qualified repair person. Contact the Draper Tools Helpline for advice.
E2	Temperature Sensor Error	Temperature sensor terminal disconnected. Thermostat faulty.	Parts need replacing by a qualified repair person. Contact the Draper Tools Helpline for advice.
		Abnormal overheating.	Switch heater off and allow to cool down for at least 15minutes before restarting.
E3	Overheating Sensor Error	Product tipped or overturned.	Ensure heater is positioned on a flat and stable surface.
		Temperature below -9°C	Normal operation.
Lo	Low Temperature	Normal operation.	No action required.
CN		Nozzle blocked.	Servicing required.

8.2 Fan/Nozzle/Ignition Plug/Photocell Care & Servicing

- The heater should be inspected at least once a year by suitably qualified personnel and the fan, nozzle, ignition plug, and photocell should be checked, cleaned and replaced where necessary.
- Contact Draper Tools to discuss servicing options.
- In the event that incorrect or contaminated fuel is used in the heater, it must be replaced immediately.

8.3 Storing The Heater

- Never store the heater with fuel in the tank as this could damage the heater.
- Empty the tank and allow to dry completely before storing.
- Store the heater in a dry well-ventilated place away from children. Make sure the storage place is free of dust and corrosive fumes.

9. Spares, Returns and Disposal

For spare parts, servicing, and repair and replacement options, please contact the Draper Tools Product Helpline for details of your nearest authorised agent.

Draper Tools will endeavour to hold any spare parts, if applicable, for seven years from the date that it sells the final matching stock item.

Any servicing or repairs carried out by unauthorised personnel or installation of spare parts not supplied by Draper Tools will invalidate your warranty.

Important: For safety, **ALWAYS** drain and clean the product of any oil, fuel, chemicals or other substances before returning it to Draper Tools or its authorised agent. Store these materials in suitable containers and dispose of them in accordance with local regulations. Draper Tools and its agents cannot be responsible for the disposal of these substances.

At the end of its working life, dispose of the product responsibly and in line with local regulations. Recycle where possible.

- **DO NOT** dispose of this product with domestic waste; most local authorities provide appropriate recycling facilities.
- Dispose of fuel separately and in accordance with local regulations; **DO NOT** abandon it in the environment.



Draper Tools products are carefully tested and inspected before shipment and are guaranteed to be free from defective materials and workmanship.

Should the tool develop a fault, return the complete tool to your nearest distributor or contact Draper Tools directly. Contact information can be found at the back of this manual.

Proof of purchase must be provided.

If, upon inspection, it is found that the fault occurring is due to defective materials or workmanship, repairs will be carried out free of charge. This warranty period covers parts and labour for 12 months from the date of purchase. Where tools have been hired out, the warranty period covers 90 days from the date of purchase.

This warranty does not apply to any consumable parts, batteries or normal wear and tear, nor does it cover any damage caused by misuse, careless or unsafe handling, alterations, accidents, or repairs attempted or made by any personnel other than the authorised Draper Tools repair agent.

In all cases, to make a claim for faulty workmanship or materials within the standard warranty period, please contact or return the product to the place of purchase. Proof of purchase may be required.

If the place of purchase is no longer trading or if you experience any difficulties with your warranty, please contact Customer Services with the product details and your proof of purchase. Contact details can be found at the back of this manual.

If the tool is not covered by the terms of this warranty, repairs and carriage charges will be quoted and charged accordingly.

This warranty supersedes any other guarantees expressed or implied and variations of its terms are not authorised.

Your Draper Tools guarantee is not effective until you can produce, upon request, a dated receipt or invoice to verify your purchase within the guarantee period.

Please note that this warranty is an additional benefit and does not affect your statutory rights.

Draper Tools Limited

11. Explanation of Symbols



Read the instruction manual



Do not abandon in the environment



Warning!



WEEE –

Waste Electrical & Electronic Equipment

Do not dispose of this product with domestic waste



Do not incinerate or throw onto fire

Contact Details

Draper Tools

Draper Tools Limited
Hursley Road
Chandler's Ford
Eastleigh
Hampshire
SO53 1YF
UK

Website: drapertools.com

Email: sales@drapertools.com

Product Helpline: +44 (0) 23 8049 4344

Telephone Sales Desk: +44 (0) 23 8049 4333

General Enquiries: +44 (0) 23 8026 6355

General Fax: +44 (0) 23 8026 0784

Delta International

Delta International BV
Oude Graaf 8
6002 NL
Weert
Netherlands

Please contact the Draper Tools Product Helpline for repair and servicing enquiries.