

Stock No. Part No.  
**21263 B300-WB61** 61" Workbench

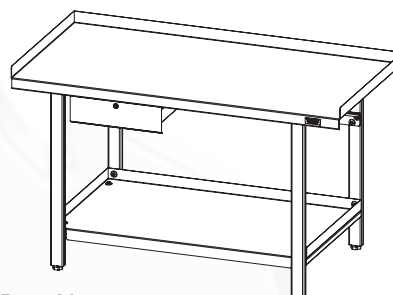

Stock No. Part No.  
**21264 B300-WB61D** 61" Workbench with Drawer

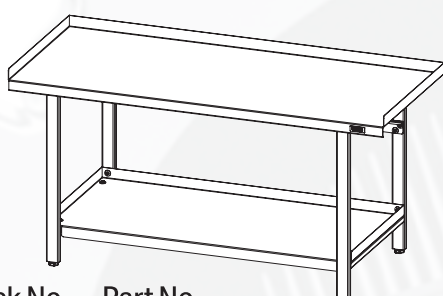

Stock No. Part No.  
**21268 B300-WB72** 72" Workbench

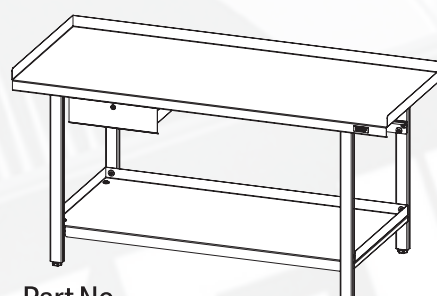

Stock No. Part No.  
**21269 B300-WB72D** 72" Workbench with Drawer

Unpack your workbench and check to make sure that it was not damaged during transit and that all items are included.

**! WARNING!** The workbench is heavy. We recommend that 2 people unpack and assemble the workbench.

### SPECIFICATIONS

Part No.	B300-WB61	B300-WB61D	B300-WB72	B300-WB72D
Dimensions	1,550 x 635 x 914 mm	1,550 x 787 x 914 mm	1,829 x 787 x 914 mm	1,829 x 787 x 914 mm

### PARTS BREAKDOWN

#### B300-WB61

Ref	Description	Qty
A	Workbench Top	1
B	Lower Shelf	1
C	Left Open Leg	1
D	Right Open Leg	1
E	Crossbar	1
F	M10 x 20 mm Bolts	16
G	Leveling Feet	4
H	Nuts	12
I	Washers	28

#### B300-WB61D

Ref	Description	Qty
AA	Workbench Top	1
BB	Lower Shelf	1
CC	Left Close Leg	1
DD	Right Close Leg	1
EE	Crossbar	1
FF	M8 x 20 mm Bolts	16
GG	Leveling Feet	4
HH	Washers	16
II	Drawer & Retaining Plate	1
JJ	Self-Tapping Screws	2

#### B300-WB72

Ref	Description	Qty
AA	Workbench Top	1
BB	Lower Shelf	1
CC	Left Close Leg	1
DD	Right Close Leg	1
EE	Crossbar	1
FF	M8 x 20 mm Bolts	16
GG	Leveling Feet	4
HH	Washers	16

#### B300-WB72D

Ref	Description	Qty
AA	Workbench Top	1
BB	Lower Shelf	1
CC	Left Close Leg	1
DD	Right Close Leg	1
EE	Crossbar	1
FF	M8 x 20 mm Bolts	16
GG	Leveling Feet	4
HH	Washers	16
II	Drawer & Retaining Plate	1
JJ	Self-Tapping Screws	2

# ASSEMBLY

## Left and Right Legs (see figures 1 & 2)

Attach the left and right legs to the workbench top and lower shelf:

1. Align the holes at the top of the legs with the holes located at the mounting bracket.
2. Insert a bolt with a washer through each of the holes of the leg and then through the mounting bracket holes.
3. Place a washer and nut onto each of the bolts and hand tighten.  
**Note:** The nuts (H) are only required when assembling the open legs.
4. Repeat the steps for the remaining leg.  
**Note:** Do not fully tighten the nuts at this time.

## Crossbar (see figures 1 & 2)

1. Attach crossbar to back of left and right legs.
2. Align crossbar end holes with the holes in the back of left and right legs.
3. Tighten bolts and washers through crossbar end holes into leg holes.  
**Note:** Do not fully tighten the nuts at this time.

## Lower Shelf (see figures 1 & 2)

1. Align the holes in the lower shelf with the holes in the legs.
2. Insert a bolt through a washer then through each of the holes in the legs and through the holes in the lower shelf.  
**Note:** Do not fully tighten the nuts at this time.
3. Set the workbench upright onto its feet. Make sure it is completely stable and resting on the legs, then fully tighten all nuts with a wrench.

## Drawer (see figure 2)

1. Install the drawer by sliding it into place on the drawer runners.
2. Once drawer is in place on the drawer runners, align the holes of the retaining plate with the holes on the rear wall of the drawer.
3. Using the two self-tapping screws, fasten the drawer retaining plate to the rear of the drawer.

Fig. 1

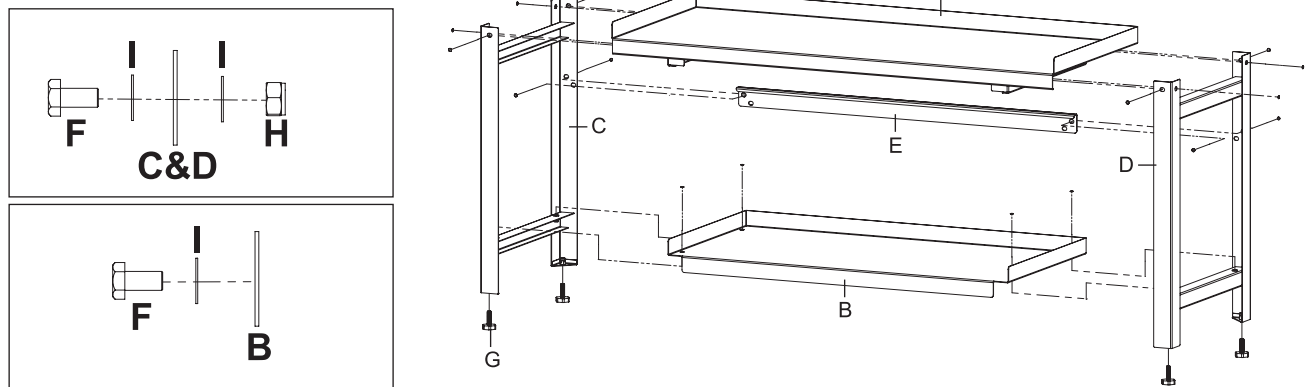

Fig. 2

