

**EN**

Original Instructions  
Version 1 – December 2023

**DRAPER**<sup>®</sup>

3-IN-1 PORTABLE

# **AIR CONDITIONER WITH REMOTE CONTROL**

**23828, 23830**



**UK  
CA** **CE**

# 1. Preface

These are the original product instructions. This document is part of the product; retain it for the life of the product, passing it on to subsequent holders. Read this manual in full before attempting to assemble, operate or maintain this product.

This Draper Tools manual describes the purpose of the product and contains all the necessary information to ensure its correct and safe use. Following all the instructions and guidance in this manual will ensure the safety of both the product and the operator and increase the lifespan of the product.

All photographs and drawings within this manual are supplied by Draper Tools to help illustrate correct operation of the product.

Every effort has been made to ensure the information contained in this manual is accurate. However, Draper Tools reserves the right to amend this document without prior warning. Always use the latest version of the product manual.

## 1.1 Product Reference

**User Manual for:** 3-in -1 Portable Air Conditioner with Remote Control

**Stock No:** 23828, 23830

**Part No:** PAC5, PAC9

## 1.2 Revisions

**Version 1:** December 2023  
First release

As our manuals are continually updated, always ensure that the latest version is used.

Please visit [drapertools.com/manuals](http://drapertools.com/manuals) for the latest version of this manual and the associated parts list, if applicable.

## 1.3 Understanding the Safety Content of This Manual



**WARNING!** – Situations or actions that may result in personal injury or death.



**CAUTION!** – Situations or actions that may result in damage to the product or surroundings.

**Important:** – Information or instructions of particular importance.

## 1.4 Copyright © Notice

Copyright © Draper Tools Limited.

Permission is granted to reproduce this manual for personal and educational use **ONLY**. Commercial copying, redistribution, hiring or lending is strictly prohibited.

No part of this manual may be stored in a retrieval system or transmitted in any other form or means without written permission from Draper Tools Limited.

In all cases, this copyright notice must remain intact.

1. Preface	2	9. Maintenance and Troubleshooting	13
1.1 Product Reference	2	9.1 Manual Drainage	13
1.2 Revisions	2	9.2 Continuous Drainage	13
1.3 Understanding the Safety Content of This Manual	2	9.3 General Cleaning	13
1.4 Copyright © Notice	2	9.4 Cleaning the Air Filter (4)	13
2. Contents	3	9.5 Troubleshooting	14
3. Product Introduction	4	9.6 Storage	14
3.1 Intended Use	4	10. Spares, Returns and Disposal	15
3.2 Specification	4	11. Warranty	15
4. Explanation of Symbols	5		
5. Health and Safety Information	6		
5.1 General Health and Safety Precautions	6		
5.2 Connection to the Power Supply	7		
5.3 Residual Risk	7		
6. Identification and Unpacking	8		
6.1 Product Overview	8		
6.2 What's in the Box?	9		
6.3 Packaging	9		
7. Before Operation	10		
7.1 Attach the Exhaust Hose	10		
7.2 Control Panel/ Display	11		
7.3 Remote Control	11		
8. Operation	12		
8.1 Start Up/Shutdown	12		
8.2 Operation Modes (2)	12		
8.2.1 Cooling Mode (3a)	12		
8.2.2 Dehumidifier/Dry Mode (3b)	12		
8.2.3 Ventilation/Fan Only Mode (3c)	12		
8.2.4 Sleep Mode	12		
8.2.5 Timer Setting – 1hour – 24hours (8)	12		
8.2.6 Automatic Defrost	12		
8.2.7 Overload Protection	12		

## 3. Product Introduction

---

### 3.1 Intended Use

This product has been designed as a portable air conditioner for cooling single rooms. It also has a ventilation function for circulating air and a dehumidifying function for the removal of moisture.

Any other application beyond the conditions established for use will be considered misuse. Draper Tools accepts no responsibility for improper use of this product.

Read this manual in full before attempting to assemble, operate or maintain the product, and retain it for later use.

### 3.2 Specification

Stock No.	23828	23830
Part No.	PAC5	PAC9
Cooling Capacity	1.5Kw (5000btu)	2.6Kw (9000btu)
Rated Input (Cooling)	560W	1005W
Circulation	260m <sup>3</sup> /hr	300m <sup>3</sup> /hr
Rated Voltage/Frequency	220 -240V/AC – 50Hz	220 -240V/AC – 50Hz
Noise Level	≤ 54dbBA	≤ 54dbBA
Net weight	19kg	22.5kg
Unit Dimensions	315 × 310 × 698mm	315 × 310 × 698mm
Remote Control batteries	2 × AAA (not supplied)	2 × AAA (not supplied)
Extraction Rate	15 litres per 24 hours	21.8 litres per 24 hours
Exhaust Hose Size	1.5m	1.5m
Suggested Room Size	8 – 12m <sup>2</sup>	12 – 18m <sup>2</sup>
Temperature Range	16 – 32°C	16 – 32°C

## 4. Explanation of Symbols



Read the instruction manual



**Warning!**



Do not incinerate or throw onto fire



**Warning!** Flammable gas.  
Risk of explosion



Mandatory action required



**DO NOT** Adjust factory settings or attempt to modify product



Keep appliance away from naked flames or sources of ignition.



Supply voltage



Input power *(stock No.23830 shown)*



Cooling rating – British Thermal Units/  
Kilowatts *(stock No.23830 shown)*



Air movement volume  
*(stock No.23830 shown)*



Suggested operational space parameters  
*(stock No.23830 shown)*



Dehumidifier moisture collection capacity  
*(stock No.23830 shown)*



Auto defrost



Auto restart



Manoeuvrable product



Refrigerant



Ingress protection rating



Product dimensions  
*(stock No.23830 shown)*



Net product weight  
*(stock No.23830 shown)*



Earthed



WEEE –

Waste Electrical & Electronic Equipment

Do not dispose of Waste Electrical & Electronic Equipment in with domestic rubbish



European conformity



UK Conformity Assessed



## 5. Health and Safety Information

---



**WARNING! Read all the Health and Safety instructions before operating, maintaining or repairing this product. Non-compliance with these instructions may result in injury or damage to the user or the product.**

### 5.1 General Health and Safety Precautions

- This appliance can be used by children aged from 8 years and above and persons with reduced physical, sensory or mental capabilities or lack of experience and knowledge if they have been given supervision or instruction concerning use of the appliance in a safe way and understand the hazards involved. Children shall not play with the appliance. Cleaning and user maintenance shall not be made by children without supervision.
  - The unit is designed only for use with R290 (propane) gas.
  - The refrigerant loop is sealed. Only a qualified technician should service it.
  - **NEVER** discharge the refrigerant into the atmosphere.
  - R290 (propane) is flammable and heavier than air. It collects first in low areas but can be circulated by the fans.
  - If propane gas is present or even suspected, only trained personnel should attempt to find the cause. R290 gas used in the unit has no odour. The lack of smell does not indicate a lack of escaped gas.
  - If a leak is detected, immediately evacuate all persons from the area, ventilate the room and contact the local fire department to advise them that a propane leak has occurred. Do not let any persons back into the room until the qualified service technician has arrived and advises that it is safe to return to the room.
  - No open flames, cigarettes or other possible sources of ignition should be used inside or in the vicinity of the unit.
  - Component parts must only be replaced with identical repair parts.
  - **DO NOT** operate with wet hands. Keep the unit away from sources or water, moisture, or any other liquids.
  - **DO NOT** unplug or tilt the unit while it is in operation.
  - **DO NOT** unplug by pulling on the power cord.
  - **DO NOT** put objects on the unit, climb or sit on the unit.
  - **DO NOT** touch or insert fingers or other objects into the air outlet.
- **DO NOT** operate the unit if it is dropped, damaged or showing signs of product malfunction.
  - **DO NOT** clean the appliance with any chemicals.
  - **DO NOT** use any means to accelerate the defrosting process or to clean, other than those recommended by the manufacture.
  - The appliance shall be stored so as to prevent mechanical damage from occurring.
  - **DO NOT** place in direct sunlight or near objects that may cause mechanical vibration or shock.
  - **DO NOT** pierce or burn, even after use.
  - Compliance with national gas regulations shall be observed.
  - Keep the air inlet and exhaust outlet clear of any obstructions.
  - Place the unit on a firm, level surface in an area with at least 50cm of free space around it to allow for proper air circulation.
  - The appliance shall be stored in a well-ventilated area where the room size corresponds to the room area as specified for operation.
-  **WARNING! Install the unit in rooms which exceed 12m<sup>2</sup>. Do not install the unit in a place where inflammable gas may leak.**
- **DO NOT** leave the unit running unattended.
-  **WARNING! Any person who is involved with working on refrigerant circuits should hold a current valid certificate from an industry-accredited assessment authority, which authorises their competence to handle refrigerants safely in accordance with an industry, recognised assessment specification.**
-  **WARNING! Servicing shall only be performed as recommended by the equipment manufacturer. Maintenance and repair requiring the assistance of other skilled personnel shall be carried out under the supervision of the person competent in the use of flammable refrigerants.**

## 5.2 Connection to the Power Supply



**WARNING! Risk of electric shock. DO NOT open this product.**

- This appliance is supplied with an approved plug and cable for your safety. The product must be installed according to national wiring regulations.
- If the power supply cord is damaged, it must be replaced by Draper Tools, an authorised service agent or similarly qualified personnel in order to avoid a hazard.
- The damaged or incomplete plug, when cut from the cable, must be disabled to prevent connection to a live electrical outlet.
- This product is Class I\* and is designed for connection **ONLY** to a power supply matching that detailed on the rating label and compatible with the plug fitted. The value of the fuse fitted is marked on the pin face of the plug. Should the fuse need replacing, ensure the substitute is of the correct rating, approved to BS 1363/A and ASTA or BS Kite marked. This should only be performed by suitably qualified personnel. ASTA BSI The fuse can be replaced by removing the cover using a small plain slot screwdriver and removing the broken fuse from its holder. This should only be performed by suitably qualified personnel.
- **DO NOT** use with an extension lead or adaptor plug.

**\*Earthed:** This product requires an earth connection to protect against electric shock from accessible conductive parts in the event of a failure of the basic insulation.

## 5.3 Residual Risk

The safety instructions in this manual cannot account for all possible conditions and situations that may occur. Exercise common sense and caution when using this product and protect against any additional conceivable risks.

## 6. Identification and Unpacking

### 6.1 Product Overview

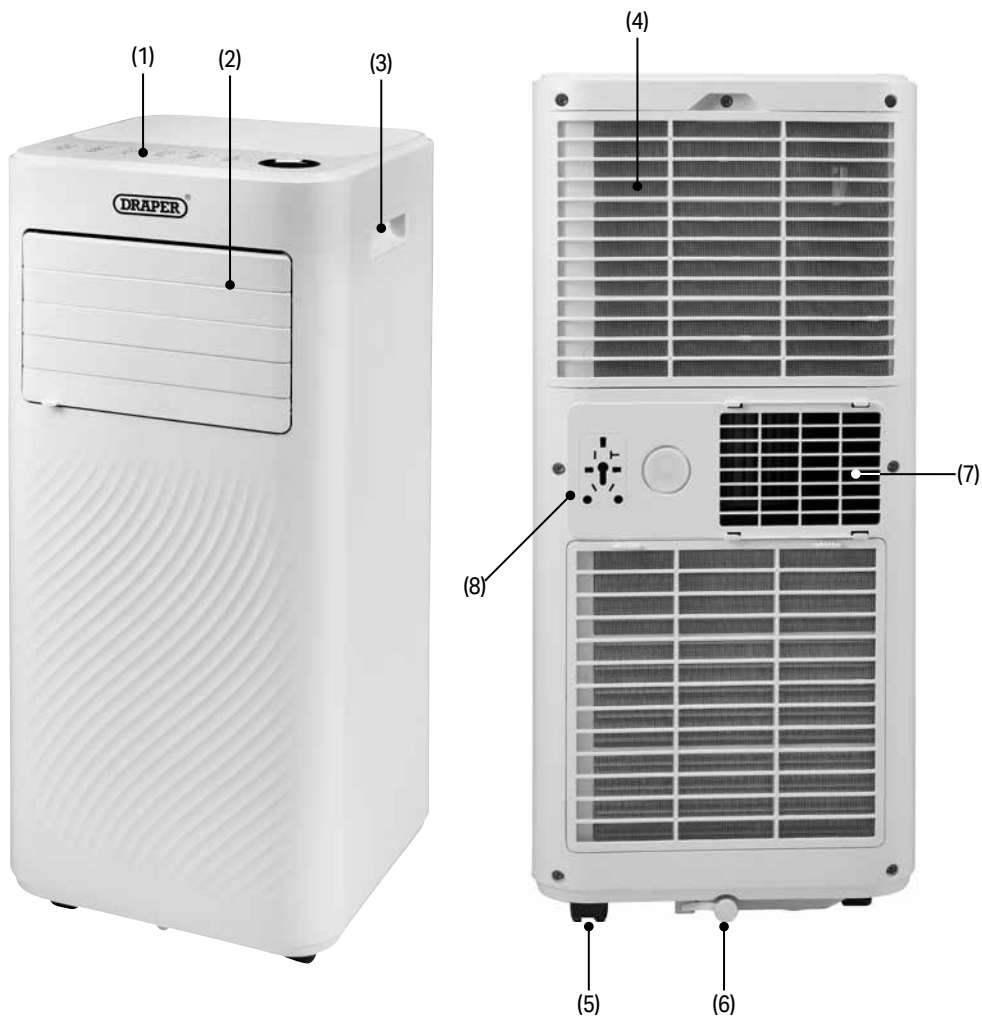

- (1) Control panel
- (2) Air outlet with adjustable louvers
- (3) Recessed handle
- (4) Air inlet with air filter
- (5) Castors

- (6) Drain valve
- (7) Air exhaust outlet
- (8) Plug storage



## 6.2 What's in the Box?

Carefully remove the product from the packaging and examine it for signs of damage that may have occurred during shipment.

Before assembling the product, lay the contents out and check them against the parts shown below. If any part is damaged or missing, do not attempt to use the product. Please contact the Draper Helpline; contact details can be found at the back of this manual.

- (A) 1 × Exhaust hose
- (B) 1 × Exhaust hose connector
- (C) Window kit hose adaptor
- (D) Window seal kit
- (E) Drainage hose
- (F) Remote control

## 6.3 Packaging

Keep the product packaging for the duration of the warranty period for reference should the product need to be returned for repair.



**WARNING! Keep packaging materials out of reach of children. Dispose of packaging correctly and responsibly and in accordance with local regulations.**

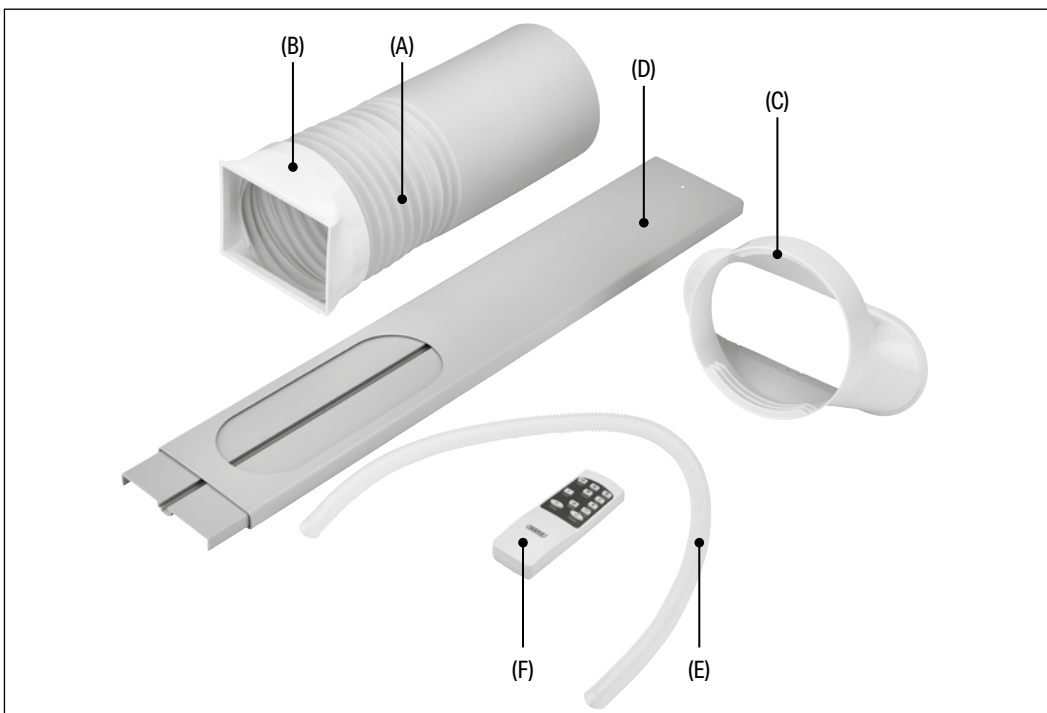

Please visit [drapertools.com](http://drapertools.com) for our full range of accessories and consumables.

# 7. Before Operation

**Important:** Before using this product, read and understand all the safety instructions listed in this manual.

- Allow the unit to stand upright for at least 24 hours before setting up.
- Place the unit on a firm, level surface in an area with at least 50cm of free space around it to allow for proper air circulation.

## 7.1 Attach the Exhaust Hose

The air conditioner requires venting outside so that the exhaust heat and moisture coming from the unit can escape the room.

Do not replace or extend the exhaust hose as this will result in decreased efficiency or cause the unit to shut down.

1. Connect the hose connector (B) to one end of the exhaust hose (A). Fig.1

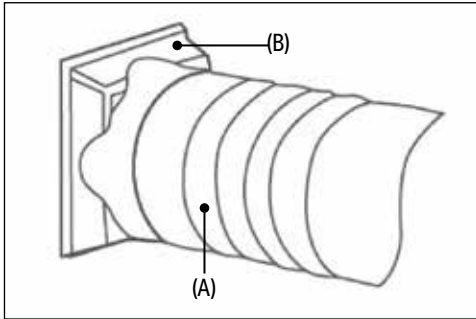

Fig. 1

2. Connect the window kit adapter (C) to the other end. Fig.2

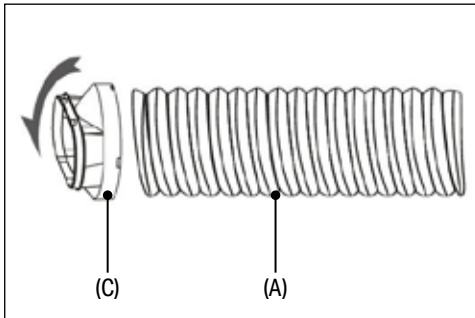

Fig. 2

3. Extend the window kit (D) to the length of your window and connect to the exhaust hose. Fig.3

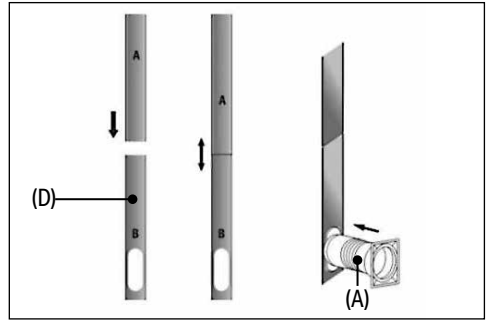

Fig. 3

4. Close your window to secure the kit firmly in place. Fig. 4

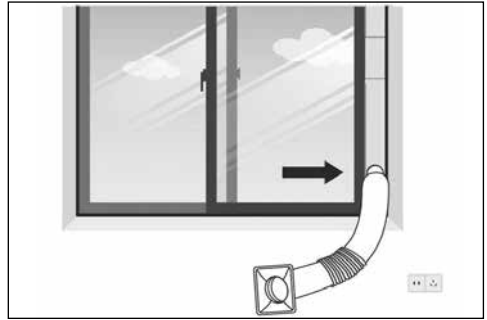

Fig. 4

5. Attach the hose connector (B) to the exhaust air outlet (7). Fig. 5

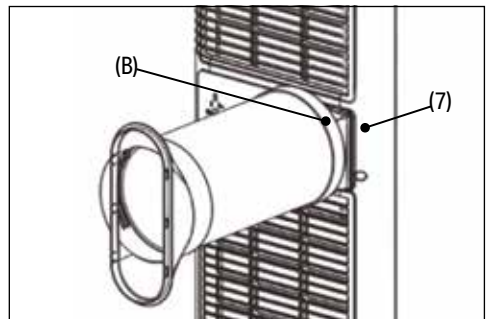
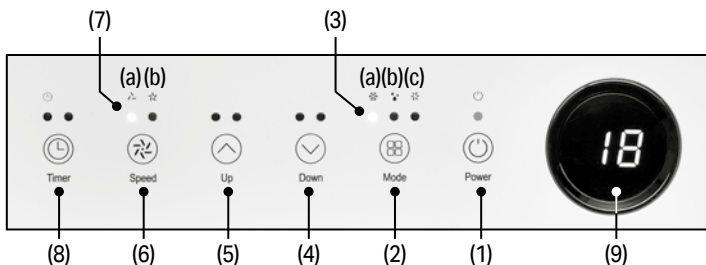

Fig. 5

6. Adjust the length of the exhaust hose - take care not to bend the hose.

## 7.2 Control Panel/ Display



1	<b>Power</b>	Switch on or off.
2	<b>Mode</b>	Switch between cool, dehumidifier or fan.
3	<b>Mode Indicator</b>	Shows mode setting selected – (a) cool, (b) dehumidifier or (c) fan.
4	<b>Down</b>	Decrease the temperature or time set.
5	<b>Up</b>	Increase temperature from 16°C – 32°C or time set.
6	<b>Fan Speed</b>	Switch fan speed from low/high.
7	<b>Fan Indicator</b>	Shows fan speed selected (a) low or (b) high.
8	<b>Timer</b>	1 hour – 24hrs – Set time for unit to automatically start or stop.
9	<b>Digital Display</b>	Shows time or temperature selected.

**Manually move the louvres to adjust the air flow direction.**

## 7.3 Remote Control

The unit can be operated using the remote control instead of using the control panel buttons.

Insert 2 × AAA batteries (not supplied) into the back of the remote control.

Ensure the batteries are fitted in the correct +/- orientation.



# 8. Operation

## 8.1 Start Up/Shutdown

1. Plug in and the display screen will come on. The indicator lights will flash and the red light above the **POWER** button will come on.
2. To select an operating mode press the **POWER** button (1) or use the remote control. **Note:** The unit will default to **FAN** mode.
3. To stop the operation press the **POWER** button again.
4. Allow the unit to completely stop before unplugging.

## 8.2 Operation Modes (2)

- The unit has three operation modes: **COOL**, **DEHUMIDIFIER (DRY)**, or **FAN**.
- To change from °C Centigrade to °F Fahrenheit either hold the **MODE** button down for 2-3 seconds or press the °C/°F button on the remote control to switch.

### 8.2.1 Cooling Mode (3a) ❄️

1. Press the **MODE** button until the **COOL** indicator lights up.
2. Press the **UP** and **DOWN** buttons to adjust the required temperature. The temperature can be set between 16°C and 32°C.
3. Press the **SPEED** button until the desired fan speed indicator light comes on.
  - Manually open the louvres to adjust the air flow direction.

**Note:** The air conditioner will stop if the room temperature is lower than the selected temperature.

### 8.2.2 Dehumidifier/Dry Mode (3b) 💧

1. Press the **MODE** button on the control panel until the dehumidifier indicator lights up. Remove the drain valve plug and connect the drainage hose (E) to the drain outlet (6) at the bottom of the unit.

**Note:** In this mode, the fan speed is on low and a temperature cannot be selected.

2. Refer to section **9.1 Manual Drainage and 9.2 Continuous Drainage** for more information on using the drainage hose.

### 8.2.3 Ventilation/Fan Only Mode (3c) 🌀

1. Press the **MODE** button until the **FAN** indicator lights up.

**Note:** In ventilation mode the room air is circulated, but not cooled.
2. Press the **SPEED** button to select the desired fan speed.

### 8.2.4 Sleep Mode

1. The **SLEEP** mode can be activated in **COOL** mode using the remote control.
2. In **SLEEP** mode: the display screen light will dim and the fan will operate at low speed.

### 8.2.5 Timer Setting – 1hour – 24hours (8)

The timer operates in two ways:

- a. **To Turn Off (when power on)** – Press the **TIMER** button to select the timer function. Then press the **UP** and **DOWN** arrows until the delay off time required is set.
- b. **To Turn ON (when power off)** – Press the **TIMER** button to select the timer function. Then press the **UP** and **DOWN** arrows until the delay on time required is set.

To cancel the timer – Press **UP/DOWN** until '00' is displayed or press the **POWER** button.

### 8.2.6 Automatic Defrost

At low room temperatures, frost may build up at the evaporator during operation. If this occurs the unit will start defrosting and the power light will blink.

The unit will automatically start defrosting and the **POWER** light will blink.

The defrost operates as follows:

- a. When the unit operates in the **COOL** or **DEHUMIDIFIER/DRY** mode, the temperature sensor will sense the evaporator coil temperature is below -1°C. The compressor will then stop operating for 10 minutes or until the temperature reaches 7°C, the unit will then restart in **COOL** mode.
- b. When the unit operates in the dehumidifying mode, once the coil temperature sensor senses the temperature of the evaporator is below 40°C and the difference between the coil temperature and room temperature is below 19°C, the compressor will operate for 20minutes. The unit will then start defrosting for 5 minutes and the **POWER** indicator will blink.

### 8.2.7 Overload Protection

In the event of a power loss, to protect the compressor there is a 3 minute delay until the compressor will restart.

## 9.1 Manual Drainage

1. The unit will automatically stop when the tank is full. Unplug before emptying the unit.
2. Move the unit carefully to avoid spilling the water.
3. Place a container for the water below the drain.
4. Remove the drain valve to allow the water to flow out into the container.

### Notes:

- During drainage, tilt the body back slightly.
- When the water has emptied, refit the drain valve.
- Always ensure the drain valve is fitted correctly before restarting the unit.

## 9.2 Continuous Drainage

The self-evaporating system uses the collected water to cool the condenser coils for more efficient performance. There is no need to empty the drainage tank in cooling mode as any condensation will evaporate and exit through the exhaust outlet.

For continuous operation in dehumidifying mode, connect the drain hose to the unit so that the water can automatically flow into a bucket or drain.

1. Switch off the unit and remove the drain valve. Retain in a safe place.
2. Securely connect the drainage hose (E), making sure it is not kinked and clear of any obstructions.
3. Place the end of the hose over a drain or bucket so the water flows freely out of the unit.
4. To prevent any air locks, do not submerge the end of the hose completely in the water.

## 9.3 General Cleaning

- Always switch off and plug the unit before cleaning.
- Clean the outer surface of the unit with a soft damp cloth and mild detergent. Wipe dry.
- Clean the air inlet and filter regularly to stop a build of dust which can have a detrimental effect on the performance of the unit.

## 9.4 Cleaning the Air Filter (4)

Dust collects on the filter can restricting the airflow and reduces the efficiency of the system. If it becomes blocked it can cause damage to the unit.

Remove and clean the air filter regularly.

**DO NOT** operate the unit without the air inlet cover fitted.

1. Switch off and unplug the unit.
2. Lift off the air inlet cover (4) with the mesh filter from the unit.



**WARNING! To avoid injury to your fingers, DO NOT touch the evaporator surface when removing the filter.**

3. Use a vacuum cleaner to suck dust from the mesh filter.
4. Refit the air inlet cover.

# 9. Maintenance and Troubleshooting

## 9.5 Troubleshooting

Problem	Possible cause	Remedy	
The unit does not operate.	Not plugged in.	Plug into power socket.	
	Auto shut off operated due to water level at maximum or 'Ft' shown on screen.	Drain the water – see <b>9.1 drainage</b> .	
Operating with reduced efficiency	Room temperature too cold or hot	Operating temperature is 5 - 35°C.	
	Air filter dirty.	Clean the air filter – <b>see 9.4</b> Recommend cleaning every 2 weeks.	
	Air duct is blocked.	Clear the obstruction.	
	Door or window opened.	Keep doors and window closed during operation.	
Water leakage	Exhaust hose not fitted.	Securely attach the hose.	
	Overflowed while moving unit.	Empty the water before moving.	
Excessive Noise	Drain hose is kinked or bent.	Straighten the drain hose.	
	Unit not positioned on a flat level surface.	Place the appliance on a flat level surface.	
Fan continues to operation after powered off	Noise sounds like flowing water.	Normal operation – noise coming from flowing refrigerant.	
	Normal operation. The compressor fan will continue to operate to blow out any remaining condensed water.	Wait a few minutes until the unit has completely stopped before unplugging.	
Error Codes			
	E0, E1, E2	Fault with unit.	Contact Draper helpline for advice.
	Ft	Condensation high level alarm.	Empty the water – <b>see 9.1</b>

## 9.6 Storage

When the appliance is not in use for an extended period, it is recommended to follow these steps:

1. Unplug and remove the exhaust hose and window kit. Store both with the main unit.
2. Drain the water and clean the filter. Allow the filter to dry before refitting.
3. Keep the appliance upright when storing. Store in a dry and well-ventilated area.

**Important:** The evaporator inside the appliance must be dried out before it is packed to avoid component damage and mould growth. Either place in a dry open area until dried out or turn on to **FAN** mode until the exhaust hose is dry.

For spare parts, servicing, and repair and replacement options, please contact the Draper Tools Product Helpline for details of your nearest authorised agent.

Draper Tools will endeavour to hold any spare parts, if applicable, for seven years from the date that it sells the final matching stock item.

Any servicing or repairs carried out by unauthorised personnel or installation of spare parts not supplied by Draper Tools will invalidate your warranty.

At the end of its working life, dispose of the product responsibly and in line with local regulations. Recycle where possible.

- **DO NOT** dispose of this product with domestic waste; most local authorities provide appropriate recycling facilities.



**WARNING! Releasing refrigerant into atmosphere is strictly forbidden!**

- **DO NOT** burn or mutilate batteries; this may release toxic or corrosive substances.
- Dispose of the battery in accordance with local regulations or return it to your warranty agent or stockist for recycling.

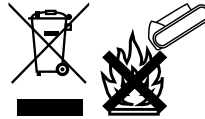

## 11. Warranty

Draper Tools products are carefully tested and inspected before shipment and are guaranteed to be free from defective materials and workmanship.

Should the tool develop a fault, return the complete tool to your nearest distributor or contact Draper Tools directly. Contact information can be found at the back of this manual.

Proof of purchase must be provided.

If, upon inspection, it is found that the fault occurring is due to defective materials or workmanship, repairs will be carried out free of charge. This warranty period covers parts and labour for 24 months from the date of purchase. Where tools have been hired out, the warranty period covers 90 days from the date of purchase.

This warranty does not apply to any consumable parts, batteries or normal wear and tear, nor does it cover any damage caused by misuse, careless or unsafe handling, alterations, accidents, or repairs attempted or made by any personnel other than the authorised Draper Tools repair agent.

In all cases, to make a claim for faulty workmanship or materials within the standard warranty period, please contact or return the product to the place of purchase. Proof of purchase may be required.

If the place of purchase is no longer trading or if you experience any difficulties with your warranty, please contact Customer Services with the product details and your proof of purchase. Contact details can be found at the back of this manual.

If the tool is not covered by the terms of this warranty, repairs and carriage charges will be quoted and charged accordingly.

This warranty supersedes any other guarantees expressed or implied and variations of its terms are not authorised.

Your Draper Tools guarantee is not effective until you can produce, upon request, a dated receipt or invoice to verify your purchase within the guarantee period.

Please note that this warranty is an additional benefit and does not affect your statutory rights.

**Draper Tools Limited**

## Contact Details

### **Draper Tools**

Draper Tools Limited  
Hursley Road  
Chandler's Ford  
Eastleigh  
Hampshire  
SO53 1YF  
UK

**Website:** [drapertools.com](http://drapertools.com)

**Email:** [sales@drapertools.com](mailto:sales@drapertools.com)

**Product Helpline:** +44 (0) 23 8049 4344

**Telephone Sales Desk:** +44 (0) 23 8049 4333

**General Enquiries:** +44 (0) 23 8026 6355

**General Fax:** +44 (0) 23 8026 0784

### **Delta International**

Delta International BV  
Oude Graaf 8  
6002 NL  
Weert  
Netherlands

Please contact the Draper Tools Product Helpline for repair and servicing enquiries.