

**EN**

Original Instructions  
Version 2

**DRAPER**<sup>®</sup>  
*Expert*

2 TONNE  
**TROLLEY  
JACK**

**27634**

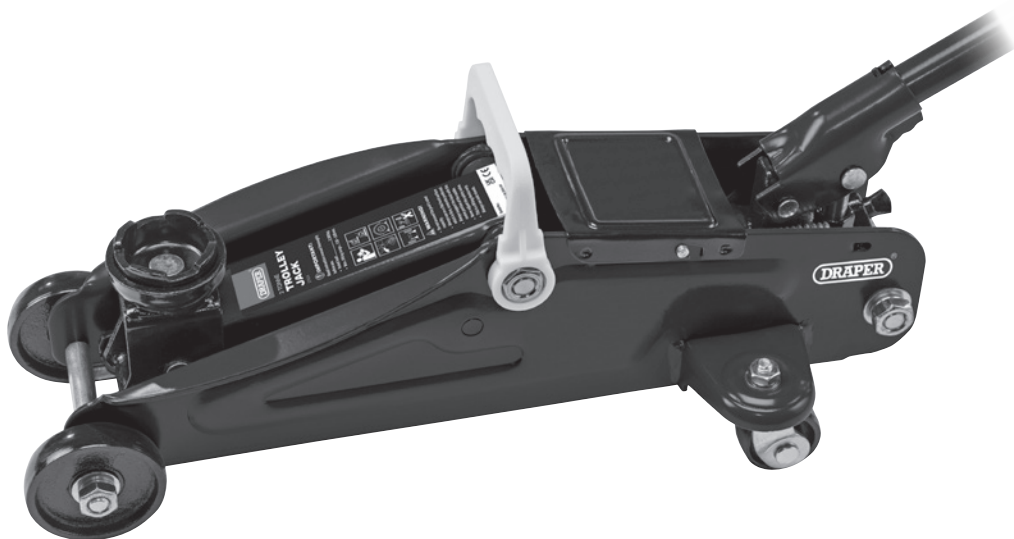

**UK  
CA** **CE**

# 1. Preface

These are the original product instructions. This document is part of the product; retain it for the life of the product, passing it on to subsequent holders. Read this manual in full before attempting to assemble, operate or maintain this product.

This Draper Tools manual describes the purpose of the product and contains all the necessary information to ensure its correct and safe use. Following all the instructions and guidance in this manual will ensure the safety of both the product and the operator and increase the lifespan of the product.

All photographs and drawings within this manual are supplied by Draper Tools to help illustrate correct operation of the product.

Every effort has been made to ensure the information contained in this manual is accurate. However, Draper Tools reserves the right to amend this document without prior warning. Always use the latest version of the product manual.

## 1.1 Product Reference

**User Manual for:** 2 Tonne Trolley Jack

**Stock No:** 27634

**Part No:** TJ2LD

## 1.2 Revisions

**Version 1:** April 2018  
First release

**Version 2:** June 2024

As our manuals are continually updated, always ensure that the latest version is used.

Please visit [drapertools.com/manuals](http://drapertools.com/manuals) for the latest version of this manual and the associated parts list, if applicable.

## 1.3 Understanding the Safety Content of This Manual



**WARNING!** – Situations or actions that may result in personal injury or death.



**CAUTION!** – Situations or actions that may result in damage to the product or surroundings.

**Important:** – Information or instructions of particular importance.

## 1.4 Copyright © Notice

Copyright © Draper Tools Limited.

Permission is granted to reproduce this manual for personal and educational use **ONLY**. Commercial copying, redistribution, hiring or lending is strictly prohibited.

No part of this manual may be stored in a retrieval system or transmitted in any other form or means without written permission from Draper Tools Limited.

In all cases, this copyright notice must remain intact.

---

1. Preface	2
1.1 Product Reference	2
1.2 Revisions	2
1.3 Understanding the Safety Content of This Manual	2
1.4 Copyright © Notice	2
2. Contents	3
3. Product Introduction	4
3.1 Intended Use	4
3.2 Specification	4
4. Health and Safety Information	5
4.1 General Health and Safety Precautions	5
4.2 Preparing the Vehicle to be Lifted	5
4.3 Correct Use of the Jack	6
5. Identification and Unpacking	7
5.1 Product Overview	7
5.2 Packaging	7
6. Operating Instructions	8
6.1 Preparing the Jack	8
6.2 Raising a Load	9
6.3 Lowering a Load	9
7. Maintenance	10
7.1 General Maintenance	10
7.2 Checking and Replacing the Oil	10
7.3 Storing the Jack	10
7.4 Troubleshooting	11
8. Spares, Returns and Disposal	12
9. Warranty	13
10. Explanation of Symbols	14
Notes	15

## 3. Product Introduction

---

### 3.1 Intended Use

This trolley jack is designed for the elevation of vehicles of up to the stated maximum weight limit as part of domestic and light-duty commercial use. Any other application beyond the conditions established for use will be considered misuse. Draper Tools accepts no responsibility for improper use of this product.

This product complies with the requirements defined by EN 1494.

Read this manual in full before attempting to assemble, operate or maintain the product, and retain it for later use.

### 3.2 Specification

Stock No.	27634
Part No.	TJ2LD
Capacity	2,000kg
Max. lifting range	130–330mm
Saddle diameter	46mm
Handle length	420mm
Chassis length	440mm
Net weight	8.3kg

**Important:** Read all Health and Safety instructions before attempting to operate, maintain or repair this product. Failure to follow these instructions may result in injury or damage to the user, the product or the vehicle to be lifted. Draper Tools accepts no responsibility for improper use of this jack.

## 4.1 General Health and Safety Precautions

- Only authorised personnel who have carefully read and understood this manual should operate this product.
- Always wear adequate protective footwear when using the jack.
- Always ensure that the working area is well illuminated and free from obstructions.
- Keep bystanders at a safe distance during operation.
- Allow a minimum distance of 0.5m between the vehicle and surrounding objects to allow the vehicle to tip when lifted.
- The wheels of this product **DO NOT** lock.
  - Ensure that the jack will not roll once positioned for use.
- Care must be taken when handling and lifting.
  - Dropping the jack may result in damage to the product or personal injury.
- **DO NOT** modify this product in any way.
- Stay alert to external interference that may cause the raised load to rock during preparation and operation.
- When not in use, lower the lifting arm, put the handle shaft into an upright position and twist it clockwise until strong resistance is felt.
  - This prevents the handle shaft from creating a trip hazard and holds it in the upright position.
  - Alternatively, lower the lifting arm, remove the handle shaft and lay it flat on the floor.

## 4.2 Preparing the Vehicle to be Lifted

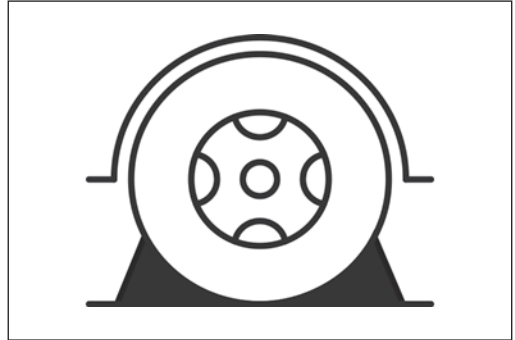

**WARNING!** **DO NOT** lift the vehicle if it may result in the spillage of dangerous substances, including fuel or battery acid.

- Ensure that there is no one inside the vehicle.
- Switch off the engine and apply the handbrake.
- Put the vehicle into gear (for manual transmission) or "Park" (for automatic transmission).
- Take any necessary precautions to prevent the vehicle from sliding.
  - Grounded wheels should be securely blocked with wheel chocks.

## 4. Health and Safety Information

### 4.3 Correct Use of the Jack

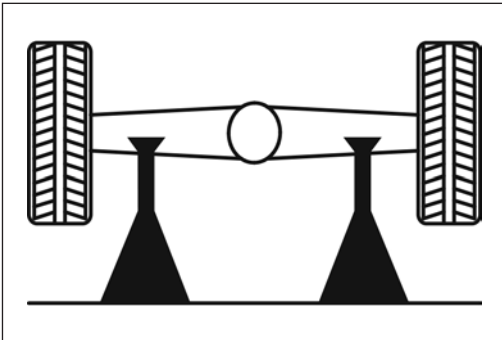
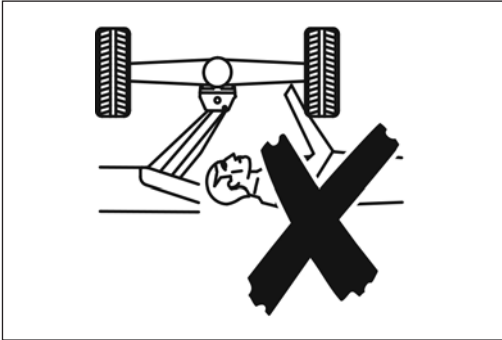
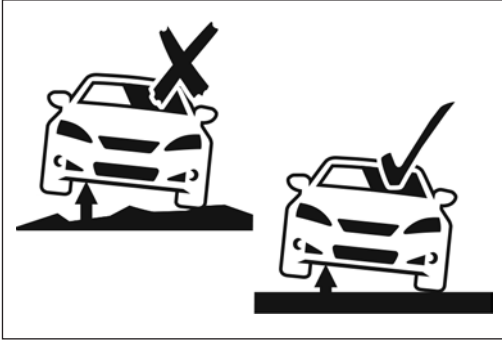

**Important:** The jack is a lifting device **ONLY** and should never be used to move the vehicle. The vehicle to be lifted should never exceed the rated capacity of the jack.

- **ALWAYS** bleed the jack piston before use.
- **ONLY** operate the jack on solid, level and horizontal surfaces.

- A concrete surface is recommended, where possible.
- All the wheels of the jack should be in contact with the operating surface when in use.

**WARNING!** Never use the jack on any surface that is slippery or may sink or rock.

- When positioning the jack, **ALWAYS** use the manufacturer's recommended lifting point.
  - These points vary between vehicles; consult the manufacturer's manual or the Haynes workshop manual for the specific vehicle information.
- Ensure that the lifting point is not dirty, greasy or corroded.
- The lifting point must remain centred over the saddle during raising and lowering; off-centred loads may slip and cause injury.
- Position the jack so that no part of the operator is required to be underneath the vehicle at any time during lifting or lowering.
- Keep clear of all movable parts of the jack mechanism when in use.
- To prevent overloading, the jack is fitted with an overload valve set at the factory.

**Important:** The overload valve should not be adjusted under any circumstances. If the capacity of the jack is exceeded, the valve will prevent the lifting operation.
- Take all precautions to prevent movement of the vehicle during raising and lowering.
  - Be aware that traffic and other external forces may cause the load to rock if used at the roadside.
- Remain alert and observe the load at all times during operation.
  - Should any dangerous conditions occur, including unexpected movement of the vehicle, cease all operation until these conditions have been rectified.
- **NEVER** work under a raised vehicle without using the correct axle supports or other appropriate supporting methods.
- **DO NOT** enter the vehicle or start the engine while it is supported on the jack or axle stand.
- **NEVER** leave the jack unattended when in use.
- **NEVER** detach the handle shaft while the jack is under load.
- **ALWAYS** ensure that there are no persons or obstacles beneath the vehicle before lowering.

## 5.1 Product Overview

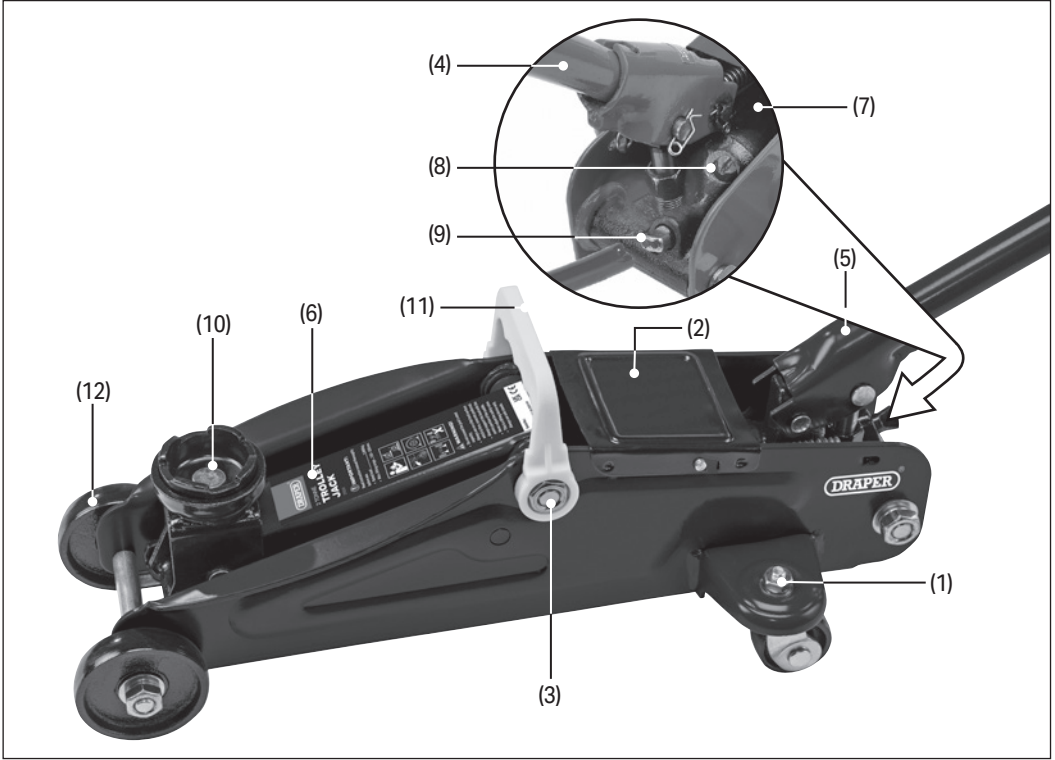

- (1) Caster bolts
- (2) Cover plate
- (3) Fulcrum bar
- (4) Handle shaft
- (5) Handle socket
- (6) Lifting arm
- (7) Oil filler plug (under cover plate)
- (8) Overload valve screw
- (9) Release valve
- (10) Saddle
- (11) Carry handle
- (12) Wheels

## 5.2 Packaging

Keep the product packaging for the duration of the warranty period for reference should the product need to be returned for repair.

**WARNING! Keep packaging materials out of reach of children. Dispose of packaging correctly and responsibly and in accordance with local regulations.**

## 6. Operating Instructions

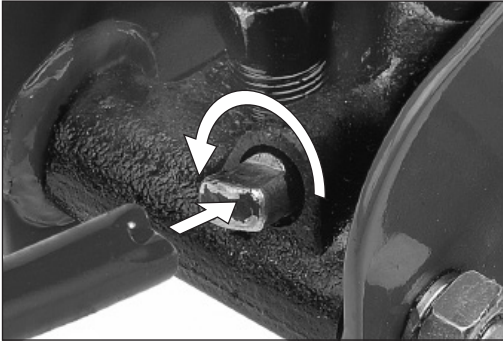

Fig. 1

Twisting the handle shaft anticlockwise opens the release valve and lowers the lifting arm (Fig. 1).

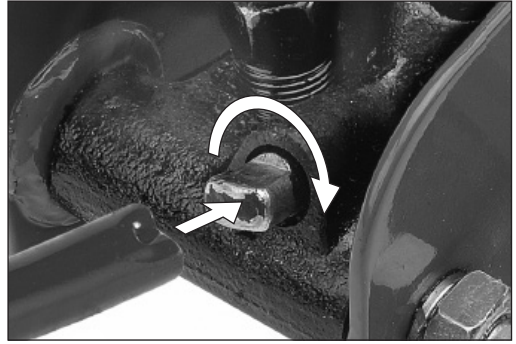

Fig. 2

Twisting the handle shaft clockwise closes the release valve (Fig. 2).

### 6.1 Preparing the Jack

Prepare the jack correctly before each use:

1. Check the jack for bent, broken, cracked or loose parts, and oil leaks; ensure that the wheels (12) rotate freely and that the caster bolts (1) are tightly fastened.



**WARNING! Do not use the product if defects are present. If it is suspected that the jack has been subjected to abnormal loads or has suffered any knocks, withdraw it from service until the product has been repaired.**

2. Unscrew the fulcrum bar (3) nuts and fit the carry handle (11) - secure in place with the nuts.  
**Important:** Ensure that the fulcrum bar nuts are securely tightened.
3. Bleed the jack piston:
  - a. Place the open end of the handle shaft (4) over the release valve (9).
  - b. Twist the handle shaft anticlockwise to open the release valve and allow the lifting to drop to its lowest position.  
**Important: DO NOT** rotate the handle shaft more than two full turns.
  - c. Remove the handle shaft from the valve and insert it into the handle socket (5), ensuring that the pins locate and lock in the socket tracks.
  - d. Pump the handle shaft up and down at least ten times using the full stroke range to lubricate the piston and expel any accumulated air.

- e. Remove the handle shaft from the socket and place it over the release valve.
  - f. Twist the handle shaft clockwise until strong resistance is felt to seal the valve.
4. Test the jack:
    - a. Insert the open end of the handle shaft into the handle socket and pump the handle shaft up and down to raise the lifting arm to its highest position.
    - b. Observe the saddle to check that it does not drop.
  5. If the lifting arm begins to drop without intervention:
    - a. Use the handle shaft to open the release valve and allow the lifting arm to drop to its lowest position.
    - b. Slide the cover plate (2) forward and lift off.
    - c. Slightly loosen the oil filler plug (7), to allow any air to escape the chamber.
    - d. Tighten the oil filler plug.
  6. Test the jack again by raising the lifting arm and ensuring that it does not drop without intervention. Repeat this process if necessary. If the issue is not resolved after several attempts, contact Draper Tools for assistance.



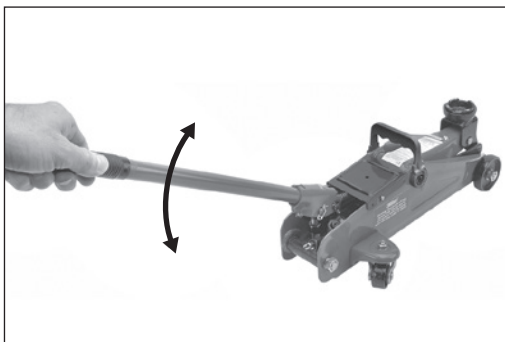

Fig. 3

Pumping the handle up and down raises the lifting arm if the release valve is closed (Fig. 3).

### 6.2 Raising a Load

1. Position the jack directly beneath the approved vehicle lifting point.  
See the vehicle manufacturer information for the approved lifting points.
2. Use the handle shaft (4) to twist the release valve (9) clockwise until strong resistance is felt.
3. Pump the handle shaft up and down until contact is made with the vehicle and check that the saddle (4) is positioned correctly.
4. With the handle shaft in the handle socket (5), pump it up and down to lift the vehicle.  
Use the full stroke range to lift more quickly.  
**Important:** If the jack drops under load, safely lower the load (see 6.3) and bleed the piston chamber (see 6.1).
5. Immediately secure the raised vehicle with an appropriate axle stand, placing it as instructed in the manufacturer information.

### 6.3 Lowering a Load



**WARNING!** Always ensure that there are no persons or obstacles beneath the vehicle before lowering.

1. Gently pump the handle shaft (4) to raise the vehicle slightly and allow the axle stand to be removed safely.
2. When the axle stand is clear, use the handle shaft to carefully twist the release valve (9) anticlockwise to gently lower the load.  
Do not turn the release valve more than a half turn at a time during lowering.

# 7. Maintenance

---

**Important:** Maintenance and repair of the jack must only be performed by qualified personnel with sufficient knowledge of the hydraulics systems used in these devices.

## 7.1 General Maintenance

- Keep the jack clean and regularly lubricate all moving parts.
  - Dust and debris may cause components to become clogged or jammed, and the product may not perform at its best.
- Protect the jack and its components from adverse environmental and weather conditions, both during use and when stored.
  - The components may rust if exposed to damp air for prolonged periods.
- Use only spare parts supplied by Draper Tools.
- Before each use, check for bent, broken, cracked or loose parts, and ensure that the wheels rotate freely.

## 7.2 Checking and Replacing the Oil

To extend the working life of the product, keep the oil at an appropriate level and replace it after periods of prolonged intensive use.



**CAUTION!** Use AW 22 hydraulic oil. Never use brake or engine oil.



**WARNING!** Oil spillage may cause the operating surface to become slippery. Do not operate the jack on oily surfaces.

To check, drain and refill the oil chamber:

1. Place the jack on a level, horizontal surface.
2. Fully lower the lifting arm (6) and handle shaft (4).
3. Remove the oil filler plug (7) and check the oil level.

**Important:** The correct oil level is 5mm below the filler plug hole.

4. If the oil is dirty or needs replacing:
  - a. Drain any remaining contents into a container.
  - b. Refill the chamber with new oil as required, keeping the oil free of dirt.



**CAUTION!** Excessive quantities of oil may render the jack inoperable.

5. Replace the oil filler plug and wipe away any excess oil.
6. Screw the cover plate back into place and return the handle shaft to an upright position.

Always drain the jack of oil before disposal. Dispose of oil according to local regulations.

## 7.3 Storing the Jack

When the jack is not in use:

- Detach the handle shaft (4).
- Ensure that the lifting arm (6) is fully lowered and apply an anti-corrosion product to the pistons if appropriate.
- Store the jack in a clean and dry location, out of reach of children.

## 7.4 Troubleshooting

Problem	Possible Cause	Remedy
The lifting arm does not raise when the handle shaft is pumped.	The release valve is not fully closed.	Use the handle shaft to twist the release valve clockwise until strong resistance is felt and bleed the piston if necessary.
	The maximum load has been exceeded.	Use an appropriately rated jack or reduce the weight of the load. <b>DO NOT</b> adjust the overload valve.
	The lifting arm fulcrum bar is not lubricated.	Use a grease gun to apply oil to the grease nipple.
	The piston system is corroded.	<b>DO NOT</b> use the jack. Contact Draper Tools to discuss repair or replacement options.
The saddle drops once lifted.	The release valve is not fully closed.	Use the handle shaft to twist the release valve clockwise until strong resistance is felt and bleed the piston if necessary.
	The hydraulics mechanism is damaged.	<b>DO NOT</b> use the jack. Contact Draper Tools to discuss repair or replacement options.
The handle shaft cannot be operated or raises the saddle slowly.	The piston system is not appropriately lubricated.	Follow steps in section 6.1.

## 8. Spares, Returns and Disposal

---

For spare parts, servicing, and repair and replacement options, please contact the Draper Tools Product Helpline for details of your nearest authorised agent.

Draper Tools will endeavour to hold any spare parts, if applicable, for seven years from the date that it sells the final matching stock item.

Any servicing or repairs carried out by unauthorised personnel or installation of spare parts not supplied by Draper Tools will invalidate your warranty.

**Important:** For safety, **ALWAYS** drain and clean the product of any oil before returning it to Draper Tools or its authorised agent. Store these materials in suitable containers and dispose of them in accordance with local regulations. Draper Tools and its agents cannot be responsible for the disposal of these substances.

At the end of its working life, dispose of the product responsibly and in line with local regulations. Recycle where possible.

- **DO NOT** dispose of this product with domestic waste; most local authorities provide appropriate recycling facilities.
- Dispose of oil separately and in accordance with local regulations; **DO NOT** abandon it in the environment.



## 9. Warranty

---

Draper Tools products are carefully tested and inspected before shipment and are guaranteed to be free from defective materials and workmanship.

Should the tool develop a fault, return the complete tool to your nearest distributor or contact Draper Tools directly. Contact information can be found at the back of this manual.

Proof of purchase must be provided.

If, upon inspection, it is found that the fault occurring is due to defective materials or workmanship, repairs will be carried out free of charge. This warranty period covers parts and labour for 12 months from the date of purchase. Where tools have been hired out, the warranty period covers 90 days from the date of purchase.

This warranty does not apply to any consumable parts, batteries or normal wear and tear, nor does it cover any damage caused by misuse, careless or unsafe handling, alterations, accidents, or repairs attempted or made by any personnel other than the authorised Draper Tools repair agent.

In all cases, to make a claim for faulty workmanship or materials within the standard warranty period, please contact or return the product to the place of purchase. Proof of purchase may be required.

If the place of purchase is no longer trading or if you experience any difficulties with your warranty, please contact Customer Services with the product details and your proof of purchase. Contact details can be found at the back of this manual.

If the tool is not covered by the terms of this warranty, repairs and carriage charges will be quoted and charged accordingly.

This warranty supersedes any other guarantees expressed or implied and variations of its terms are not authorised.

Your Draper Tools guarantee is not effective until you can produce, upon request, a dated receipt or invoice to verify your purchase within the guarantee period.

Please note that this warranty is an additional benefit and does not affect your statutory rights.

### **Draper Tools Limited**

# 10. Explanation of Symbols

---



Read the instruction manual



**Warning!**



Do not abandon in the environment



Use only on level surfaces



Apply the handbrake and put the vehicle in gear



Chock all grounded wheels



Support raised vehicles with axle stands



Do not work under vehicles when supported only by a jack



European conformity



UK Conformity Assessed



## Contact Details

### **Draper Tools**

Draper Tools Limited  
Hursley Road  
Chandler's Ford  
Eastleigh  
Hampshire  
SO53 1YF  
UK

**Website:** [drapertools.com](http://drapertools.com)

**Email:** [sales@drapertools.com](mailto:sales@drapertools.com)

**Product Helpline:** +44 (0) 23 8049 4344

**Telephone Sales Desk:** +44 (0) 23 8049 4333

**General Enquiries:** +44 (0) 23 8026 6355

### **Delta International**

Delta International BV  
Oude Graaf 8  
6002 NL  
Weert  
Netherlands

Please contact the Draper Tools Product Helpline for repair and servicing enquiries.