



DRAPER[®]

HYDRAULIC MOTORCYCLE & ATV LIFT

37777



These instructions accompanying the product are the original instructions. This document is part of the product, keep it for the life of the product passing it on to any subsequent holder of the product. Read all these instructions before assembling, operating or maintaining this product.

This manual has been compiled by Draper Tools describing the purpose for which the product has been designed, and contains all the necessary information to ensure its correct and safe use. By following all the general safety instructions contained in this manual, it will ensure both product and operator safety, together with longer life of the product itself.

All photographs and drawings in this manual are supplied by Draper Tools to help illustrate the operation of the product.

Whilst every effort has been made to ensure the accuracy of information contained in this manual, the Draper Tools policy of continuous improvement determines the right to make modifications without prior warning.

1. TITLE PAGE

1.1 INTRODUCTION:

USER MANUAL FOR: Hydraulic Motorcycle & ATV Lift

Stock No: 37777

Part No: MC/ATV2B

1.2 REVISIONS:

Date first published September 2021.

As our user manuals are continually updated, users should make sure that they use the very latest version.

Downloads are available from: <http://drapertools.com/manuals>

Draper Tools Limited
Hursley Road
Chandler's Ford
Eastleigh
Hampshire
SO53 1YF
UK

Draper Tools Limited
Oude Graaf 8
6002 NL
WEERT
Netherlands

Website: drapertools.com

Product Help Line: +44 (0) 23 8049 4344

General Fax: +44 (0) 23 8026 0784

1.3 UNDERSTANDING THIS MANUALS SAFETY CONTENT:

Warning! – Information that draws attention to the risk of injury or death.

Important – Information that draws attention to the risk of damage to the product or surroundings.

1.4 COPYRIGHT © NOTICE:

Copyright © Draper Tools Limited.

Permission is granted to reproduce this publication for personal and educational use only. Commercial copying, redistribution, hiring or lending is prohibited.

No part of this publication may be stored in a retrieval system or transmitted in any other form or means without written permission from Draper Tools Limited.

In all cases this copyright notice must remain intact.

2. CONTENTS

2.1 TABLE OF CONTENTS

1. TITLE PAGE	
1.1 INTRODUCTION.....	2
1.2 REVISIONS.....	2
1.3 UNDERSTANDING THIS MANUALS SAFETY CONTENT	2
1.4 COPYRIGHT © NOTICE.....	2
2. CONTENTS	
2.1 TABLE OF CONTENTS	3
3. WARRANTY	
3.1 WARRANTY.....	4
4. INTRODUCTION	
4.1 SCOPE.....	5
4.2 SPECIFICATION.....	5
4.3 HANDLING AND STORAGE.....	5
5. HEALTH AND SAFETY INFORMATION	
5.1 GENERAL SAFETY INSTRUCTIONS	6
5.2 RESIDUAL RISK.....	6
6. TECHNICAL DESCRIPTION	
6.1 IDENTIFICATION.....	7
7. UNPACKING AND CHECKING	
7.1 PACKAGING	8
8. ASSEMBLY & PREPARATION	
8.1 FITTING THE HYDRAULIC UNIT & FOOT PEDAL.....	9
8.2 BLEEDING THE HYDRAULIC SYSTEM	9
9. OPERATION & USE	
9.1 GENERAL OPERATIONAL PROCEDURE	10
10. MAINTENANCE	
10.1 MAINTENANCE	11
11. DISPOSAL	
11.1 DISPOSAL	12
12. EXPLANATION OF SYMBOLS	
12.1 EXPLANATION OF SYMBOLS.....	13

3. WARRANTY

3.1 WARRANTY

Draper tools have been carefully tested and inspected before shipment and are guaranteed to be free from defective materials and workmanship.

Should the tool develop a fault, please return the complete tool to your nearest distributor or contact:

Draper Tools Limited, Chandler's Ford, Eastleigh, Hampshire, SO53 1YF. England.

Telephone Sales Desk: +44 (0) 8049 4333 or Product Help Line +44 (0) 23 8049 4344.

A proof of purchase **must** be provided with the tool.

If upon inspection it is found that the fault occurring is due to defective materials or workmanship, repairs will be carried out free of charge. This warranty period covering parts/labour is 12 months from the date of purchase except where tools are hired out when the warranty period is 90 days from the date of purchase. This warranty does not apply to any consumable parts, any type of battery or normal wear and tear, nor does it cover any damage caused by misuse, careless or unsafe handling, alterations, accidents, or repairs attempted or made by any personnel other than the authorised Draper warranty repair agent.

Note: If the tool is found not to be within the terms of warranty, repairs and carriage charges will be quoted and made accordingly.

This warranty applies in lieu of any other warranty expressed or implied and variations of its terms are not authorised.

Your Draper warranty is not effective unless you can produce upon request a dated receipt or invoice to verify your proof of purchase within the warranty period.

Please note that this warranty is an additional benefit and does not affect your statutory rights.

Draper Tools Limited.

4. INTRODUCTION

4.1 SCOPE

Foot operated lever style hydraulic lifting mechanism. Rubber support arms to help prevent damage, suitable for lifting bikes, quads and all terrain vehicles.

This product is suitable for enthusiasts and tradespersons alike. Any application other than that it was intended for is considered misuse.

4.2 SPECIFICATION

Stock No.	37777
Part No.	MC/ATV2B
Safe working load	680kg
Minimum height	120mm
Maximum height	380mm
Platform size.....	335 × 330mm
Base size.....	810 × 370mm
Lift Height	260mm
Platform mat thickness	3mm
Platform mat size.....	55 × 335mm
Platform frame thickness.....	3mm
Lifting arms thickness	2.5mm
Base frame thickness	3.8mm

4.3 HANDLING AND STORAGE

- Care must be taken when handling this product.
 - This product is not a toy and must be respected.
- Environmental conditions can have a detrimental effect on this product if neglected.
 - Exposure to damp air can gradually corrode components.
 - If not cleaned and maintained correctly or regularly, the machine will not perform at its best.

5. HEALTH AND SAFETY INFORMATION

5.1 GENERAL SAFETY INSTRUCTIONS

Warning! Before use, ensure that the motorcycle to be supported has a suitable structure and centre of gravity to accommodate the platform without damaging the motorcycle. **DO NOT use if the stand will foul on the exhaust or other vulnerable parts.**

- Locate the stand in a suitable work area. Keep area clean and tidy and free from unrelated materials and ensure that there is adequate lighting. Also ensure that the floor is level and strong enough (preferably concrete) to take the weight of the stand and the bike. **DO NOT operate the stand on tarmacadam, as the surface may be unstable.**
- Keep the stand clean for best and safest performance.
- **The maximum bike weight is 680kg. DO NOT exceed this rated capacity.**
- Before lifting check that there are no overhead obstructions.
- Keep children and unauthorised persons away from the work area.
- **DO NOT use the stand for a task it is not designed to perform.**
- **DO NOT operate the stand if damaged.**
- **DO NOT exceed the rated capacity of the stand.**
- **DO NOT allow untrained persons to operate the stand.**
- **DO NOT make any modifications to the stand.**
- Before lowering the stand ensure that there are no obstructions underneath the motorcycle and that all persons are standing clear.
- Before storing, ensure that all parts are clean and free of grease and oil and the stand is fully lowered. Store stand in a safe area.

Warning! The instructions referred to in this manual are unable to cover all possible situations that may occur. It must be understood that common sense and caution are factors which are unable to build into this product, but must be applied by the operator.

5.2 RESIDUAL RISK

Important: Although the safety instructions and operating manuals for our tools contain extensive instructions of safe working with lifting equipment, every machine involves a certain residual risk which can not be completely excluded by safety mechanisms. Lifting equipment must therefore always be operated with caution!

6. TECHNICAL DESCRIPTION

6.1 IDENTIFICATION

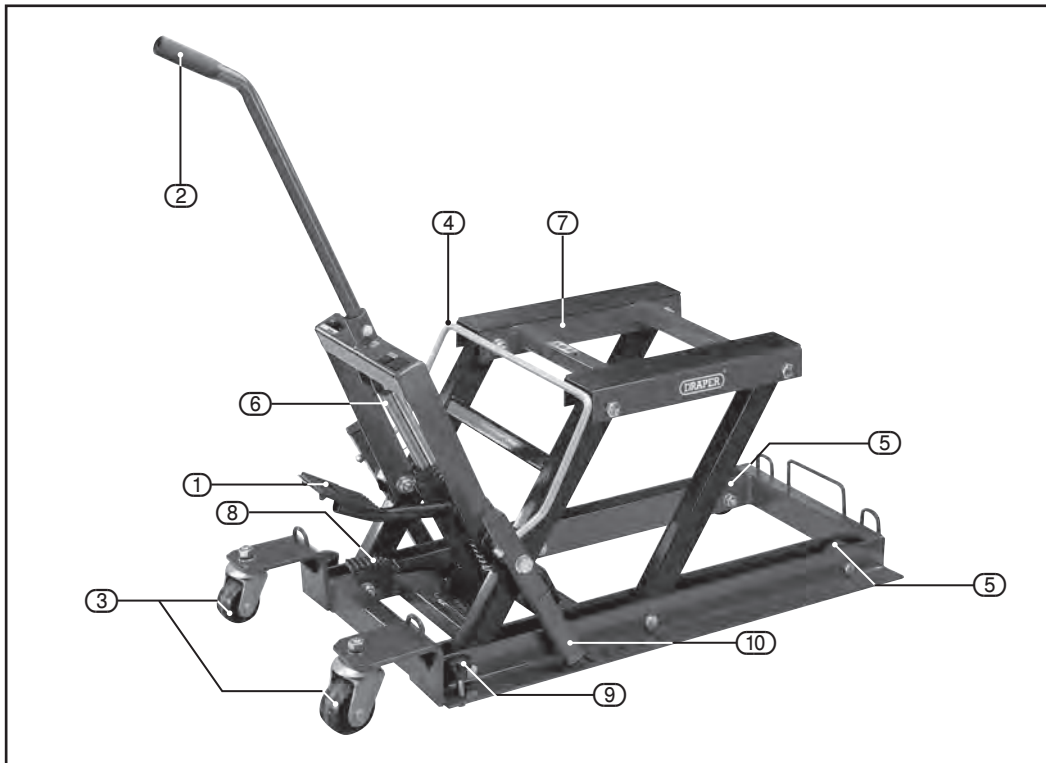

① Lift foot pedal.

② Handle.

③ Castor wheels.

④ Safety bar.

⑤ Fixed wheels.

⑥ Hydraulic ram unit.

⑦ Lift base.

⑧ Lower foot pedal.

⑨ Rear support feet.

⑩ Safety lock mechanism.

7. UNPACKING AND CHECKING

7.1 PACKAGING

Carefully remove the product from the packaging and examine it for any sign of damage that may have happened during shipping. Lay the contents out and check them against the parts shown below. If any part is damaged or missing, please contact the Draper Help Line (the telephone number appears on the Title page) and do not attempt to use the product.

The packaging material should be retained at least during the warranty period, in case the machine needs to be returned for repair.

Warning!

- Some of the packaging materials used may be harmful to children. Do not leave any of these materials in the reach of children.
- If any of the packaging is to be thrown away, make sure they are disposed of correctly, according to local regulations.

8. ASSEMBLY & PREPARATION

8.1 FITTING THE HYDRAULIC UNIT & FOOT PEDAL – FIGS.1 – 3

- Attach the hydraulic ram unit (6) to the lift base using the fixings provided. Noting that the unit will only attach in one orientation (FIG.4).
- Attach the handle (2) to the lift frame using fixing supplied.
- Locate the lift foot pedal (1) into the socket of the hydraulic ram unit (6.1) and secure using screw and washer (1.1).
- Tighten the ram bolt, attach the remaining end of the foot pedal.
- Extend the hydraulic ram unit, using the foot pedal (1) and lift the frame to allow the main pivot bolt (6.2) to be attached to the frame.
- Attach the rear castor wheels (3) to the frame.
- Check tightness of all fixings.

8.2 BLEEDING THE HYDRAULIC SYSTEM – FIG.4

Before use the hydraulic system must be bled to ensure safe operation.

- To bleed the system:
 - Pump the lift foot pedal (1) until the unit is at its maximum height.
 - While depressing the lower foot pedal (8), fully pump and release the lift foot pedal at least 10 full strokes.
 - This will purge the valve system of any air.

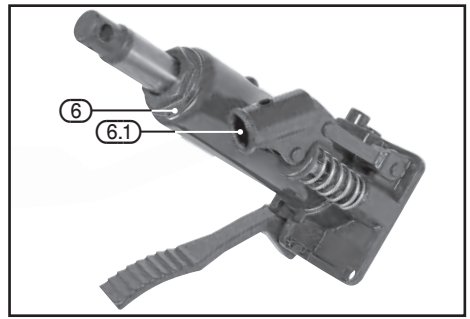

FIG.1

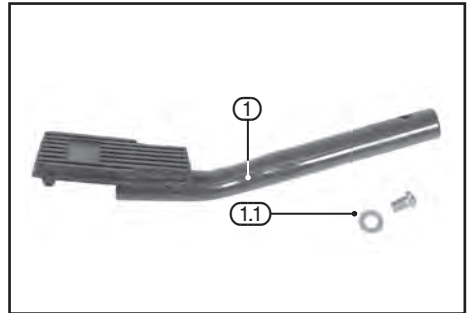

FIG.2

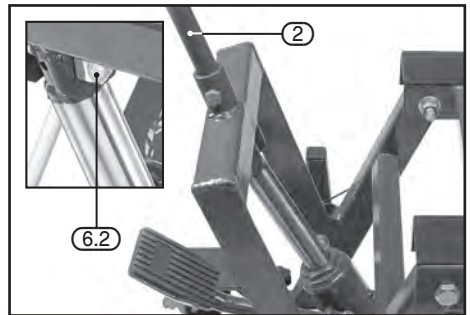

FIG.3

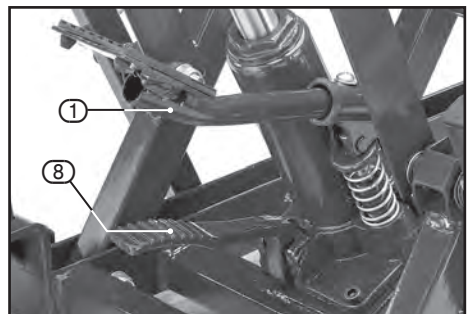

FIG.4

9. OPERATION & USE

9.1 GENERAL OPERATIONAL PROCEDURE – FIG.5

Warning! Before use, ensure you read, understand and apply the safety instructions before use.

Before use, ensure that the motorcycle has a suitable structure and centre of gravity to accommodate the stand without damaging the bike.

- **DO NOT use the stand if it will foul on the exhaust, fairing or other vulnerable parts. If necessary remove any lower fairing and ensure that the bike is stable on the stand before operating.**
- Before lifting, ensure that there is nothing above the motorcycle that could be damaged by using the lift.
- Position the bike in a suitable area, checking that the surface on which the stand will be placed is solid and flat (preferably concrete).
- Ensure there is good access and clearance beneath the bike for the stand.
- Inspect the underside of the motorcycle for suitable support points, bearing in mind the centre of gravity of the motorcycle and which wheel is to be lifted from the ground.
- Place the stand under the motorcycle in the approximate position required.
- Pump the lift foot pedal to raise the stand until the platform is just in contact with the underside of the motorcycle. Adjust the position of the stand as necessary and before lifting begins, use rear support feet to level stand and ensure load is taken away from rear castor wheels, and that the stand is fully immobilised. Only when stand is unable to move on the wheels can lifting begin.
- Pump lift foot pedal to lift motorcycle to required height, ensuring that safety lock mechanism is operating.
- While working on motorcycle ensure that it will remain stable and that the centre of gravity will not be affected by removing major/heavy components (wheels, engines etc.).
- **Warning! DO NOT move the lift while loaded as serious damage, personal injury or death may be caused. This unit IS NOT designed to transport or move items – It is a lift ONLY.**
- When work is complete, check under the stand to ensure that there are no obstructions and that it is safe to lower the unit, depress lower foot pedal gently to lower the stand.
- **When the stand is fully lowered, ensure that the bike is standing on its wheels and is supported in the upright position – BEFORE removing the lift.**



FIG.5

10. MAINTENANCE

10.1 MAINTENANCE

- When the stand is not in use, store it in the lowered position.
- Keep the stand clean and wipe off any oil or grease. Lubricate all moving parts with oil.
- Before each use check all parts. If any part of the stand is damaged or defective, remove the stand from service and take the necessary action to remedy the problem. **DO NOT** use the stand if it is believed to have been subjected to abnormal load or shock. Inspect and take appropriate action.

11. DISPOSAL

11.1 DISPOSAL

- At the end of the machine's working life, or when it can no longer be repaired, ensure that it is disposed of according to national regulations.
- Contact your local authority for details of collection schemes in your area.

In all circumstances:

- Do not dispose of this product with domestic waste.
- Do not incinerate.
- Do not abandon in the environment.



12. EXPLANATION OF SYMBOLS

12.1 EXPLANATION OF SYMBOLS



Read the instruction manual.



Wear face mask and safety glasses.



Wear ear defenders.



Do not abandon into the environment.



Keep out of the reach of children.



Maximum safe working load.



Minimum and maximum lifting height range.



Base dimensions



Pad dimensions



Net product weight
(*example shown*).



Warning!



Mandatory action required.



Maximum safe working load.



European safety standards conformity.



UK Conformity Assessed.



European conformity.

NOTES

NOTES

CONTACTS

Draper Tools Limited

UK: Hursley Road, Chandler's Ford, Eastleigh,
Hampshire. SO53 1YF. U.K.

EU: Oude Graaf 8
6002 NL Weert (NL)

Help Line: (023) 8049 4344

Sales Desk: (023) 8049 4333

Internet: drapertools.com

E-mail: sales@drapertools.com

General Enquiries: (023) 8026 6355

Service/Warranty Repair Agent:

For aftersales servicing or warranty repairs, please contact the
Draper Tools Help Line for details of an agent in your local area.

YOUR DRAPER STOCKIST

MCC0921

©Published by Draper Tools Limited.

No part of this publication may be reproduced, stored in a retrieval system or transmitted in any form or by any means, electronic, mechanical photocopying, recording or otherwise without prior permission in writing from Draper Tools Ltd.