



**DRAPER**<sup>®</sup>

DOUBLE GARAGE

# WORKSTATION

40086

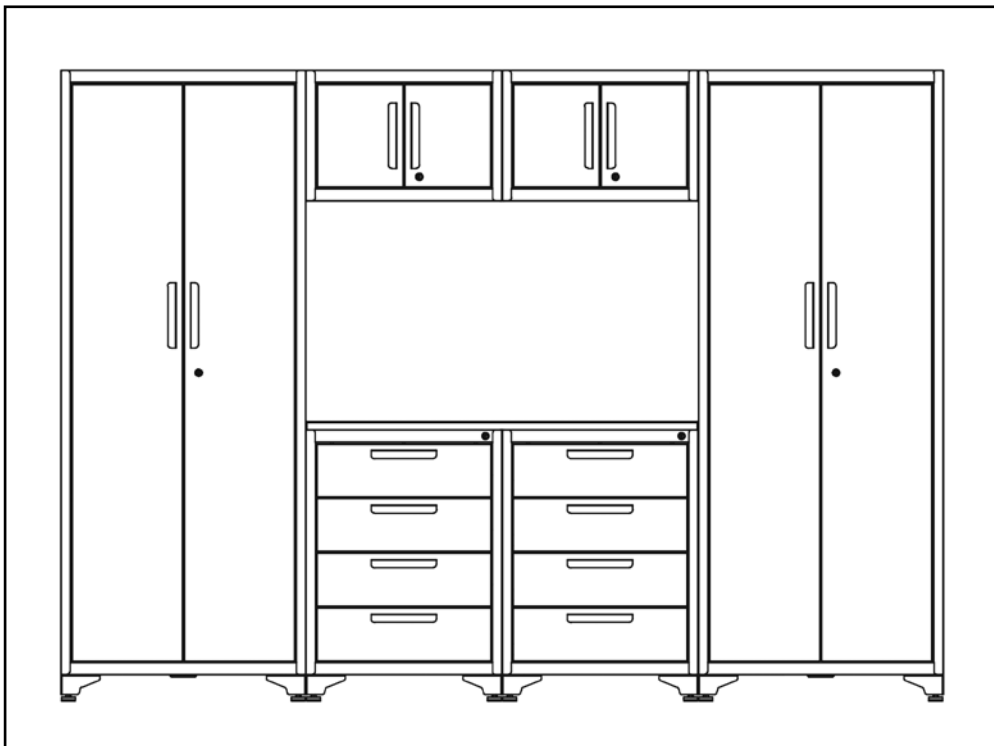

These instructions accompanying the product are the original instructions. This document is part of the product, keep it for the life of the product passing it on to any subsequent holder of the product. Read all these instructions before assembling, operating or maintaining this product.

This manual has been compiled by Draper Tools describing the purpose for which the product has been designed, and contains all the necessary information to ensure its correct and safe use. By following all the general safety instructions contained in this manual, it will ensure both product and operator safety, together with longer life of the product itself.

All photographs and drawings in this manual are supplied by Draper Tools to help illustrate the operation of the product.

Whilst every effort has been made to ensure the accuracy of information contained in this manual, the Draper Tools policy of continuous improvement determines the right to make modifications without prior warning.

# 1. TITLE PAGE

---

## 1.1 INTRODUCTION

**USER MANUAL FOR: Double Garage Workstation**

**Stock No: 40086**

**Part No: MS200**

## 1.2 REVISION HISTORY

---

**Date first published: February 2021.**

---

---

---

---

As our user manuals are continually updated, users should make sure that they use the very latest version.

**Downloads are available from:** <http://drapertools.com/manuals>

Draper Tools Limited  
Hursley Road  
Chandler's Ford  
Eastleigh  
Hampshire  
SO53 1YF  
UK

**Website:** [drapertools.com](http://drapertools.com)

**Product help line:** +44 (0) 23 8049 4344

**General Fax:** +44 (0) 23 8026 0784

## 1.3 UNDERSTANDING THIS MANUAL'S SAFETY CONTENT

**WARNING!** – Information that draws attention to the risk of injury or death.

**CAUTION!** – Information that draws attention to the risk of damage to the product or surroundings.

## 1.4 COPYRIGHT © NOTICE

Copyright © Draper Tools Limited.

Permission is granted to reproduce this publication for personal and educational use only. Commercial copying, redistribution, hiring or lending is prohibited.

No part of this publication may be stored in a retrieval system or transmitted in any other form or means without written permission from Draper Tools Limited.

In all cases this copyright notice must remain intact.

## 2. CONTENTS

---

### 2.1 CONTENTS

<b>1. TITLE PAGE</b>	
1.1 INTRODUCTION .....	2
1.2 REVISION HISTORY .....	2
1.3 UNDERSTANDING THIS MANUAL'S SAFETY CONTENT .....	2
1.4 COPYRIGHT © NOTICE .....	2
<b>2. CONTENTS</b>	
2.1 CONTENTS .....	3
<b>3. WARRANTY</b>	
3.1 WARRANTY .....	4
<b>4. INTRODUCTION</b>	
4.1 SPECIFICATION .....	5
<b>5. HEALTH AND SAFETY INFORMATION</b>	
5.1 GENERAL SAFETY INSTRUCTIONS FOR WORKSTATIONS.....	6
<b>6. TECHNICAL DESCRIPTION</b>	
6.1 IDENTIFICATION .....	7
<b>7. UNPACKING AND CHECKING</b>	
7.1 PACKAGING.....	8
7.2 WHAT'S IN THE BOX.....	8
<b>8. PREPARING THE WORKSTATION</b>	
8.1 LEVELLING FEET .....	9
8.2 ATTACHING HANDLES.....	9
8.3 CABINET CONNECTION .....	9
8.4 ATTACHING PLYWOOD TOP .....	10
<b>9. BASIC WORKSTATION OPERATIONS</b>	
9.1 REMOVING AND REPLACING THE DRAWERS.....	10
<b>10. MAINTENANCE</b>	
10.1 MAINTENANCE.....	11

## 3. WARRANTY

---

### 3.1 WARRANTY

Draper tools have been carefully tested and inspected before shipment and are guaranteed to be free from defective materials and workmanship.

Should the tool develop a fault, please return the complete tool to your nearest distributor or contact

**Draper Tools Limited, Chandler's Ford, Eastleigh, Hampshire, SO53 1YF. England.**

**Telephone Sales Desk: +44 (0) 23 8049 4333 or Product Help Line +44 (0) 23 8049 4344.**

A proof of purchase **must** be provided with the tool.

If upon inspection it is found that the fault occurring is due to defective materials or workmanship, repairs will be carried out free of charge. This warranty period covering parts and labour is lifetime from the date of purchase except where tools are hired out when the warranty period is 90 days from the date of purchase. This warranty does not apply to any consumable parts, any type of battery or normal wear and tear, nor does it cover any damage caused by misuse, careless or unsafe handling, alterations, accidents, or repairs attempted or made by any personnel other than the authorised Draper warranty repair agent.

**Note:** If the tool is found not to be within the terms of warranty, repairs and carriage charges will be quoted and made accordingly.

This warranty applies in lieu of any other warranty expressed or implied and variations of its terms are not authorised.

Your Draper warranty is not effective unless you can produce upon request a dated receipt or invoice to verify your proof of purchase within the warranty period.

Please note that this warranty is an additional benefit and does not affect your statutory rights.

**Draper Tools Limited.**

## 4. INTRODUCTION

---

### 4.1 SPECIFICATION

STOCK NO.....	40086
PART NO.....	MS200
WALL CABINET .....	600 X 320 X 400MM
STEEL THICKNESS.....	0.6MM
TALL CABINET.....	750 X 470 X 1930MM
STEEL THICKNESS.....	0.6MM & 0.9MM
4 DRAWER BASE CABINET.....	600 X 410 X 830MM
STEEL THICKNESS.....	0.6MM & 0.8MM
DRAWER INNER DIMENSIONS.....	505 X 383 X 151MM (FRONT) / 92MM (REAR)
WORK TOP .....	1200 X 427 X 25MM
WEIGHT (NET).....	158.34KG

## 5. HEALTH AND SAFETY INFORMATION

---

### 5.1 GENERAL SAFETY INSTRUCTIONS FOR WORKSTATIONS

#### Warning!

- Obtain the aid of an assistant to assemble and move this unit. Failure to do so may cause personal injury or product damage.
- **Do not** alter this product in any manner. This may cause personal injury or product damage.
- Unit must be located on a level surface. The product may become unstable and tip if stored or moved on an un-level surface, which may cause personal injury or product damage.
- **Do not** stand on this product. You may fall or cause product to tip.
- **Do not** mount this product on a truck bed or any other moving object. This may cause personal injury or product damage.
- Appropriately secure this product before moving with a forklift.
- Lock the doors/drawers if moving this product. The doors/drawers could come open and make the product unstable and tip, which may cause personal or product damage.

# 6. TECHNICAL DESCRIPTION

## 6.1 IDENTIFICATION

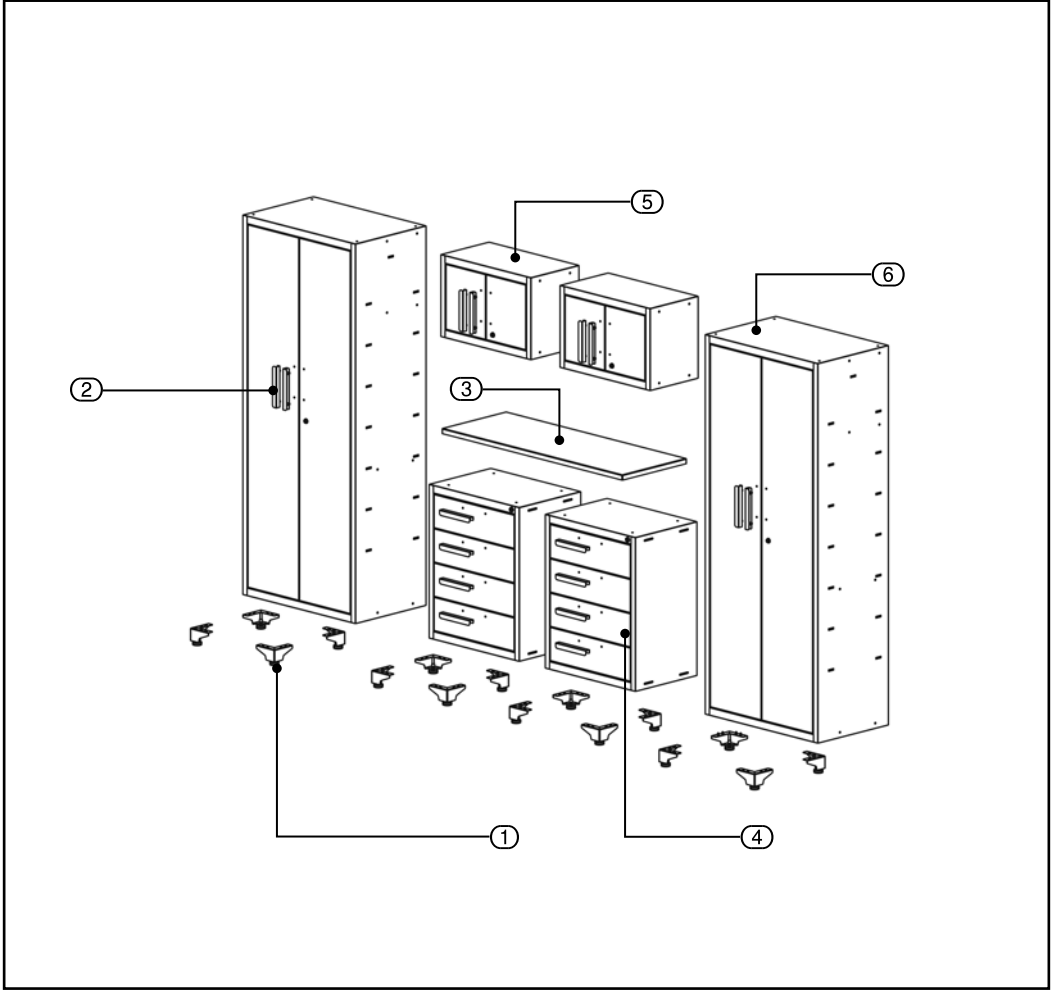

① 16 x feet holders

② 16 x handles

③ Plywood top

④ 2 x base cabinets

⑤ 2 x wall cabinets

⑥ 2 x tall cabinets

# 7. UNPACKING AND CHECKING

---

## 7.1 PACKAGING

Carefully remove the product from the packaging and examine it for any sign of damage that may have happened during shipping. Lay the contents out and check them against the parts shown below. If any part is damaged or missing, please contact the Draper Help Line (the telephone number appears on the Title page) and do not attempt to use the product.

The packaging material should be retained at least during the warranty period, in case the machine needs to be returned for repair.

### Warning!

- Some of the packaging materials used may be harmful to children. Do not leave any of these materials in the reach of children.
- If any of the packaging is to be thrown away, make sure they are disposed of correctly, according to local regulations.

## 7.2 WHAT'S IN THE BOX

As well as the workstation, there are several parts not fitted or attached to it.

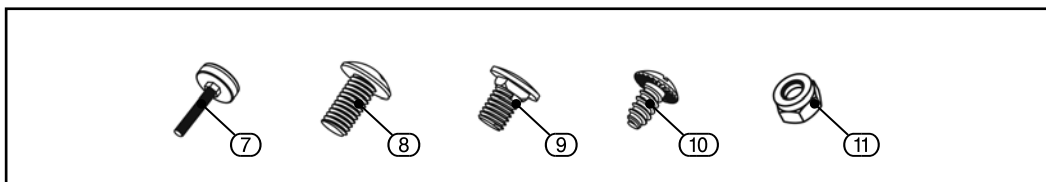

⑦ 16 x levelling feet

⑧ 32 x bolts M6 x 12mm

⑨ 32 x bolts M6 x 9mm

⑩ 64 x bolts ST6.3 x 12mm

⑪ 56 x nuts M6



## 8. PREPARING THE WORKSTATION

**Note:** To assure the squareness of the unit, do not fully tighten the screws until the cabinet is fully assembled and level.

### 8.1 LEVELLING FEET – FIG. 1

Be sure the doors and draws are locked and lay the base cabinet and tall cabinet on their backs. Use packaging material to protect the finish.

Attach the levelling foot (7) to foot holder (1). Insert bolt ST6.3 x 12mm (10) through the foot holder into the cabinet.

Do not fully tighten.

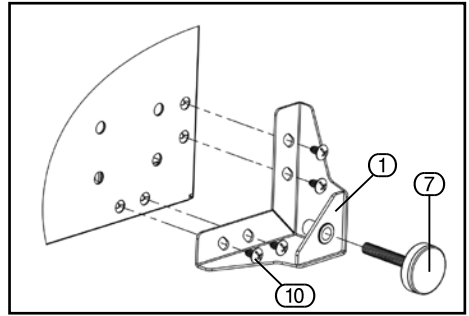

FIG. 1

### 8.2 ATTACHING HANDLES – FIGS. 2 & 3

Attach handle (2) to drawer/door front panel with bolt M6 x 9mm (9) and nut M6 (11).

Do not full tighten.

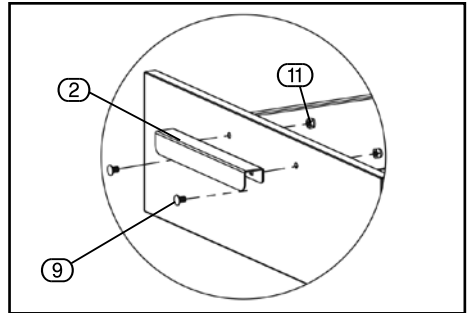

FIG. 2

### 8.3 CABINET CONNECTION – FIG. 4

Connect the side panel of two cabinets with bolt M6 x 12mm (8) and nut M6 (11).

Repeat this process on the other cabinets.

Do not fully tighten.

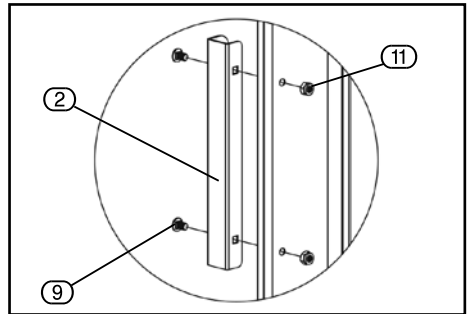

FIG. 3

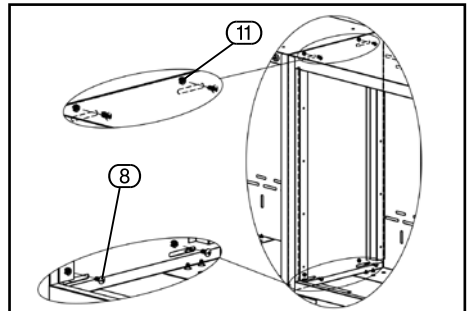

FIG. 4

## 8. PREPARING THE WORKSTATION

### 8.4 ATTACHING PLYWOOD TOP – FIG. 5

**Note:** Please remove the drawers before installing the plywood top.

Attach plywood top (3) to base cabinets with bolt M6 x 12mm (8).

Do not fully tighten.

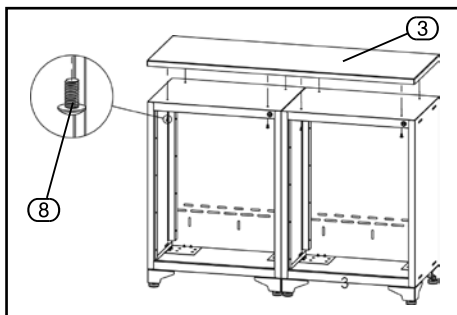

FIG. 5

## 9. BASIC WORKSTATION OPERATIONS

### 9.1 REMOVING AND REPLACING THE DRAWERS

Pull the drawer completely out. Press down the left tab and lift up the right tab. Pull drawer off sliders.

To reinstall the drawer, realign with the internal drawer slider and push in until locked in place.

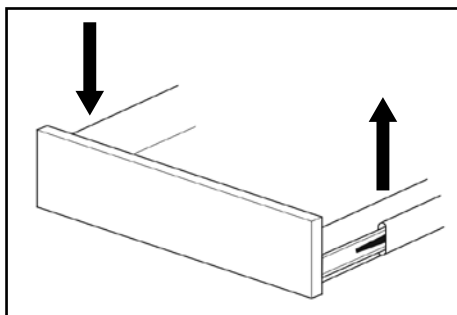

FIG. 6

# 10. MAINTENANCE

---

## 10.1 MAINTENANCE

Periodically the surfaces should be cleaned with a mild detergent and water.

Grease and oil can be removed with most standard cleaning fluids. For safety, use a non-flammable cleaning fluid.

Auto wax will preserve the lustre finish of the workbench's metal parts. Apply the wax as you would to a car. The wax will also help protect the metal parts against scratches.

## **CONTACTS**

Draper Tools Limited, Hursley Road,  
Chandler's Ford, Eastleigh, Hampshire. SO53 1YF. U.K.

Help line: (023) 8049 4344

Sales desk: (023) 8049 4333

Internet: [drapertools.com](http://drapertools.com)

E-mail: [sales@drapertools.com](mailto:sales@drapertools.com)

General enquiries: (023) 8026 6355

**Service/Warranty Repair Agent:**

For aftersales servicing or warranty repairs, please contact the Draper Tools help line for details of an agent in your local area.

YOUR DRAPER STOCKIST

DBTL0221

©Published by Draper Tools Limited.

No part of this publication may be reproduced, stored in a retrieval system or transmitted in any form or by any means, electronic, mechanical photocopying, recording or otherwise without prior permission in writing from Draper Tools Ltd.