

# REVOLVING HEAD WOOD LATHE

STOCK No.58410

PART No.WTL100A

## • INSTRUCTIONS •

**IMPORTANT:** PLEASE READ THESE INSTRUCTIONS CAREFULLY TO  
ENSURE THE SAFE AND EFFECTIVE USE OF THIS TOOL.

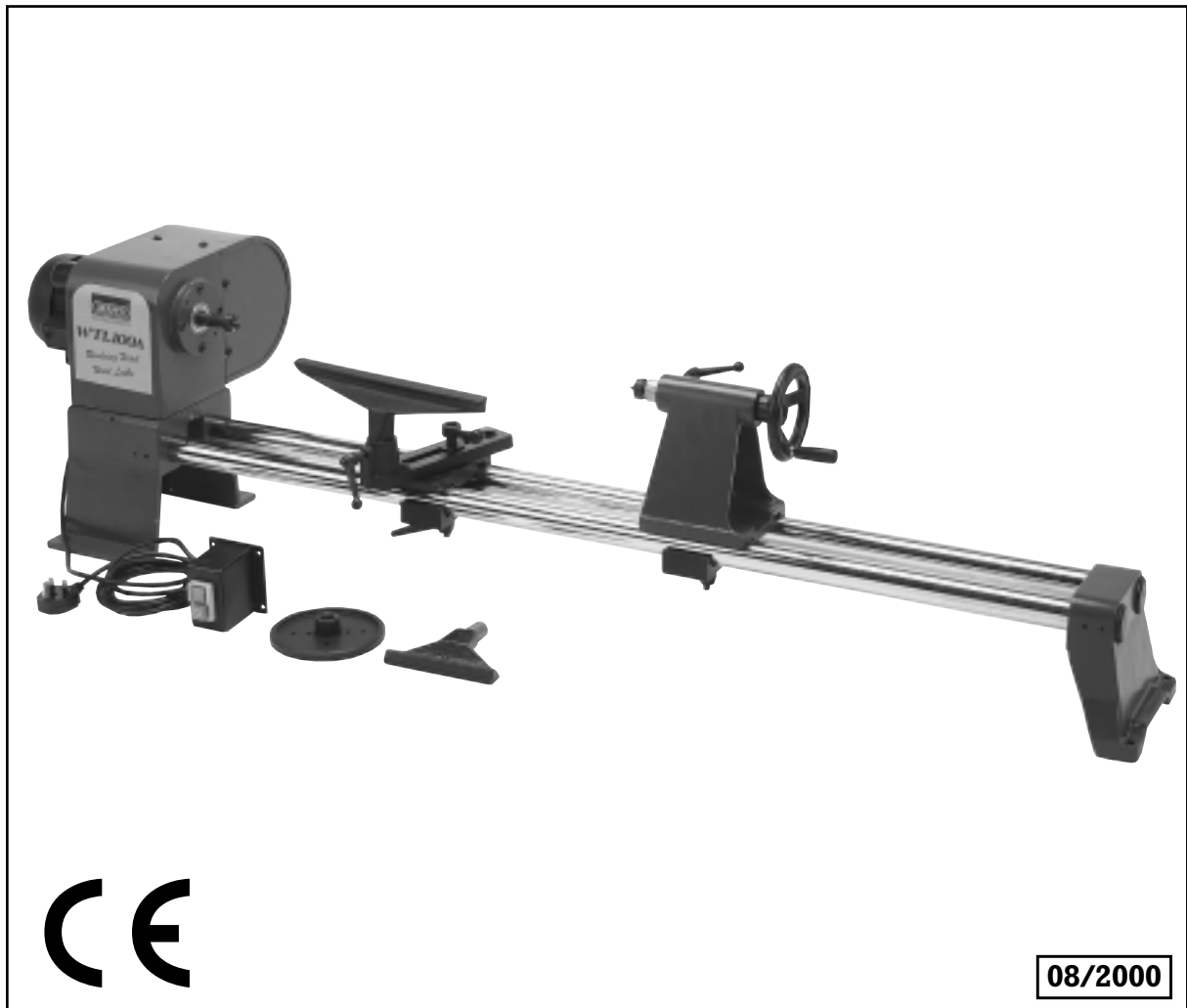



# REVOLVING HEAD WOOD LATHE

THE TOOL COMPANY ■ STOCK No.58410. ■ PART No.WTL100A

Whilst every effort has been made to ensure accuracy of information given in this manual is correct at the time of going to print, the Draper Tools policy of continuous improvement determines the right to change specification without notice.

## CONTENTS:

	Page Nos.
Declaration of Conformity .....	2
Specification / Guarantee.....	3
Power supply.....	4
General Safety Rules .....	5
Additional Safety Rules for Wood Lathes .....	6
Know Your Wood Lathe .....	6
Unpacking/Assembly .....	7-13
Wood Lathe Adjustments - Changing speeds.....	14
Wood Lathe Adjustments - Head Stock Position .....	14
Wood Lathe Adjustments - Cup Centre Adjustment .....	15
Wood Lathe Adjustments - Tool Rest .....	16
Trouble Shooting .....	17
Optional Accessories .....	17



## DECLARATION OF CONFORMITY

We  
Draper Tools Ltd. Hursley Road, Chandler's Ford, Eastleigh, Hampshire. SO53 1YF. England.

Declare under our sole responsibility that the product:

**Stock No.:-58410. Part No.:-WTL100A.**

**Description:- Revolving Head Wood Lathe.**

To which this declaration relates is in conformity with the following directive(s)98/37/EC, 73/23/EEC and 89/336/EEC.

With reference to:BS EN 60204-1:1993.

JOHN DRAPER  
Managing Director

08/2000

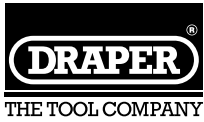

# SPECIFICATION

Stock No.....	58410
Part No.....	WTL100A
Turning Capacity Diameter.....	310mm (12")
Turning Capacity Length.....	1000mm (39")
Motor.....	370WATT
Voltage.....	230V
Speeds (RPM).....	475, 830, 1350, 2210, 3300
Spindle Taper.....	MT1
Maximum Length.....	1700mm (67")
Spindle Thread Size.....	3/4" x 16 TPI
Weight (Complete Machine) Nett/Gross.....	74/78kg
Sound Pressure Level (Max.).....	75dB(A)



# GUARANTEE

Draper machine tools have been carefully tested and inspected before shipment and are guaranteed to be free from defective materials and workmanship for a period of 12 months from the date of purchase except where tools are hired out when the guarantee period is ninety days from the date of purchase.

Should the compressor develop any fault, please return the complete tool to your nearest authorised warranty repair agent or contact Draper Tools Limited, Chandler's Ford, Eastleigh, Hampshire, SO53 1YF. England. Telephone: (023) 8026 6355.

If upon inspection it is found that the fault occurring is due to defective materials or workmanship, repairs will be carried out free of charge. This guarantee does not apply to normal wear and tear, nor does it cover any damage caused by misuse, careless or unsafe handling, alterations, accident, or repairs attempted or made by any personnel other than the authorised Draper warranty repair agent.

This guarantee applies in lieu of any other guarantee expressed or implied and variations of its terms are not authorised.



Your Draper guarantee is not effective unless you can produce upon request a dated receipt or invoice to verify your proof of purchase within the 12 month period.

Please note that this guarantee is an additional benefit and does not affect your statutory rights.

Draper Tools Limited

# POWER SUPPLY

## CONNECTING YOUR MACHINE TO A POWER SUPPLY

To eliminate the possibility of an electric shock your machine has been fitted with a BS approved, non-rewireable moulded plug and cable which incorporates a fuse, the value of which is indicated on the pin face of the plug. Should the fuse need to be replaced an  approved BS1362 fuse must be used of the same rating, marked thus . The fuse cover is detachable, never use the plug with the cover omitted. If a replacement fuse cover is required, ensure it is of the same colour as that visible on the pin face of the plug (i.e. red). Fuse covers are available from your Draper Tools stockist.

If the fitted plug is not suitable, it should be cut off and destroyed. \*The end of the cable should now be suitably prepared and the correct type of plug fitted. See below.

**\*WARNING:** A plug with bare flexible wires exposed is hazardous if engaged in a live power socket outlet.

## WARNING: THIS APPLIANCE MUST BE EARTHED

Green and yellow - Earth, Blue - Neutral, Brown - Live. As these colours may not correspond with the coloured markings identifying the terminals in your plug proceed as follows: The wire which is coloured green and yellow must be connected to the terminal in the plug which is marked with the letter 'E' or by the earth symbol or coloured green and yellow. The wire which is coloured blue must be connected to the terminal which is marked with the letter 'N' or coloured black or blue. The wire which is coloured brown must be connected to the terminal which is marked with the letter 'L' or coloured red or brown.

## EXTENSION LEAD CHART:

Extension lead sizes shown assure a voltage drop of not more than 5% at rated load of tool.

Ampere rating (on Name plate)	3	6	10	13
Extension cable length	Wire Size mm <sup>2</sup>			
7.5m	0.75	0.75	1.0	1.25
15m	0.75	0.75	1.0	1.5
22.5m	0.75	0.75	1.0	1.5
30m	0.75	0.75	1.25	1.5
45m	0.75	1.25	1.5	2.5

# WIRING DIAGRAM

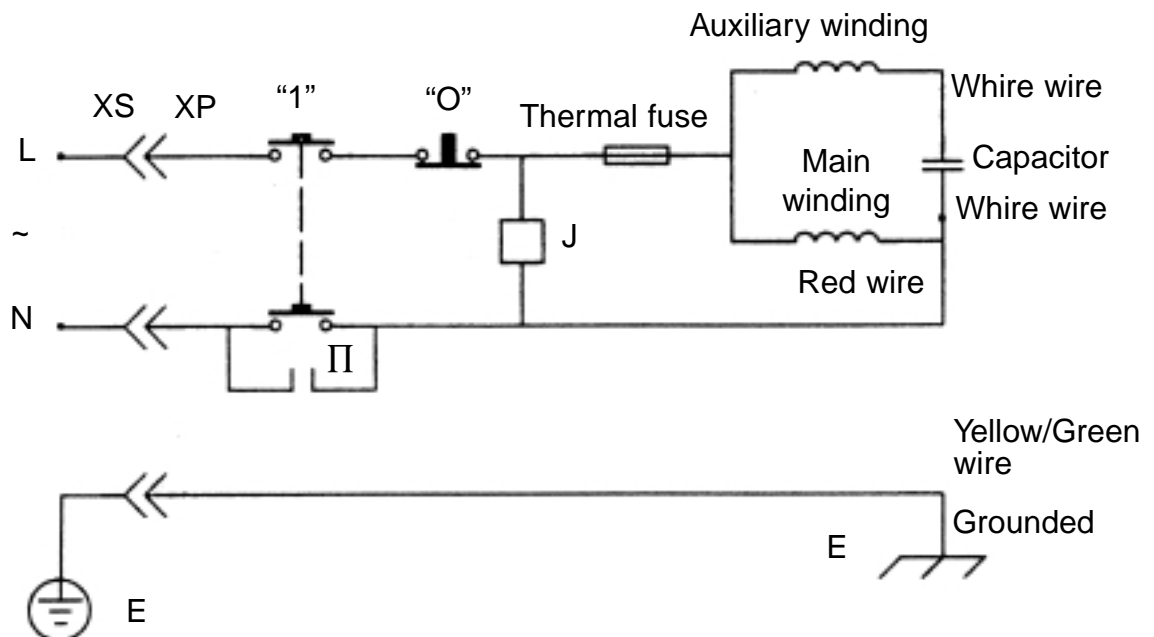

# SAFETY WARNING

## WARNING:

Please read the following instructions carefully. Failure to do so could lead to serious personal injury.

## IMPORTANT:

Draper Tools recommends that this woodlathe should not be modified or used for any application other than that for which it was designed. If you are unsure of its relative applications do not hesitate to contact us in writing and we will advise you.

# GENERAL SAFETY RULES

## 1. KNOW YOUR MACHINE TOOL

Read and understand the owner's manual and labels affixed to the tool. Learn its application and limitations as well as the specified potential hazards peculiar to this tool.

## 2. EARTH ALL TOOLS

This tool is equipped with an approved 3-core cable. The green and yellow conductor in the core is the earth wire. NEVER connect the yellow and green wire to a live terminal.

## 3. KEEP GUARDS IN PLACE

and in working order.

## 4. REMOVE ADJUSTING KEYS AND WRENCHES

For a habit of checking to see that keys and adjusting wrenches are removed from tool before turning it on.

## 5. KEEP WORK AREA CLEAN

Cluttered areas and benches invite accidents. Floor must not be slippery due to oil or sawdust.

## 6. AVOID DANGEROUS ENVIRONMENTS

Do not use power tools in damp or wet locations or expose them to rain. Keep the work area well lit. Provide adequate surrounding work space.

## 7. KEEP CHILDREN AWAY

All visitors should be kept a safe distance from work area.

## 8. MAKE WORKSHOP CHILDPROOF

with padlocks, master switches or by removing starter keys.

## 9. DO NOT FORCE TOOL

It will do the job better and safer at the rate for which it was designed.

## 10. USE RIGHT TOOL

Do not force tool or attachment to do a job for which it was not designed.

## 11. WEAR PROPER CLOTHING

Do not wear loose clothing, gloves, neckties or jewellery (rings, wristwatches) to catch in moving parts. NON SLIP footwear is recommended. Wear protective hair covering to contain long hair. Roll long sleeves above the elbow.

## 12. USE SAFETY GOGGLES (Head Protection)

Wear safety goggles (must comply with BS 2092) at all times. Normal spectacles only have impact resistant lenses, they are NOT safety glasses. Also use a face mask or dust mask if cutting operation is dusty and ear protectors (plugs or muffs) during extended periods of operation.

## 13. SECURE WORK

Use clamps or a vice to hold work. This frees both hands to operate tool.

## 14. DO NOT OVERREACH

Keep proper footing and balance at all times.

## 15. MAINTAIN TOOLS WITH CARE

Keep tools sharp and clean for best and safest performance. Follow instructions for lubricating and changing accessories.

## 16. DISCONNECT POWER TO THE TOOLS

Before servicing, when changing accessories such as cutters etc.

## 17. AVOID ACCIDENTAL STARTING

Make sure switch is in 'OFF' position before plugging in the cable to the power supply.

## 18. USE RECOMMENDED ACCESSORIES

Consult the owner's manual for recommended accessories. Follow the instructions that accompany the accessories. The use of improper accessories may cause hazards.

## 19. NEVER STAND ON TOOL

Serious injury could occur if the tool is tipped or if the cutting tool is accidentally contacted. Do not store materials above or near the tool such that is necessary to stand on the tool to reach them.

## 20. CHECK DAMAGED PARTS

Before further use of the tool, a guard or other part that is damaged should be carefully checked to ensure that it will operate properly and perform its intended function. Check for alignment of moving parts, breakage of parts, mounting and any other conditions that may affect its operation. A guard or other part that is damaged should be properly repaired or replaced.

## 21. DIRECTION OF FEED

Feed work into a blade or cutter against the direction of rotation of the blade or cutter only.

## 22. NEVER LEAVE THE MACHINE RUNNING UNATTENDED

Turn power off. Do not leave the machine until it comes to a complete stop.

## ADDITIONAL SAFETY RULES FOR WOOD LATHES

FOR YOUR OWN SAFETY: Read and understand this instruction manual before operation.

1. Always wear eye protection which complies to a recognized standard.
2. Wear a mask or respirator when dust is generated.
3. Keep hands clear of moving parts.
4. Only use Draper approved accessories and spare parts.
5. Keep turning chisels sharp.
6. Keep guards in place and working properly.
7. Never reach behind or beneath the workpiece.
8. Disconnect from the power supply before adjusting or servicing.
9. To avoid electric shock do not use in damp conditions.

## KNOW YOUR WOOD LATHE

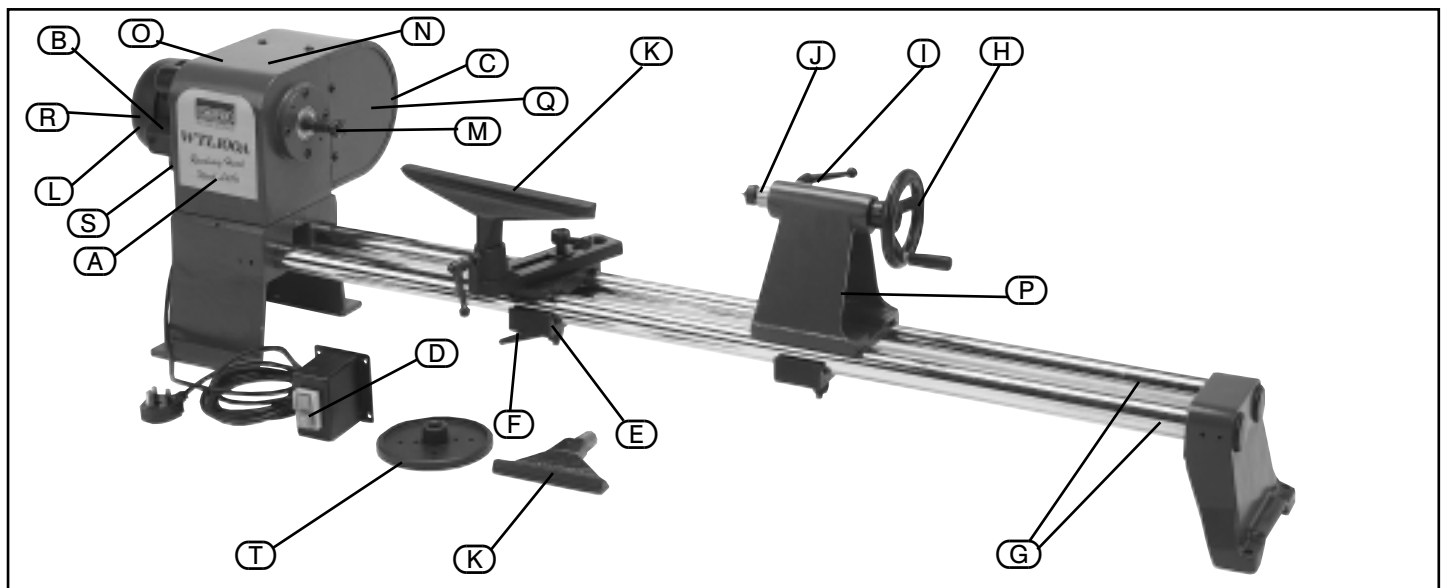

- |   |  |
|---|--|
| (A) Nameplate.  | (K) Tool rests, 6" and 12" supplied - supports chisel. |
| (B) Drive belt.   | (L) Motor.   |
| (C) Motor pulley - 5 speed manual change.                                     | (M) Drive spur - drive centre for workpiece.           |
| (D) ON/OFF No Volt Switch.  | (N) Spindle pulley - 5 speed manual change.            |
| (E) Tool rest clamping bracket.   | (O) Pulley cover - protects user from moving parts.    |
| (F) Tool rest lock handles - locks rest in required position.                 | (P) Tailstock assembly - supports long workpieces.     |
| (G) Bed bars - supports tailstock/tool rest.                                  | (Q) Headstock.   |
| (H) Tailstock adjustment handle wheel.  | (R) Spindle.   |
| (I) Tailstock adjustment locking handle - locks tailstock barrel in position. | (S) Belt tension lever.                                |
| (J) Live centre - acts as a pivot for the free end of the workpiece.          | (T) Face plate.  |

## UNPACKING AND CHECKING CONTENTS

Carefully unpack the wood lathe and all the loose parts from the carton. Fig.1. illustrates the wood lathe and all the associated parts that are packed in the carton. Now check that all the parts are present.

Fig.1.

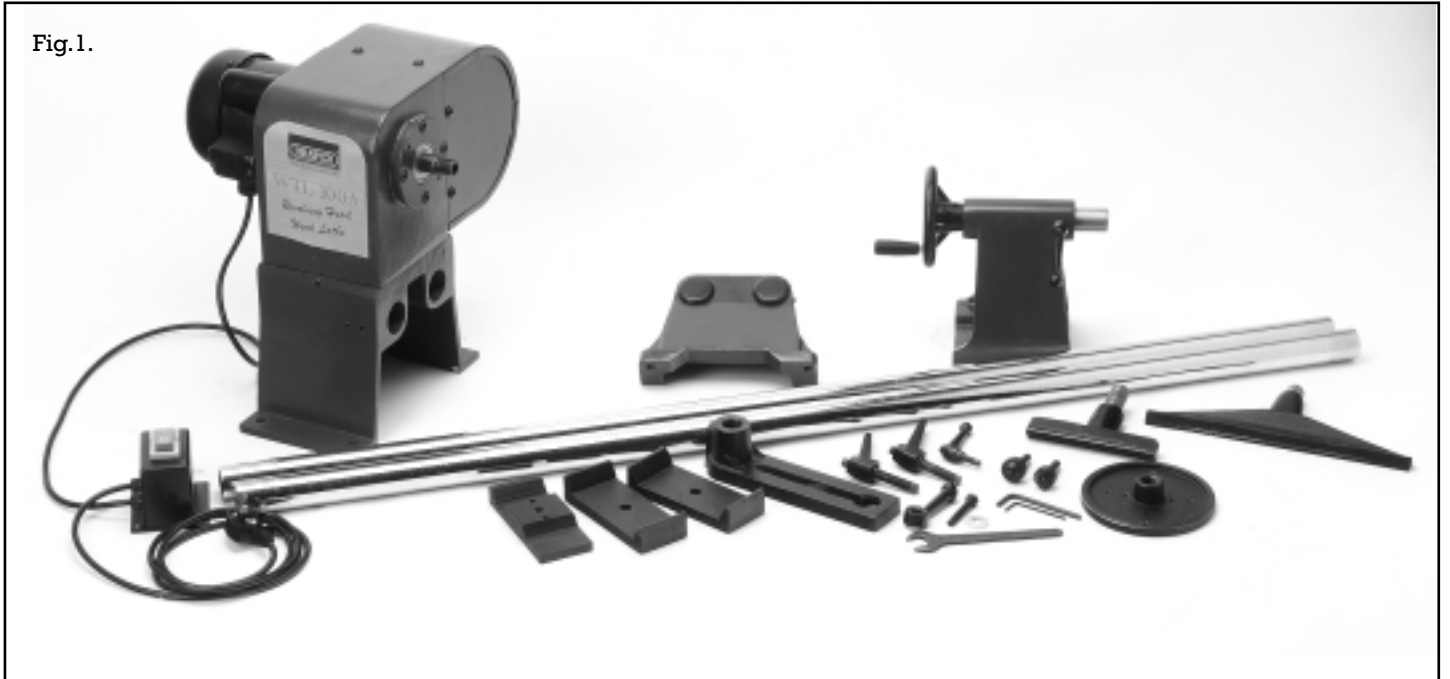

Please contact the Draper stockist where your purchase was made if you have any enquiries, eg problems with assembly, missing/damaged parts, help with accessories available or technical advice or alternatively, call the Draper Helpline on (023) 8049 4344.

**IMPORTANT:**

To correctly assemble and adjust this wood lathe, please read the following instructions carefully.

**NOTE** - To secure the wood lathe to a workbench or stand, you will need to obtain nuts, bolts and washers (these are not supplied).

**SECURING:** Position the wood lathe on the workbench/stand (optional accessory) before drilling the locations holes, this will ensure correct alignment. Mark and drill four holes (A) (Figs.2 & 3) in the top of the workbench/stand to the required size as shown. Ensure the headstock is positioned so that you do not drill into the legs or support rails underneath.

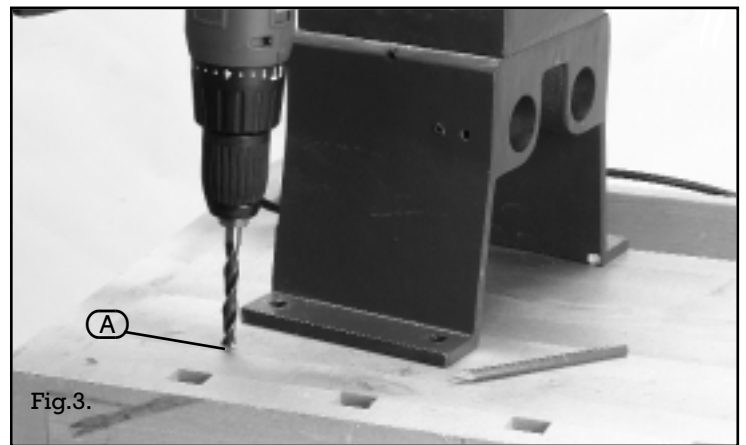

Carefully lift the headstock (B) Fig.4. onto the workbench/stand. Now line up the holes in the base of the headstock with the holes you have drilled in the top of the workbench/stand. Insert one bolt (D) into each of the four holes. Now place a flat washer, lock washer and nut onto each of the bolts. Tighten nuts finger tight only.

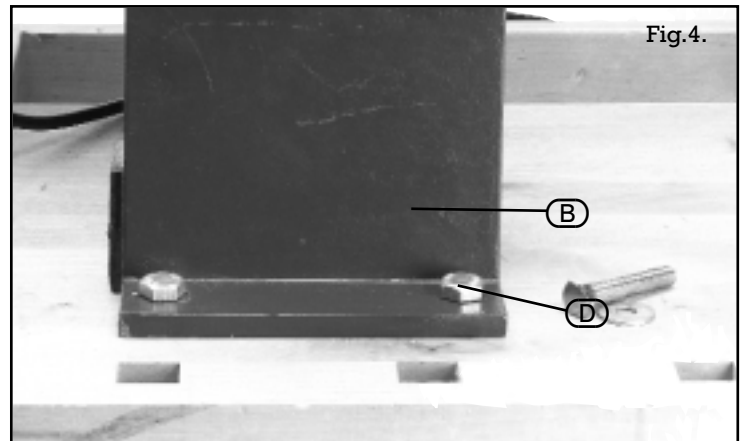

From the loose parts, locate the two bed bars (E), bed bar foot (F) and grub screws (G) Fig.5.

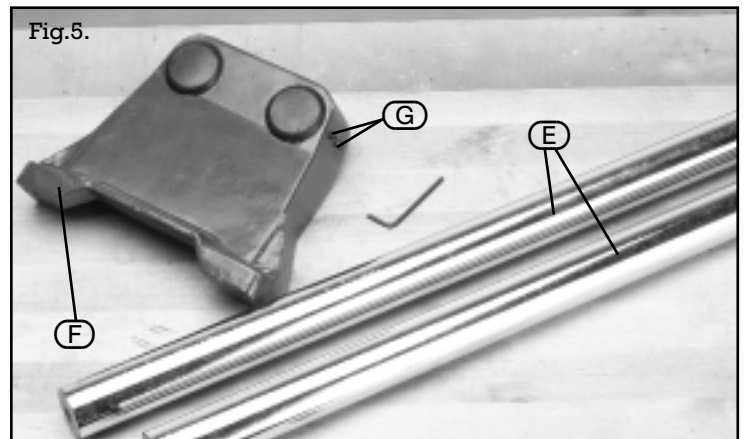



# ASSEMBLY Cont'd.

Place each of the bed bars (E) into the holes (H) located in the bed bar foot and secure by tightening the hexagon socket head screws (G) as shown in Fig.6.

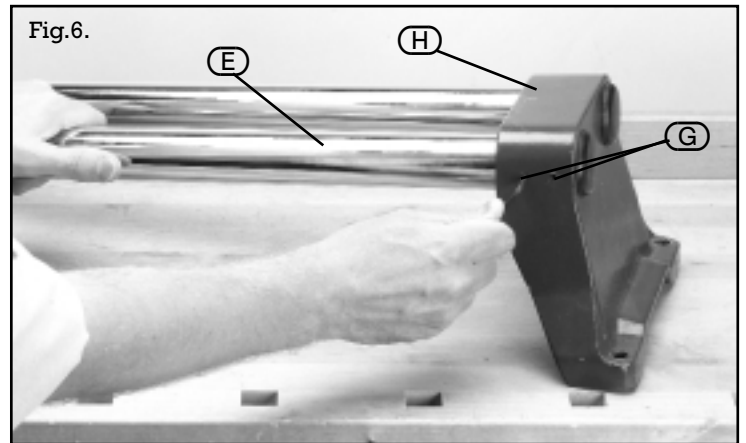

Now slide the bed bars into the headstock and secure by tightening the two hexagon socket head screws (I) see Fig.7.

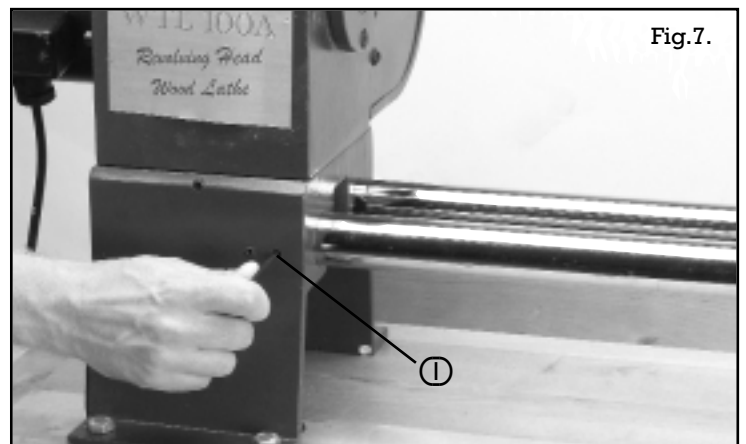

Next, from the loose parts supplied locate the following parts; tailstock assembly (J), locking handle (L) and (K), base plate (M), hand wheel (N) and finally centre cup (O) see Fig.8.

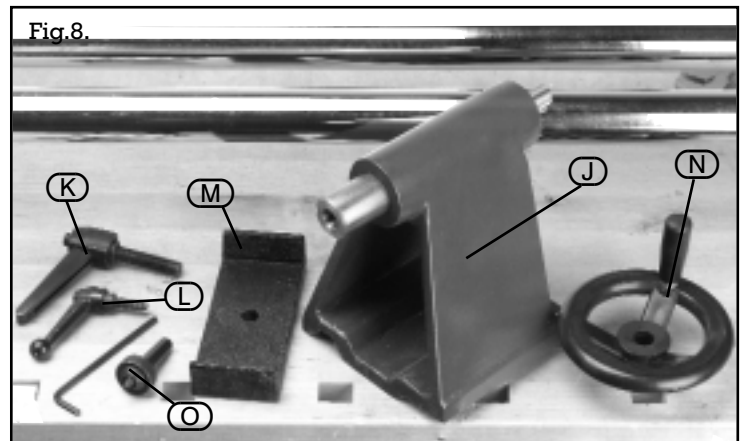

Place the tailstock assembly (J) on the bed bars as shown in Fig.9.

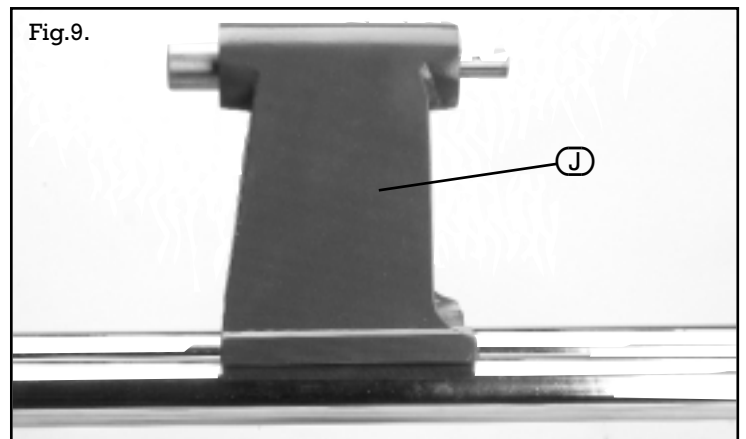

Then secure in place using the base plate (M) and locking handle (K) as shown in Fig.10.

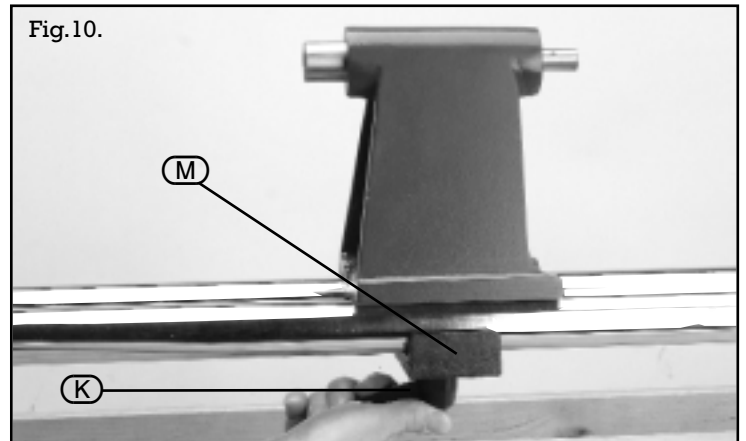

Secure the handwheel (N) to the tailstock assembly by tightening the hexagon socket head screw (P) as shown in Fig.11.

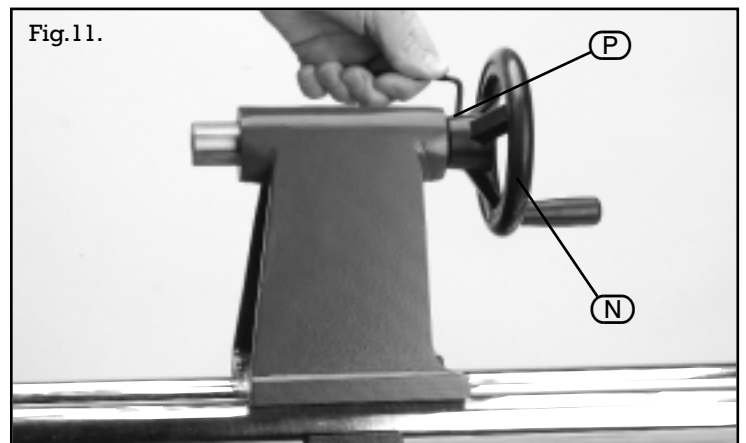

Slide the centre cup (O) into the tailstock barrel as shown in Fig.12. Note: do not drive or hammer the centre cup into the tailstock barrel as removal maybe difficult. Use a soft faced hammer and a block of wood to gently tap it in as shown in Fig.12.

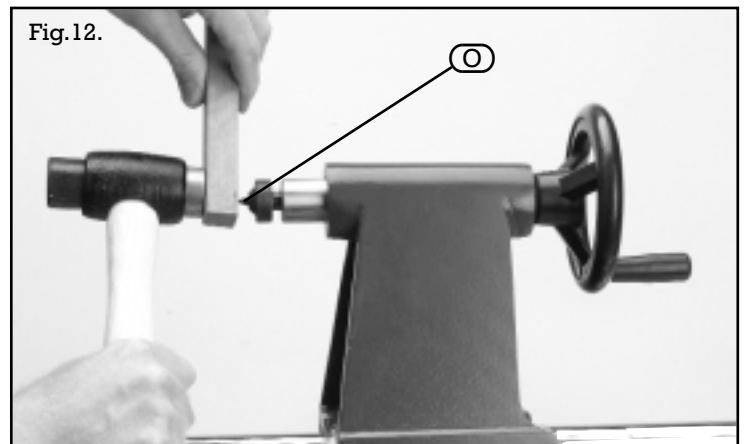

To remove the centre cup from the tailstock barrel insert the ejection pin (supplied), a small wooden dowel or brass rod into the rear of the barrel. Hold the cup with one hand and gently tap the pin with the hammer until it is released. See Fig.13.



Finally insert locking handle (L) as shown in Fig.14.

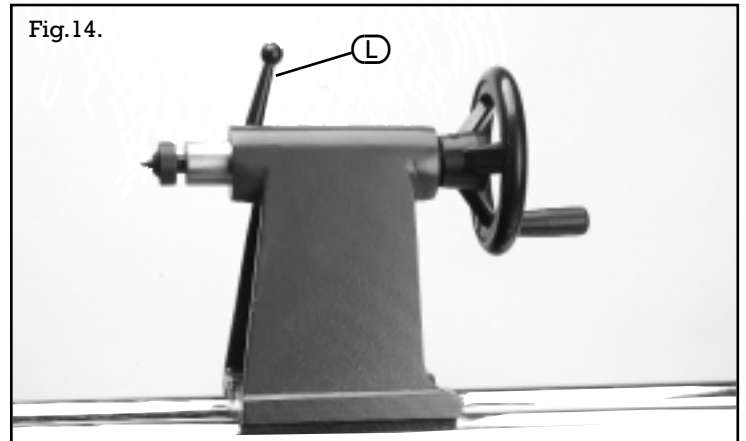

Now locate the following from the loose parts supplied with the wood lathe; tool rest (Q), base plate (R), locking handle (S), top plate (T), locking handle (U), tool rest support (V), bolt (W) and finally handle (X). See Fig.15.

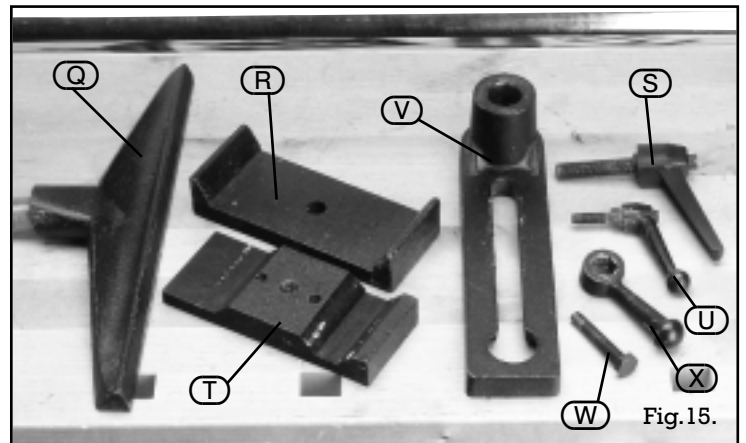

Secure the base plate (R) to the top plate (T) using the locking handle (S) as shown in Fig.16.

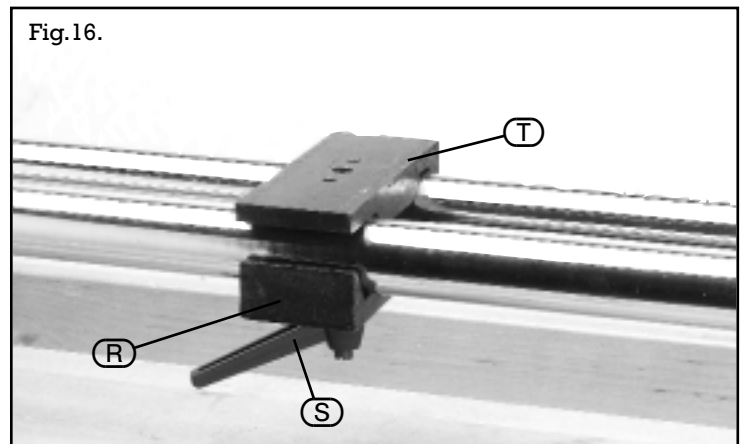

The tool rest support can now be attached to the top plate as shown in Fig.17 using the bolt (W) and handle (X).

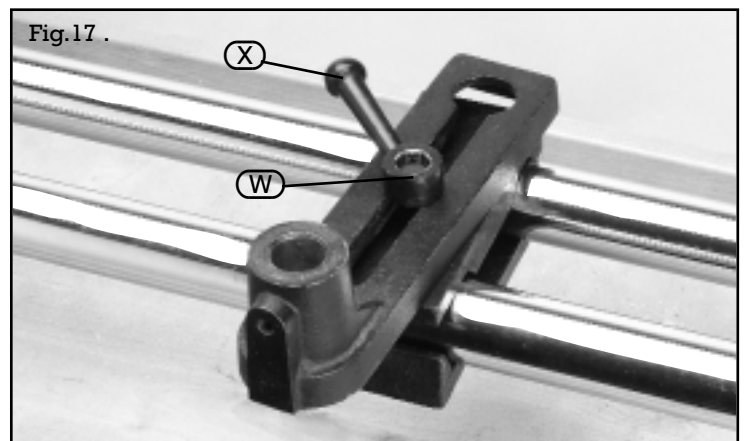

Finally insert the tool rest (Q) into the support and secure using locking handle (U) Fig.18.

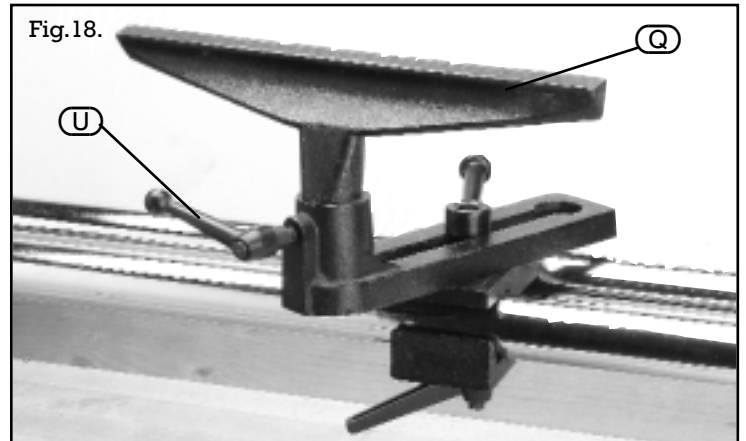

Now locate the headstock spindle. Note: Do not drive or hammer the drive centre into the spindle as removal may be difficult. Use a soft faced hammer and a piece of softwood as shown in Fig.19.



To remove the drive spur from the headstock spindle insert the ejection pin, a wooden dowel or brass rod through the hole in the rear of the headstock, hold the drive spur with one hand and gently tap the dowel or rod with a hammer until it is released. See Fig.20.



Tighten the four nuts and bolts (Y) Fig.21 so that the headstock is securely fixed to the workbench/stand.

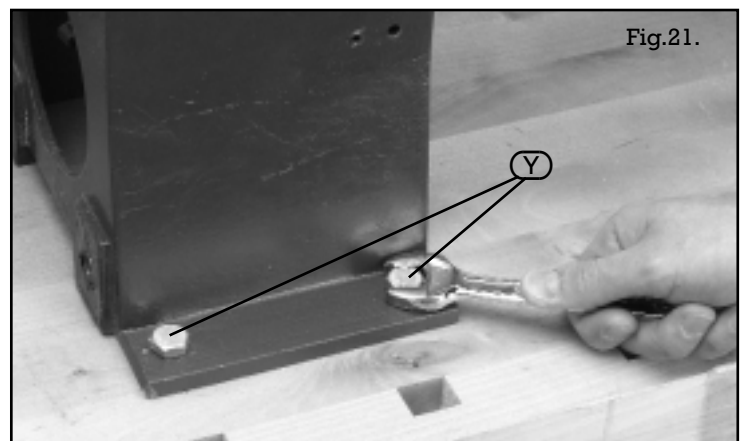

Now mark the two drill holes in the workbench/stand through the bed bar foot fixing holes (Z) as shown in Fig.22.

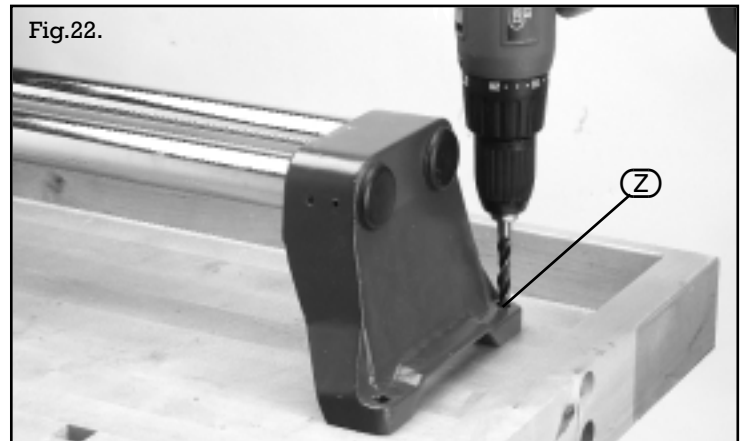

Insert one bolt into each of the holes. Now place a flat washer and nut onto each of the bolts and tighten. See Fig.23.



We recommend the switch and cable are mounted on the side of the workbench or on the leg of the wood lathe stand (optional accessory)(Fig.24A & B). This will ensure the cable is not pulled up into the workings when the headstock is rotated for spinning up larger pieces of work. Once a safe position is found the holes should be marked and drilled. Secure the switch box to the stand with suitable fixings (A) (not supplied) as shown.

Note: Make sure the switch is easily accessible in the event of an emergency.

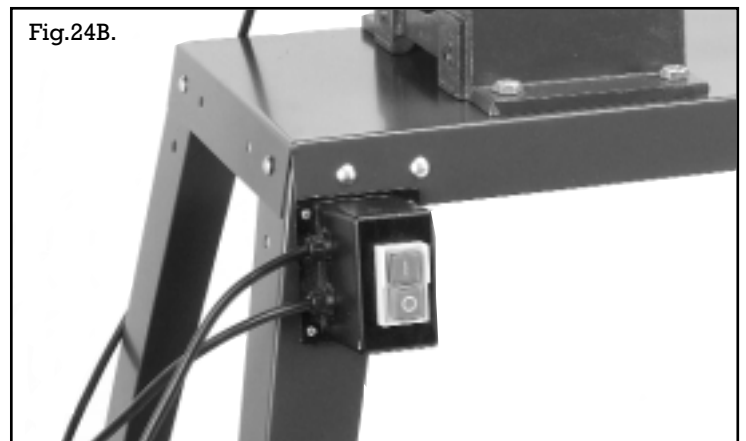
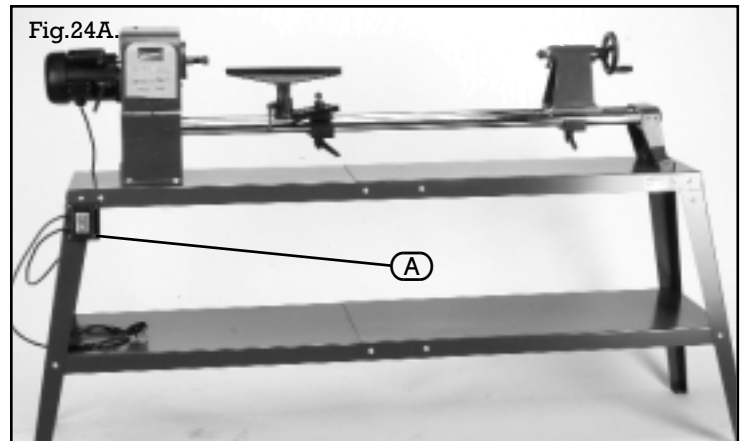

## CHANGING SPEEDS

Fig.25 shows the belt on the outside end of the pulleys. In this position the spindle will turn at maximum rpm, should you want to run the lathe at a slower speed, you must move the belt inwards.

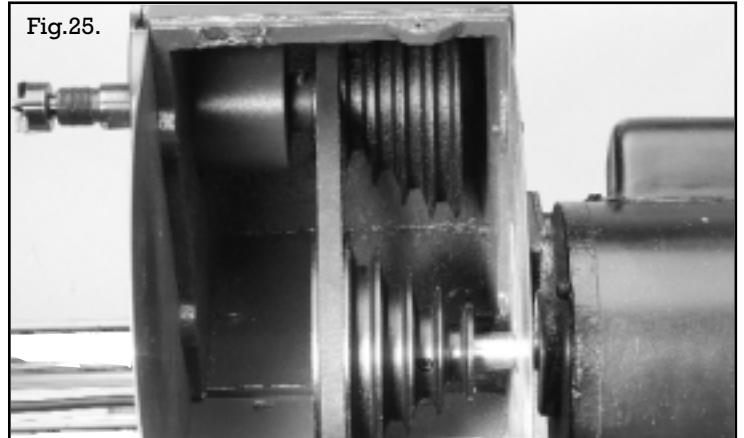

**IMPORTANT:-** Ensure the wood lathe is disconnected from the power supply before making any adjustments. If you want to increase the speed move the belt outwards. The drive belt can be moved as follows:

Release the motor locking handle (B) Fig.26.

Move the motor inwards, move belt to the required position, retension belt by moving motor outwards then tighten locking handle (B).

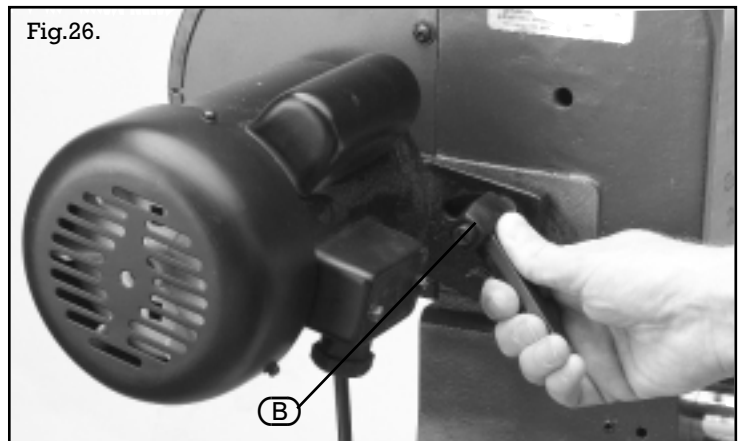

## HEADSTOCK POSITION ADJUSTMENT

The headstock assembly has three preset positions these are shown in Figs.27, 28 and 29. To move the headstock release locking lever (C) Fig.30 and turn the head in a clockwise direction until the head is in the required position then tighten locking lever (C) Fig.30.

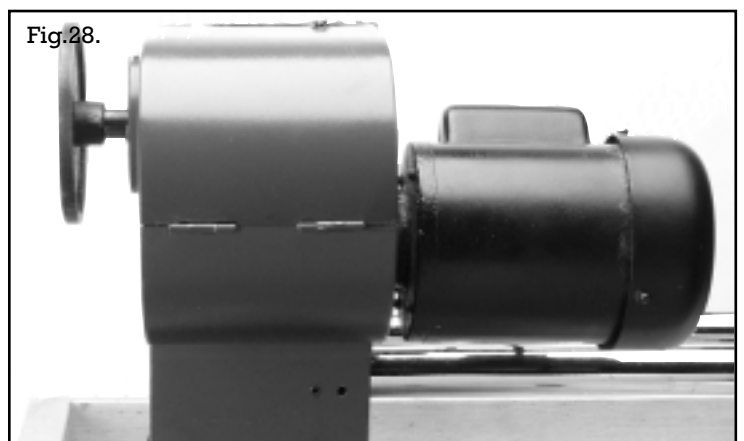

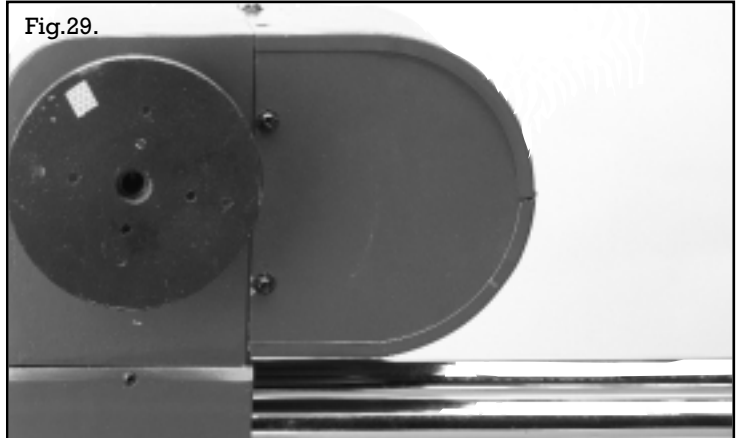

## CUP CENTRE ADJUSTMENT

The cup centre located in the tailstock barrel (D) supports the workpiece when spindle turning. The cup centre barrel may be adjusted as follows: Release locking handle (E) and turn the handwheel clockwise to decrease the distance between the centres, and turn the handwheel anticlockwise to increase the distance between the centres (Fig.31).

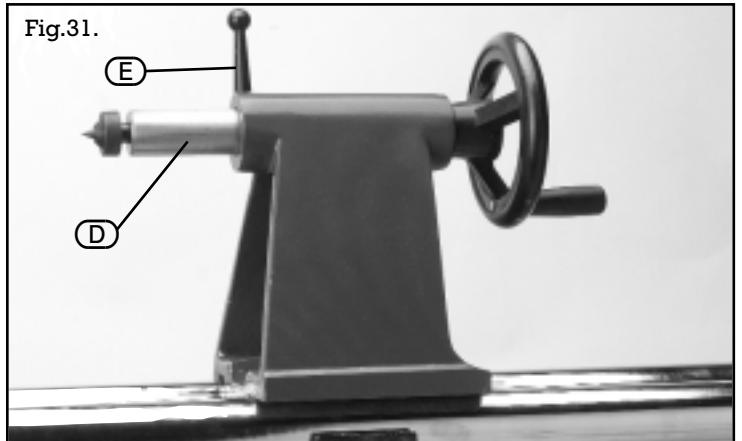

Once in position secure in place by tightening lock knob (E). The tailstock assembly can be moved to any part of the bed bars, loosen locking lever (F) (Fig.32), move to the required position and retighten.

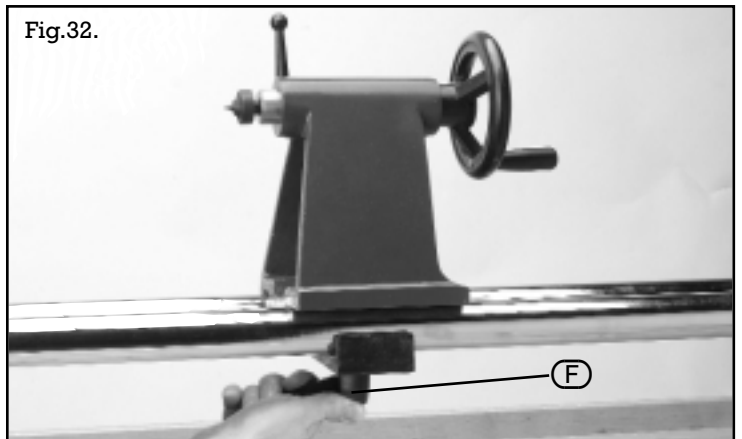

## TOOL REST ADJUSTMENT

The following adjustments can be made to the tool rest assembly:

**Height** - The height of the tool rest can be adjusted by loosening locking lever (G) Fig.33 moving the tool rest to the required height and tightening the locking lever.

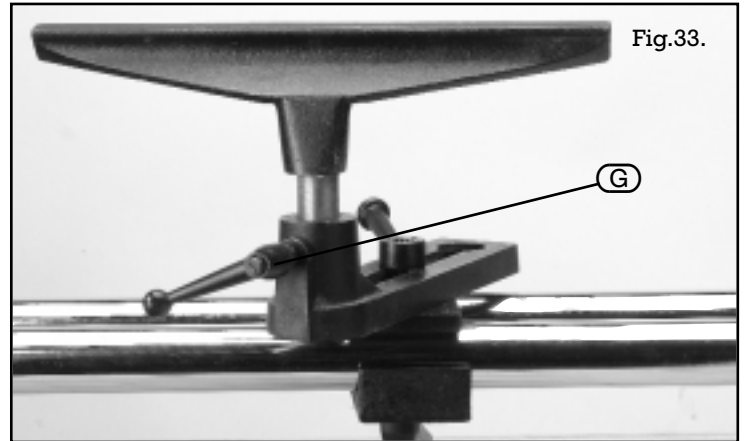

**Positioning - (length)**- The tool rest assembly can be moved along the length of the bed bar assembly. Loosen locking lever (H) Fig.34 move to the required position and retighten.

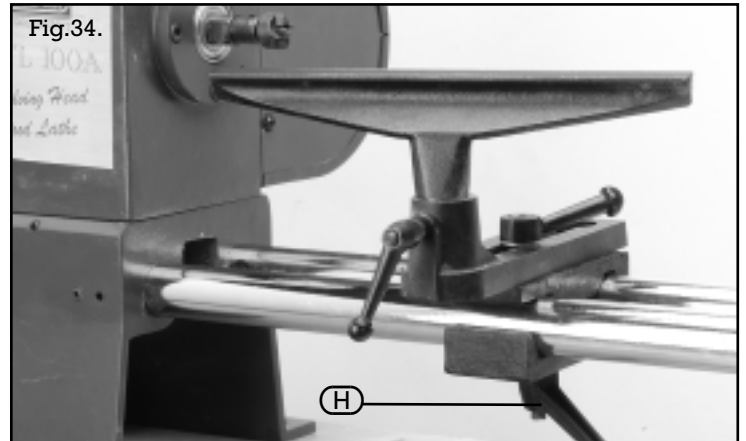

**Positioning - (width)**- The tool rest can be closer or further away from the workpiece as required. Loosen lever (I) Fig.35 move to the required position and retighten lever.

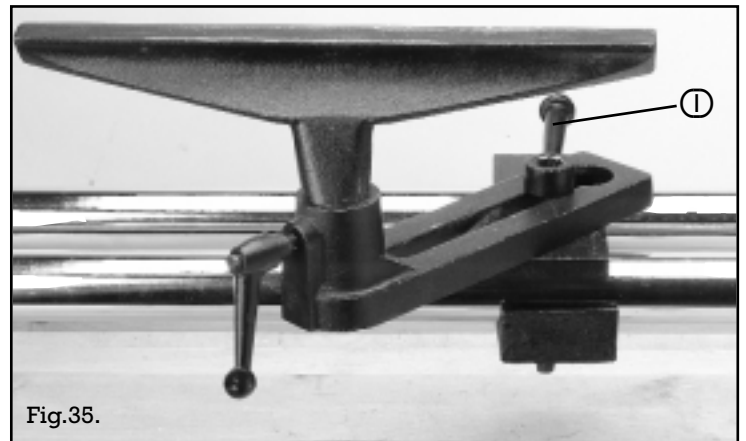

**Mounting woodstock onto a faceplate:** there are several ways in which you can mount the stock onto a conventional face plate, the most common way used is shown in Fig.36.

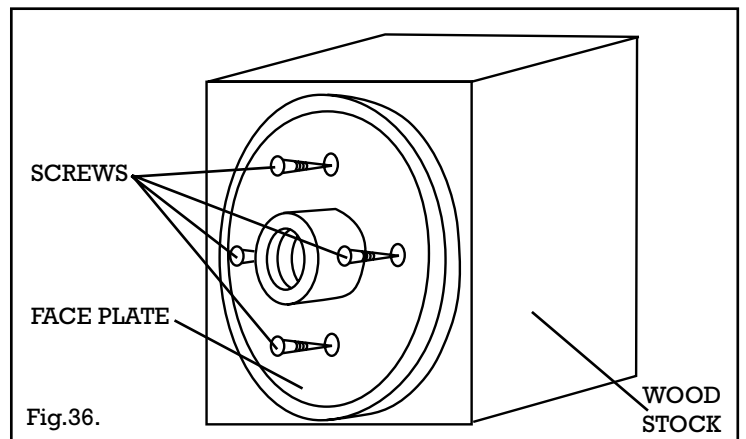



# TROUBLESHOOTING

**WARNING:**  
**FOR YOUR SAFETY ALWAYS TURN THE MAIN SWITCH ON THE MACHINE 'OFF' AND REMOVE THE PLUG FROM THE POWER SUPPLY BEFORE CARRYING OUT ANY MAINTENANCE OR TROUBLESHOOTING**

TROUBLE	PROBABLE CAUSE	REMEDY
Motor will not run.	1. Defective On-Off switch. Defective switch cord. 2. Burned out motor.	1. Replace defective parts before using Lathe. 2. Any attempt to repair this motor may cause a HAZARD unless repair is done by a qualified service technician.
Lathe slows down.	1. V-belt too loose.	1. Adjust belt tension, see Basic Lathe Operations
Wood burns at tailstock end.	1. Live centre too tight or not lubricated.	1. Back off tailstock barrel and lubricate live centre

# OPTIONAL ACCESSORIES

Wood Lathe Stand  
 Stock No.63196  
 Part No.AWL18

Combination Chuck  
 Stock No.37168  
 Part No.AWL40

Face Shield  
 Stock No.33831  
 Part No.FS8

A full range of wood turning accessories are shown in the Draper Catalogue.



# NOTES



# NOTES

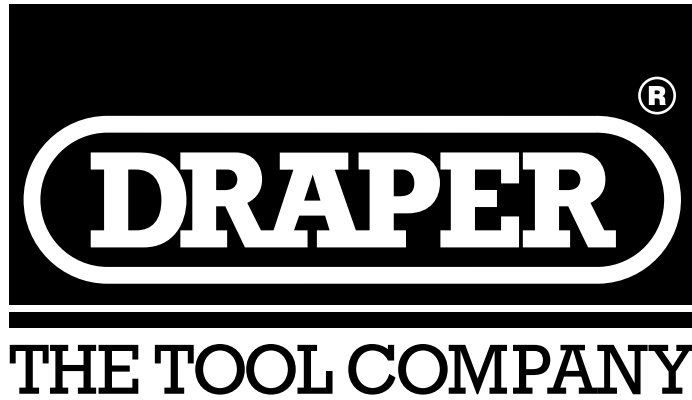

## **DRAPER TOOLS LTD.**

Hursley Road, Chandler's Ford,  
Eastleigh, Hants. SO53 1YF. England.

Tel: (023) 8026 6355.

Fax: (023) 8026 0784.

Helpline: (023) 8049 4344.



[www.draper.co.uk](http://www.draper.co.uk)

e-mail: [sales@draper.co.uk](mailto:sales@draper.co.uk)

YOUR DRAPER STOCKIST

©Published by Draper Tools Ltd.  
No part of this publication may be reproduced,  
stored in a retrieval system or transmitted in any  
form or by any means, electronic, mechanical  
photocopying, recording or otherwise without  
prior permission in writing from Draper Tools Ltd.