

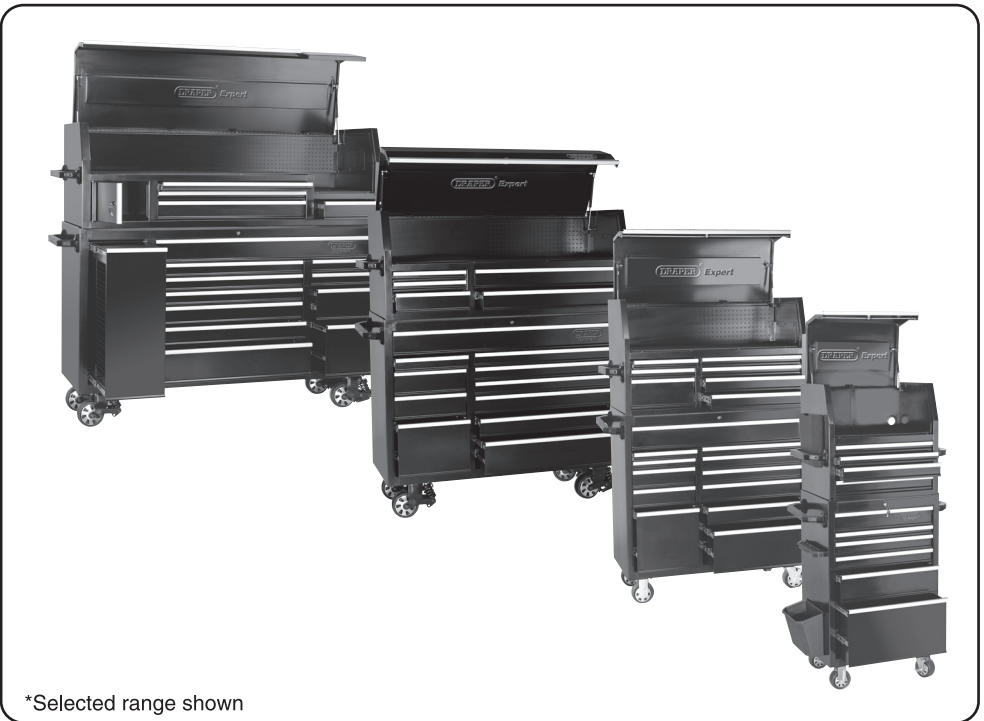

COMBINED TOOL CHESTS & ROLLER CABINETS

14213/14214/14215/14217/14252/14427/
14443/14444/14494/14527/14546/14580/
14583/14585/14586/14587/14588.

IMPORTANT: PLEASE READ THESE INSTRUCTIONS CAREFULLY TO ENSURE THE SAFE AND EFFECTIVE USE OF THIS PRODUCT.



*Selected range shown

INSTRUCTIONS

These instructions accompanying the product are the original instructions. This document is part of the product, keep it for the life of the product passing it on to any subsequent holder of the product. Read all these instructions before assembling, operating or maintaining this product.

This manual has been compiled by Draper Tools describing the purpose for which the product has been designed, and contains all the necessary information to ensure its correct and safe use. By following all the general safety instructions contained in this manual, it will ensure both product and operator safety, together with longer life of the product itself.

All photographs and drawings in this manual are supplied by Draper Tools to help illustrate the operation of the product.

Whilst every effort has been made to ensure the accuracy of information contained in this manual, the Draper Tools policy of continuous improvement determines the right to make modifications without prior warning.

1. SPECIFICATION

1.1 SCOPE

Manufactured from sheet steel with powder coated finish. Drawers are fitted with anti-slip mats and ball bearing runners for smoother operation and longer life. Each is fitted with a secure locking system and supplied with two keys.

2. HEALTH AND SAFETY INFORMATION

2.1 GENERAL SAFETY INFORMATION

- WEAR SAFETY GLASSES AND GLOVES when removing strapping and packaging materials. Straps can snap when removed causing personal injury.
- WEAR SAFETY GLASSES when replacing or repositioning ball bearing drawer slides.
- DO NOT pull this product-push the product to prevent personal injury.
- Swivel castor and push bar must be placed on same side of the product.
- USE THE BRAKE when this product is not being moved. The brake will prevent accidental rolling which may product damage or personal injury.
- DO NOT open more than one drawer at a time as this may cause the product to tip causing personal injury or product damage.
- DO NOT alter this product by welding attachment or adding electrical equipment. Do not mount this product on a moving object or vehicle as this may cause personal injury or product damage.
- DO NOT tow this product with moving equipment or vehicles as this may cause product to tip, causing personal injury or product damage.
- DO NOT step in drawers or on top of unit as this may cause the product to tip. This may cause personal injury or product damage.
- Take caution when closing the cover and remove hands before cover is closed completely.
- To lock a chest, close drawers before closing lid, making sure all drawers are firmly closed to ensure proper function of locking bars.
- Always use the proper sized cabinet and chest combination. Improper matching of cabinet and chest components can cause the product to tip which may result in personal injury or product damage.
- DO NOT use the product on uneven surfaces or inclines as this may cause the product to tip or become unstable resulting in possible personal injury or product damage.
- Remove work surface (if provided) before mounting top chest. If work surface is not removed, the top chest may slide off cabinet causing personal injury or product damage.

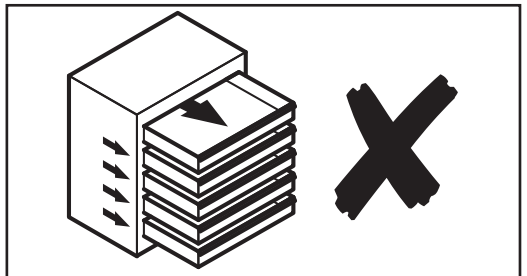
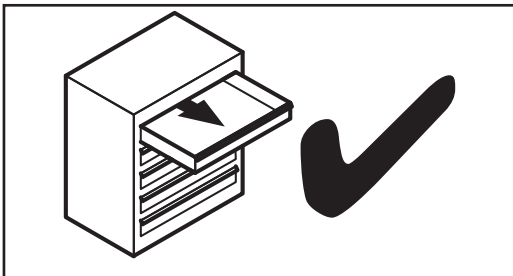

3. PREPARING THE TOOL CHEST

3.1 PUSH BAR ATTACHMENT (ROLLER CABINETS ONLY)

Note: Holes in the unit are taped requiring no nuts for installation.

Attach the handle using four screws supplied. Do not overtighten.



3.2 LOCK TOOL CHEST/ROLLER CABINET

Insure all drawers are fully closed. Insert key to lock.

Warning: DO NOT slam the drawers as the lock tabs (1) or pockets (2) at the back of the drawers will be damaged.

Should damage occur, the drawers will need to be removed to gain access to the tabs at the back of the cabinet (see draw removal section).

The pockets are on the back of the drawers and are easier to get to, check for damage.

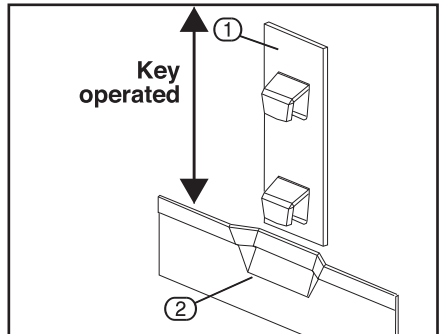

3.3 REMOVING AND INSTALLING DRAWERS

Ball bearing drawer slides have retaining clips. To remove the drawer, the retaining clips need to be released.

With the right hand lift the lever, with the left hand push down the lever; then at the same time pull the drawer out.

To re-install the drawer, align the bearing runner into the slider and push the drawer back fully. The clips will click into place as the drawer is pushed in.

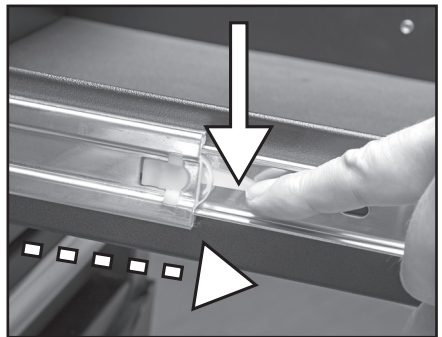

3.4 LUBRICATION

To ensure smooth operation of the sliders, lubricate periodically with a light grease. Do this at least twice a year.



3.5 CASTORS (ROLLER CABINETS ONLY)

The roller cabinet is supplied with four heavy duty castors, including two swivel castors with brakes. Carefully lie the cabinet on its back to gain access to the underside and attach the castors.

The side handle must be fixed on the same side as the swivel castors.

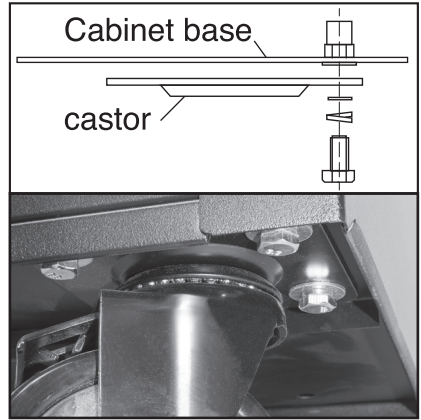

CONTACTS

Draper Tools Limited, Hursley Road,
Chandler's Ford, Eastleigh, Hampshire. SO53 1YF. U.K.

Helpline: (023) 8049 4344

Sales Desk: (023) 8049 4333

Internet: drapertools.com

E-mail: sales@drapertools.com

General Enquiries: (023) 8026 6355

Service/Warranty Repair Agent:

For aftersales servicing or warranty repairs, please contact the Draper Tools Helpline for details of an agent in your local area.

YOUR DRAPER STOCKIST

RWKC0718

©Published by Draper Tools Limited.

No part of this publication may be reproduced, stored in a retrieval system or transmitted in any form or by any means, electronic, mechanical photocopying, recording or otherwise without prior permission in writing from Draper Tools Ltd.