



**DRAPER**<sup>®</sup>

**STORMFORCE**

# 10.8V RECIPROCATING SAW

17129



These instructions accompanying the product are the original instructions. This document is part of the product, keep it for the life of the product passing it on to any subsequent holder of the product. Read all these instructions before assembling, operating or maintaining this product.

This manual has been compiled by Draper Tools describing the purpose for which the product has been designed, and contains all the necessary information to ensure its correct and safe use. By following all the general safety instructions contained in this manual, it will ensure both product and operator safety, together with longer life of the product itself.

All photographs and drawings in this manual are supplied by Draper Tools to help illustrate the operation of the product.

Whilst every effort has been made to ensure the accuracy of information contained in this manual, the Draper Tools policy of continuous improvement determines the right to make modifications without prior warning.

# 1. TITLE PAGE

---

## 1.1 INTRODUCTION:

**USER MANUAL FOR: 10.8V Reciprocating Saw**

**Stock No:17129**

**Part No:SS108SF**

## 1.2 REVISIONS:

---

**Date first published April 2019.**

---

---

---

---

As our user manuals are continually updated, users should make sure that they use the very latest version.

**Downloads are available from:** <http://drapertools.com/manuals>

Draper Tools Limited  
Hursley Road  
Chandler's Ford  
Eastleigh  
Hampshire  
SO53 1YF  
UK

**Website:** [drapertools.com](http://drapertools.com)

**Product Helpline:** +44 (0) 23 8049 4344

**General Fax:** +44 (0) 23 8026 0784

## 1.3 UNDERSTANDING THIS MANUALS SAFETY CONTENT:

**WARNING!** – Information that draws attention to the risk of injury or death.

**CAUTION!** – Information that draws attention to the risk of damage to the product or surroundings.

## 1.4 COPYRIGHT © NOTICE:

Copyright © Draper Tools Limited.

Permission is granted to reproduce this publication for personal and educational use only. Commercial copying, redistribution, hiring or lending is prohibited.

No part of this publication may be stored in a retrieval system or transmitted in any other form or means without written permission from Draper Tools Limited.

In all cases this copyright notice must remain intact.

---





## 2. CONTENTS

---

<b>1. TITLE PAGE</b>	
1.1 INTRODUCTION.....	2
1.2 REVISION HISTORY .....	2
1.3 UNDERSTANDING THIS MANUAL .....	2
1.4 COPYRIGHT NOTICE .....	2
<b>2. CONTENTS</b>	
2.1 CONTENTS.....	3
<b>3. WARRANTY</b>	
3.1 WARRANTY.....	4
<b>4. INTRODUCTION</b>	
4.1 SCOPE.....	5
4.2 SPECIFICATION .....	5
4.3 HANDLING & STORAGE.....	6
<b>5. HEALTH AND SAFETY INFORMATION</b>	
5.1 GENERAL POWER TOOL SAFETY WARNINGS.....	7-8
5.2 SAFETY INSTRUCTIONS FOR RECIPROCATING SAWS.....	8-9
5.3 RESIDUAL RISK .....	9
5.4 SAFETY INSTRUCTIONS FOR MAINS POWERED CHARGERS & BATTERY PACKS .....	9-10
5.5 CONNECTION TO THE POWER SUPPLY (CHARGER) .....	11
<b>6. TECHNICAL DESCRIPTION</b>	
6.1 IDENTIFICATION.....	12
<b>7. UNPACKING AND CHECKING</b>	
7.1 PACKAGING .....	13
7.2 DRAPER 10.8V MULTI-TOOL INTERCHANGEABLE BATTERY SYSTEM .....	13
7.3 WHAT'S IN THE BOX.....	13
<b>8. PREPARING THE RECIPROCATING SAW</b>	
8.1 BATTERY CHARGING.....	14
<b>9. BASIC RECIPROCATING SAW OPERATIONS</b>	
9.1 BLADE INSTALLATION.....	15
9.2 SWITCH AND VARIABLE STROKE RATE CONTROL.....	16
9.3 GENERAL CUTTING .....	16
9.4 FLUSH CUTTING.....	17
9.5 GENERAL CUTTING .....	17
<b>10. MAINTENANCE AND TROUBLESHOOTING</b>	
10.1 MAINTENANCE .....	18
10.2 TROUBLESHOOTING .....	18
<b>11. OPTIONAL ACCESSORIES</b>	
11.1 OPTIONAL ACCESSORIES.....	18
<b>12. DISPOSAL</b>	
12.1 DISPOSAL.....	19
<b>13. EXPLANATION OF SYMBOLS</b>	
13.1 EXPLANATION OF SYMBOLS .....	20
<b>DECLARATION OF CONFORMITY .....</b>	<b>ENCLOSED</b>

## 3. WARRANTY

---

### 3.1 WARRANTY

Draper tools have been carefully tested and inspected before shipment and are guaranteed to be free from defective materials and workmanship.

Should the tool develop a fault, please return the complete tool to your nearest distributor or contact:

**Draper Tools Limited, Chandler's Ford, Eastleigh, Hampshire, SO53 1YF. England.**

**Telephone Sales Desk: (023) 8049 4333** or:

**Product Helpline (023) 8049 4344.**

A proof of purchase must be provided.

If upon inspection it is found that the fault occurring is due to defective materials or workmanship, repairs will be carried out free of charge. This warranty period covering labour is 12 months from the date of purchase except where tools are hired out when the warranty period is 90 days from the date of purchase. The warranty is extended to 24 months from the date of purchase for parts only. This warranty does not apply to any consumable parts, any type of battery or normal wear and tear, nor does it cover any damage caused by misuse, careless or unsafe handling, alterations, accidents, or repairs attempted or made by any personnel other than the authorised Draper warranty repair agent.

Note: If the tool is found not to be within the terms of warranty, repairs and carriage charges will be quoted and made accordingly.

This warranty applies in lieu of any other warranty expressed or implied and variations of its terms are not authorised.

Your Draper warranty is not effective unless you can produce upon request a dated receipt or invoice to verify your proof of purchase within the warranty period.

Please note that this warranty is an additional benefit and does not affect your statutory rights.

**Draper Tools Limited.**



# 13. EXPLANATION OF SYMBOLS

## 13.1 EXPLANATION OF SYMBOLS



Read the instruction manual.



Wear face mask and safety glasses.



Wear ear defenders.



Wear protective gloves.



Long and loose hair must be contained or securely tied back.



Do not abandon into the environment.



Keep out of the reach of children.



**Warning!**



Single value noise marking.  
*(Maximum declared A-Weighted sound power level in decibels).*



Class II construction  
*(Double insulated).*



WEEE –  
Waste Electrical &  
Electronic Equipment.  
*Do not dispose of Waste Electrical & Electronic Equipment in with domestic rubbish.*



Lithium-ion product.

**Li-ion**



Do not incinerate or throw onto fire.



For indoor use only.  
Do not expose to rain.



Fuse.

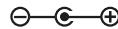

Polarity indication.



Rated voltage.



# 4. INTRODUCTION

---

## 4.1 SCOPE

This reciprocating saw is designed to cut wood, plastic and metal, including sheet materials, branches/logs and window surrounds.

This product is intended for domestic and infrequent light trade use only. Any application other than that it was intended for, is considered misuse.

## 4.2 SPECIFICATION

Stock No. ....	17129
Part No. ....	SS108SF
Cutting capacities:	
Wood .....	65mm
Plastic .....	50m
Steel .....	8mm
Stroke length .....	14.5mm
Strokes per minute (no load) .....	0-3000s/min
Sound pressure level (LpA)*: .....	83.58dB(A)
Sound power level (LWA)**: .....	94.58dB(A)
Uncertainty (K): .....	3dB(A)
Vibration level cutting boards with a saw blade:.....	13.78m/s <sup>2</sup> , K=1.5m/s <sup>2</sup>
Weight (machine only):.....	1.1kg

*†When sawing in wood.*

Battery pack (16254 sold separately):

Part No. ....	CB108LI
Type .....	Li-ion
Rated Voltage .....	10.8V
Rating .....	1.5Ah

Charger (16255 sold separately):

Part No. ....	C108LI
Rated Voltage .....	230V~
Rated Frequency .....	50Hz
Rated D.C. output voltage .....	10.8V
Rated D.C. output current .....	2.0A
Protective device rated current .....	2A
Construction .....	Class II

\* *Continuous A-Weighted Sound Pressure Level at the workstation in accordance to and declared according to EN60745.*

\*\* *The typical A-weighted noise level determined according to EN60745.*

## 4. INTRODUCTION

---

### 4.3 HANDLING & STORAGE

- Care must be taken when handling this product.
  - Dropping this power tool could have an effect on its accuracy and could also result in personal injury. This product is not a toy and must be respected.
- Environmental conditions can have a detrimental effect on this product if neglected.
  - Exposure to damp air can gradually corrode components.
  - If the product is unprotected from dust and debris, components will become clogged.
  - If not cleaned and maintained correctly or regularly, the machine will not perform at its best.

# 12. DISPOSAL

---

## 12.1 DISPOSAL

- At the end of the machine's working life, or when it can no longer be repaired, ensure that it is disposed of according to national regulations.
- Contact your local authority for details of collection schemes in your area.

In all circumstances:

- Do not dispose of power tools with domestic waste.
- Do not incinerate.
- Do not dispose of WEEE\* as unsorted municipal waste.



\* Waste Electrical & Electronic Equipment.

## 12.2 BATTERY PACK DISPOSAL INFORMATION

### Warning!

- Do not put battery pack in fire or mutilate – cells may burst or release toxic materials.
- Do not short circuit cells, may cause burns.
- The battery pack must be removed from the appliance before it is scrapped.
- The battery pack is to be disposed of safely.
- Do not mutilate batteries, corrosive electrolyte will be released.
- Do not dispose of batteries or cells in a charged condition.

Expired batteries must be recycled/disposed of in accordance with the appropriate regulation or legislation. They should be returned to your local warranty agent/stockist.

# 10. MAINTENANCE AND TROUBLESHOOTING

---

## 10.1 MAINTENANCE

Regular inspection and cleaning reduces the necessity for maintenance operations and will keep your tool in good working condition.

The motor must be correctly ventilated during tool operation. Avoid blocking the air inlets and vacuum the ventilation slots regularly.

## 10.2 TROUBLESHOOTING

Problem	Possible Cause	Remedy
Saw does not work.	1. Flat battery.	1. Re-charge battery.
Blade does not locate.	1. Check blade retaining mechanism. 2. Swarf in retaining mechanism.	1. Remove blade, fully open retaining mechanism and re-insert blade. 2. Clean inside retaining mechanism with cleaning fluid.

# 11. OPTIONAL ACCESSORIES

---

## 11.1 OPTIONAL ACCESSORIES

A full range of blades are available from Draper Tools.

Please visit our website for details: [www.drapertools.com](http://www.drapertools.com)

## 5. HEALTH AND SAFETY INFORMATION

---

### Power tool use and care

**Do not force the power tool. Use the correct power tool for your application.** *The correct power tool will do the job better and safer at the rate for which it was designed.*

**Do not use the power tool if the switch does not turn it on and off.** *Any power tool that cannot be controlled with the switch is dangerous and must be repaired.*

**Disconnect the plug from the power source and/or remove the battery pack, if detachable, from the power tool before making any adjustments, changing accessories, or storing power tools.** *Such preventive safety measures reduce the risk of starting the power tool accidentally.*

**Store idle power tools out of the reach of children and do not allow persons unfamiliar with the power tool or these instructions to operate the power tool.** *Power tools are dangerous in the hands of untrained users.*

**Maintain power tools and accessories. Check for misalignment or binding of moving parts, breakage of parts and any other condition that may affect the power tool's operation. If damaged, have the power tool repaired before use.** *Many accidents are caused by poorly maintained power tools.*

**Keep cutting tools sharp and clean.** *Properly maintained cutting tools with sharp cutting edges are less likely to bind and are easier to control.*

**Use the power tool, accessories and tool bits etc. in accordance with these instructions, taking into account the working conditions and the work to be performed.** *Use of the power tool for operations different from those intended could result in a hazardous situation.*

**Keep handles and grasping surfaces dry, clean and free from oil and grease.** *Slippery handles and grasping surfaces do not allow for safe handling and control of the tool in unexpected situations.*

### Service

**Have your power tool serviced by a qualified repair person using only identical replacement parts.** *This will ensure that the safety of the power tool is maintained.*

## 5.2 SAFETY INSTRUCTIONS FOR RECIPROCATING SAWS

- Hold the power tool by insulated gripping surfaces, when performing an operation where the cutting accessory may contact hidden wiring or its own cord. Cutting accessory contacting a "live" wire may make exposed metal parts of the power tool "live" and could give the operator an electric shock.
- Use clamps or another practical way to secure and support the workpiece to a stable platform. Holding the workpiece by hand or against your body leaves it unstable and may lead to loss of control.

### CHANGING BLADES

- Ensure the saw is unplugged before changing blades, and take care to prevent entrapment of the fingers between the blade and the shoe. Ensure the blade is secure before use.
- Use the appropriate blade for the material being cut. Different blades are available from your Draper stockist.
- Only use blades in perfect working condition. Discard and replace any cracked or bent saw blades.

### WHEN SAWING

- Use of the mains cable. Ensure the mains cable is kept well away from the saw blade and ensure an adequate electrical supply is close at hand so that the operation is not restricted by the length of the cable.
- Allow sufficient clearance beneath the work to ensure the blade does not come into contact with the floor, bench etc.
- Switching off. Never place the saw on a table or bench if it has not completely stopped. The

## 9. BASIC RECIPROCATING SAW OPERATIONS

### 9.4 FLUSH CUTTING – FIG.8

With the use of flexible bimetal saw blades, projecting items (i.e. water pipes, etc.) can be sawn off flush to the wall. Pay attention that the saw blade always extends beyond the diameter of the pipe being sawn. Danger of kickback.

Position the saw blade sideways against the wall and apply some lateral pressure via the tool so the edge of the pivoting sole plate faces against the wall. Switch the tool on and make the cut, applying constant lateral pressure.

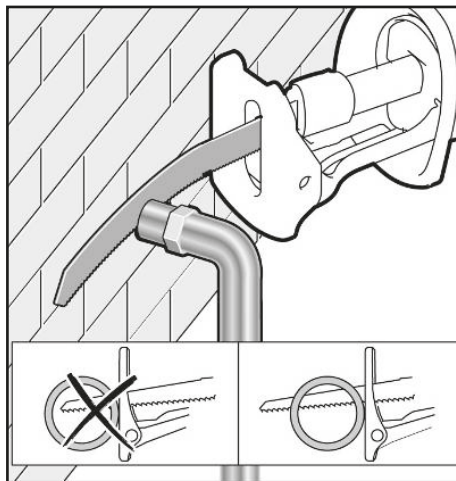

FIG.8

### 9.5 GENERAL CUTTING

**Warning!** Before use, always check to see that the trigger is actuated properly and returns to the off position when released.

**Warning!** When sawing into walls or floors you may encounter electrical wiring. Sawing into a “live” wire will cause electric shock. Always check with a metal/voltage detector that there are no hidden hazards such as electrical cables, water or gas pipes running below the surface.

- Make sure the workpiece is firmly anchored. Clamp the workpiece to prevent slipping or moving while cutting.
- Use the appropriate type and size of blade for the workpiece material and size.
- Check for clearance beyond the workpiece so the blade will not impact another surface.
- Mark the line of cut clearly. If cutting metal, apply cutting oil on the line.
- Depress the trigger switch to start the saw and bring it to maximum desired cutting stroke rate before applying the blade to the workpiece.
- Do not force the tool. Place the sole plate firmly on the workpiece while cutting. Use only enough steady pressure on the blade to keep the saw cutting. Reduce pressure as the blade comes to the end of the cut.
- Cutting stroke rates should vary with the workpiece. Hard materials such as metals require lower stroke rates, for softer materials use higher stroke rates.
- Check wood, chip boards, building materials etc. for foreign objects (nails, screws, etc.) before sawing and remove them, if necessary.
- Position the pivoting sole plate onto the surface of the work and saw through the work applying uniform contact pressure of feed.

If the saw blade jams, switch off the tool immediately. Widen the saw cut with a suitable tool and pull out the saw blade.

# 9. BASIC RECIPROCATING SAW OPERATIONS

## 9.2 SWITCH AND VARIABLE STROKE RATE CONTROL - FIG. 5

Your reciprocating saw is equipped with a safety lock and a trigger switch to turn the saw on and off, and to control the speed.

- To start the saw, ensure that the safetylock is pushed towards the body of the tool from the “unlocked lock” decal on the side of the switch, press the trigger switch ⑦.
- To stop the saw, release the trigger switch.
- To vary the stroke rate, simply increase or decrease the pressure on the trigger switch. The tighter the trigger switch is pressed, the higher the speed.



FIG.5

## 9.3 GENERAL CUTTING

**Warning:** Before use, always check to see that the trigger is actuated properly and returns to the off position when released.

**Warning:** When sawing into walls or floors you may encounter electrical wiring. Sawing into a “live” wire will cause electric shock. Always check with a metal/voltage detector that there are no hidden hazards such as electrical cables, water or gas pipes running below the surface.

- Make sure the workpiece is firmly anchored. Clamp the workpiece to prevent slipping or moving while cutting.
- Use the appropriate type and size of blade for the workpiece material and size.
- Check for clearance beyond the workpiece so the blade will not impact another surface.
- Mark the line of cut clearly. If cutting metal, apply cutting oil on the line.
- Depress the trigger switch to start the saw and bring it to maximum desired cutting stroke rate before applying the blade to the workpiece.
- Do not force the tool. Place the shoe firmly on the workpiece while cutting. Use only enough steady pressure on the blade to keep the saw cutting. Reduce pressure as the blade comes to the end of the cut.
- Cutting stroke rates should vary with the workpiece. Hard materials such as metals require lower stroke rates, for softer materials use higher stroke rates.
- Check wood, chip boards, building materials etc. for foreign objects (nails, screws, etc.) before sawing and remove them, if necessary.
- Position the pivoting footplate onto the surface of the work and saw through the work applying uniform contact pressure of feed.

If the saw blade jams, switch off the tool immediately. Widen the saw cut with a suitable tool and pull out the saw blade.

## 5. HEALTH AND SAFETY INFORMATION

---

saw blade will continue to operate for a short time after the trigger has been released to stop the saw.

- Cutting of pipes. Use caution when cutting hollow pipe and do not cut material where the blade can enter the pipe when fully retracted, this can cause the blade to strike the inside of the pipe causing the user to experience unexpected reaction forces.
- Cutting into walls. Do not cut through walls or cavities without checking for hidden electrical wires or water pipes etc.
- Do not attempt to remove tool from work until the blade has completely stopped and allow time for it to cool before touching the blade immediately after use.
- Use clamps and vices to secure the workpiece where possible.
- Cutting sheet materials. Do not cut material less than at least twice the pitch of the saw blade. At least two teeth must be in contact with the work at all times.
- Beware of foreign objects. When cutting pre-used wood, ensure all nails have been removed beforehand. Nails will damage the wood saw blade.
- Cooling agents. When cutting metals, always use a cooling agent i.e. cutting/soluble oil.
- Do not attempt to saw small objects including those which cannot be properly secured. Always hold the saw with both hands.

### 5.3 RESIDUAL RISK

**Important:** Although the safety instructions and operating manuals for our tools contain extensive instructions of safe working with power tools, every power tool involves a certain residual risk which

can not be completely excluded by safety mechanisms. Power tools must therefore always be operated with caution!

### 5.4 SAFETY INSTRUCTIONS FOR MAINS POWERED CHARGERS & BATTERY PACKS

#### Chargers

- The charger is for indoor use only.
- Prior to plugging the charger in to the supply, check that the plug and the cable are in good repair. If either are damaged, have the defective item replaced immediately by a suitably qualified person. If the casing of the battery charger is damaged, it is good policy to have the charger checked over by a suitably qualified person.
- Only use a correctly rated mains outlet to provide power, do not plug into site generators, attach to engine generators or D.C. sources. Do not use a mains socket outlet that is not switched.
- Use the correct Draper charger in conjunction with it's corresponding battery pack (consult the Draper website for more information or to find your local stockist).
- Do not charge any other batteries with Draper chargers. Any other application is considered misuse.
- Do not attempt to charge battery packs that are too hot (over 30°C) or too cold (under 5°C), if these conditions apply set the battery pack aside to "normalise" before proceeding with the charging operation.
- Set up the charger and cable in a safe place where it won't be knocked, tripped over, stepped on, etc. and where it is well ventilated. Make sure the ventilation slots in the charger case are not obstructed, plug the charger into the socket outlet.
- Inspect the battery pack for damage, if it is undamaged, plug it into the charger, ensuring the correct orientation. (Most chargers and batteries have 'keys' etc, to make sure the battery pack is not inserted incorrectly, if you are having to 'force' the battery pack into the charger, the chances are you have it the wrong way round, check and try again.)
- Switch the charger on and check that the correct indicators illuminate, allow the battery pack to



## 5. HEALTH AND SAFETY INFORMATION

---

charge (see the specific instructions for your charger). Once charging is complete, switch the charger off, remove the battery pack and store, repeat the procedure if you have more than one battery pack to charge.

**Caution:** When the battery charger has been continuously used, the battery charger will be hot. Once the charging has been completed, give 15 minutes rest until the next charge.

- After charging is complete, unplug the charger from the socket outlet by pulling on the plug. Do not pull on the cable. Store the charger in a dry secure place.
- If, when the charger was switched on, the correct indications did not occur, leave for two or three minutes to allow the charger to stabilise, if the correct indications occur, allow the charging cycle to proceed as normal. If no indication appears at all, switch off, remove the battery pack, unplug the charger, check that the charger contacts and the battery contacts are clean and repeat the process. If there is still no indication, switch off, remove the battery pack, unplug the charger and check the fuse. If the fuse is blown, replace and repeat the process. If the fuse blows again, or if the fuse was intact, attempt no further action. Refer the charger to a suitably qualified person for repair.

### **Battery packs**

- Before charging, read the instructions.
- For indoor use. Do not expose to rain.
- Only use Draper battery packs with this product. Consult your Draper stockist for details.
- Do not charge any other manufacturer's battery packs using Draper chargers. Any other application is considered misuse.
- The battery must be removed from the appliance before it is recycled.
- The charger must be disconnected from the supply mains when removing the battery.
- The battery is to be disposed of in-line with local authority procedures.
- Do not use any other than the designated Draper batteries/chargers with this product.
- Do not crush, open or burn the battery. Exposure to potentially harmful materials may occur.
- In case of fire use CO<sub>2</sub> or dry chemical extinguisher.
- Do not expose to high temperatures >50°C. The battery may degrade at high temperatures.
- Charge battery in conditions between 5°C to 30°C with the specified charger designed for this battery.
- Do not use battery if it has been stored at 5°C or less. Allow it to "normalise" at room temperature before usage/charging.

### **Warning!**

- Leaking battery packs
  - The electrolyte in battery packs is corrosive. Avoid contact with the skin.
  - If contact is made, flush the area with running water, pat dry and seek medical attention and advice at the earliest opportunity.
  - Inform medical personnel that the contaminant is a "high alkaline, corrosive liquid".
  - If electrolyte comes into contact with the eyes, flush with copious amounts of water only. Seek medical attention immediately, relaying the information above.

## 9. BASIC RECIPROCATING SAW OPERATIONS

---

### 9.1 BLADE INSTALLATION - FIGS. 1 - 2

Turn and hold the spring-loaded blade release clamp (2) counter-clockwise.

Insert the blade into the slot (2.1) of blade clamp (2).

Release the blade clamp to lock the blade.

Check that the blade is secure before operating the saw.

**Warning:** When changing a blade immediately after operation, allow the blade to cool before removing to avoid possible burning.

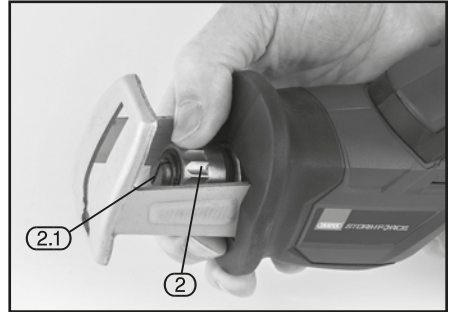

FIG.1



FIG.2

# 8. PREPARING THE RECIPROCATING SAW

## 8.1 BATTERY CHARGING - FIGS. 1 - 2

Check the mains voltage. Make sure the voltage of the power source is the same as the voltage specified on the rating plate of the charger unit.

Plug your mains plug into the power source. The green LED indicator (11.2) will blink indicating stand-by mode.

Insert battery pack into battery compartment of the charger. The red LED indicator will light solid. This indicates that the battery pack is being fast charged automatically.

When the battery pack is fully charged, the red LED indicator will turn off and the green LED will illuminate solid.

Remove the battery pack from the charger and unplug.

### IMPORTANT CHARGING NOTES:

Longest life and best performance can be obtained if the battery pack is charged when the surrounding air temperature is between 18°C (65°F) and 24°C (75°F). DO NOT charge battery pack in an air temperature below 4.5°C (40°F), or above 40.5°C (105°F). This is important and will prevent serious damage to the battery pack.

The charger is designed to fast charge the battery pack between 0°C (32°F) AND 45°C (113°F). If the battery pack, when inserted, is too cold or too hot, the charger will not charge. The green LED and the red LED will blink alternatively and continuously to indicate this situation. Once the air temperature is within tolerance, the fast charging will begin.

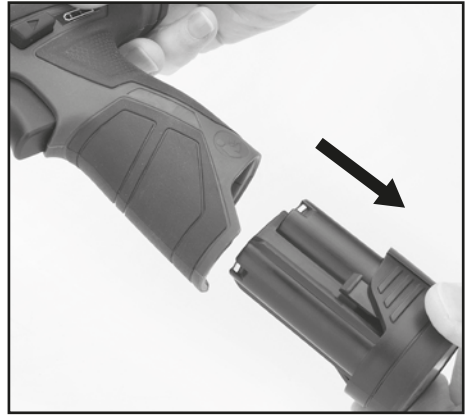

FIG.1

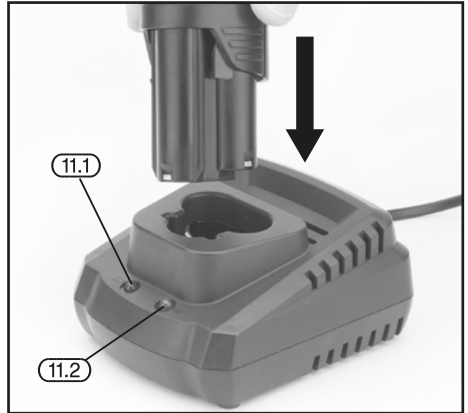

FIG.2

### Charger Light Indicator

LED Indicator		Situation
Green	Red	
Blinking light	No Light	Stand by.
No Light	Solid light	Charging.
Solid Light	No light	Charging is complete.
Blinking Light	Blinking Light	Battery pack is too hot or cold (charging will begin automatically when battery reaches correct charging temperature).
No light	Blinking Light	Damaged or faulty battery pack.

## 5. HEALTH AND SAFETY INFORMATION

---

### 5.5 CONNECTION TO THE POWER SUPPLY (CHARGER)

**Caution:** Risk of electric shock. Do not open.

This appliance is supplied with a moulded 3 pin mains plug for your safety. The value of the fuse fitted is marked on the pin face of the plug. Should the fuse need replacing, ensure the substitute is of the correct rating, approved to BS1362 and ASTA or BSI Kite marked.

ASTA 

BSI 

The fuse cover is removable with a small plain slot screwdriver. Ensure the fuse cover is replaced before attempting to connect the plug to an electrical outlet. If the cover is missing, a replacement must be obtained or the plug replaced with a suitable type.

If a replacement plug is to be fitted this must be carried out by a qualified electrician.

The damaged or incomplete plug, when cut from the cable should be disabled to prevent connection to a live electrical outlet.

This appliance is Class II† and is designed for connection to a power supply matching that detailed on the rating label and compatible with the plug fitted.

If an extension lead is required, use an approved and compatible lead rated for this appliance. Follow all the instructions supplied with the extension lead.

†*Double insulated* : *This product requires no earth connection as supplementary insulation is applied to the basic insulation to protect against electric shock in the event of failure of the basic insulation.*

#### **IMPORTANT**

**If using an extension lead, follow the instructions that came with your lead regarding maximum load while cable is wound. If in doubt, ensure that the entire cable is unwound. Using a coiled extension lead will generate heat which could melt the lead and cause a fire.**

## 6. TECHNICAL DESCRIPTION

### 6.1 IDENTIFICATION



- ① Foot
- ② Quick release blade clamp
- ③ Secondary hand grip
- ④ Battery charge indicator
- ⑤ Safety lock

- ⑥ Hand grip
- ⑦ Variable speed trigger
- ⑧ LED worklight

# 7. UNPACKING AND CHECKING

## 7.1 PACKAGING

Carefully remove the product from the packaging and examine it for any sign of damage that may have happened during shipping. Lay the contents out and check them against the parts shown below. If any part is damaged or missing, please contact the Draper Help Line (the telephone number appears on the Title page) and do not attempt to use the product.

The packaging material should be retained at least during the warranty period, in case the machine needs to be returned for repair.

### Warning!

- Some of the packaging materials used may be harmful to children. Do not leave any of these materials in the reach of children.
- If any of the packaging is to be thrown away, make sure they are disposed of correctly, according to local regulations.

## 7.2 DRAPER 10.8V MULTI-TOOL INTERCHANGEABLE BATTERY SYSTEM

This tool is supplied without a battery, and without a charger. These optional accessories are available.

The Draper 10.8V multi-tool interchange range features an array of machines all running from the same battery. To find out the latest range of accessories including battery and charger please consult the Draper website for more information or to find your local Draper stockist.



## 7.3 WHAT'S IN THE BOX

As well as the reciprocating saw, there are several parts not fitted or attached to it.

- ⑨ Metal cutting blade
- ⑩ Wood cutting blade

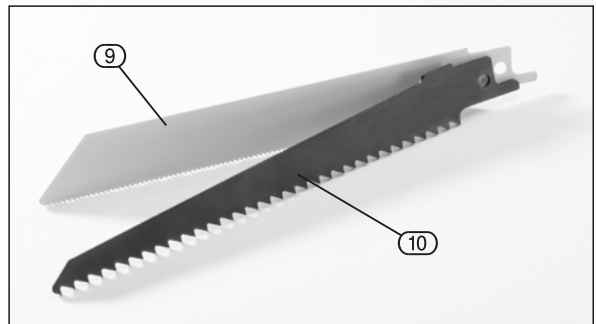

# CONTACTS

Draper Tools Limited, Hursley Road,  
Chandler's Ford, Eastleigh, Hampshire. SO53 1YF. U.K.

Helpline: (023) 8049 4344

Sales Desk: (023) 8049 4333

Internet: [drapertools.com](http://drapertools.com)

E-mail: [sales@drapertools.com](mailto:sales@drapertools.com)

General Enquiries: (023) 8026 6355

**Service/Warranty Repair Agent:**

For aftersales servicing or warranty repairs, please contact the Draper Tools Helpline for details of an agent in your local area.

## YOUR DRAPER STOCKIST

TAKC0419

©Published by Draper Tools Limited.

No part of this publication may be reproduced, stored in a retrieval system or transmitted in any form or by any means, electronic, mechanical photocopying, recording or otherwise without prior permission in writing from Draper Tools Ltd.