



DRAPER[®]

LIQUID COOLED

INDUCTION HEATING TOOL

76171

IMPORTANT: Read manual before use!!



CE

These instructions accompanying the product are the original instructions. This document is part of the product, keep it for the life of the product passing it on to any subsequent holder of the product. Read all these instructions before assembling, operating or maintaining this product.

This manual has been compiled by Draper Tools describing the purpose for which the product has been designed, and contains all the necessary information to ensure its correct and safe use. By following all the general safety instructions contained in this manual, it will ensure both product and operator safety, together with longer life of the product itself.

All photographs and drawings in this manual are supplied by Draper Tools to help illustrate the operation of the product.

Whilst every effort has been made to ensure the accuracy of information contained in this manual, the Draper Tools policy of continuous improvement determines the right to make modifications without prior warning.

1. TITLE PAGE

1.1 INTRODUCTION:

USER MANUAL FOR: Liquid Cooled Induction Heating Tool

Stock No: 76171

Part No: IHT-30

1.2 REVISIONS:

Date first published December 2017.

second published October 2019

As our user manuals are continually updated, users should make sure that they use the very latest version.

Downloads are available from: <http://drapertools.com/manuals>

Draper Tools Limited
Hursley Road
Chandler's Ford
Eastleigh
Hampshire
SO53 1YF
UK

Website: drapertools.com

Product Helpline: +44 (0) 23 8049 4344

General Fax: +44 (0) 23 8026 0784

1.3 UNDERSTANDING THIS MANUALS SAFETY CONTENT:

WARNING! – Information that draws attention to the risk of injury or death.

CAUTION! – Information that draws attention to the risk of damage to the product or surroundings.

1.4 COPYRIGHT © NOTICE:

Copyright © Draper Tools Limited.

Permission is granted to reproduce this publication for personal and educational use only. Commercial copying, redistribution, hiring or lending is prohibited.

No part of this publication may be stored in a retrieval system or transmitted in any other form or means without written permission from Draper Tools Limited.

In all cases this copyright notice must remain intact.

2. CONTENTS

1. TITLE PAGE	
1.1 INTRODUCTION.....	2
1.2 REVISION HISTORY	2
1.3 UNDERSTANDING THIS MANUAL	2
1.4 COPYRIGHT NOTICE	2
2. CONTENTS	
2.1 CONTENTS	3-4
3. GUARANTEE	
3.1 GUARANTEE	5
4. INTRODUCTION	
4.1 SCOPE	6
4.2 SPECIFICATION	6
4.3 HANDLING AND STORAGE	6
5. HEALTH AND SAFETY INFORMATION	
5.1 GENERAL RULES WHEN USING LIQUID COOLED INDUCTION HEATING TOOL ..	7
5.2 ELECTRIC SHOCK	7
5.3 CAUTION! HOT SURFACE	7
5.4 RISK OF FIRE	7
5.5 SAFETY EQUIPMENT WHEN WORKING WITH THE DEVICE	8
5.6 ELECTROMAGNETIC EFFECTS	8
5.7 CONNECTION TO THE POWER SUPPLY	8
6. TECHNICAL DESCRIPTION	
6.1 IDENTIFICATION.....	9
7. UNPACKING AND CHECKING	
7.1 PACKAGING	10
8. ASSEMBLING THE INDUCTION HEATING TOOL	
8.1 UNPACKING AND FIRST START	11
8.2 COOLANT REFILLING	11
8.3 SUPPORTED TECHNOLOGIES	
– 1) HCS3 - Heating Control System 3	12
– 2) BIPT – Boost Induction Power Technology	12
– 3) DIPA - Dynamic Induction Power Adjust.....	12
– 4) QST - Quiet Cooling Technology	12
– 5) URC - Universal Remote Control	12
– 6) ACMS - Automatic Check And Monitor System	12
– 7) DFU - Device Firmware Update	12
– 8) Field or Burner Power Mode (CF).....	12
– 9) Control power mode (CP).....	12
– 10) Controlled heating.....	13
8.4 REMOTE CONTROL AND INTEGRATION INTO PRODUCTION PROCESS	13

2. CONTENTS

9. INDUCTION HEATING TOOL INSTRUCTION

9.1	HEATING INDICATOR LAMP	14
9.2	ACTIVATING THE DEVICE	14
9.3	STANDBY	14-15
9.4	HEATING TIMER	15
9.5	INFO	
	- 1) P – Power transmitted	16
	- 2) Po – Output power	16
	- 3) PF – Power Factor	16
	- 4) Frequency “FrE”	17
	- 5) Output current	17
	- 6) Input current	17
	- 7) Input voltage	17
	- 8) Cooling temperature	17
	- 9) Limitation	17
	- 10) The heating is limited	17
	- 11) Errors	17
9.6	SETTING	
	- 1) The indicator lamp has to following statuses	18
	- 2) “HC” Heating mode	18
	- 3) “Po L” Maximum output power	18
	- 4) “ic.L” Power Line Current Limit	19
	- 5) “FIL” Coolant filling and venting	19
	- 6) “CoL” Cooling settings	19
	- 7) “RC” Remote control	19
	- 8) FAC “Factory setting”	19
	- 9) Firmware	19
	- 10) Unlock code	19
9.7	REMOTE CONTROL	19
9.8	REPLACEABLE HEATING INDUCTOR EXTENDERS	20
9.9	HEATING INDUCTOR HEAD REPLACEMENT PROCEDURE	20

10. MAINTENANCE & TROUBLESHOOTING

10.1	STORAGE	21
10.2	LIST OF ERROR MESSAGES	21
10.3	TECHNICAL PARAMETERS	22

11. EXPLANATION OF SYMBOLS

11.1	EXPLANATION OF SYMBOLS	23
------	------------------------------	----

12. DISPOSAL

12.1	DISPOSAL	24
------	----------------	----

DECLARATION OF CONFORMITY ENCLOSED

3. GUARANTEE

3.1 GUARANTEE

Draper tools have been carefully tested and inspected before shipment and are guaranteed to be free from defective materials and workmanship.

Should the tool develop a fault, please return the complete tool to your nearest distributor or contact:

Draper Tools Limited, Chandler's Ford, Eastleigh, Hampshire, SO53 1YF. England.

Telephone Sales Desk: (023) 8049 4333 or:

Product Helpline (023) 8049 4344.

A proof of purchase must be provided.

If upon inspection it is found that the fault occurring is due to defective materials or workmanship, repairs will be carried out free of charge. This guarantee period covering parts/labour is 12 months from the date of purchase except where tools are hired out when the guarantee period is 90 days from the date of purchase. This guarantee does not apply to normal wear and tear, nor does it cover any damage caused by misuse, careless or unsafe handling, alterations, accidents, or repairs attempted or made by any personnel other than the authorised Draper warranty repair agent.

Note: If the tool is found not to be within the terms of warranty, repairs and carriage charges will be quoted and made accordingly.

This guarantee applies in lieu of any other guarantee expressed or implied and variations of its terms are not authorised.

Your Draper guarantee is not effective unless you can produce upon request a dated receipt or invoice to verify your proof of purchase within the guarantee period.

Please note that this guarantee is an additional benefit and does not affect your statutory rights.

Draper Tools Limited.

4. INTRODUCTION

4.1 SCOPE

This device generates an alternating current of high frequency. The current passes through a focusing tip and creates an alternating magnetic field which, by using the principle of electromagnetic induction vibrates electrons inside the heated material. The energy of moving electrons is dissipated as heat, which heats the metal within the work field of the instrument. The more easily magnetizable material, the more heat it creates. That is why the device heats conductive metals and their alloys easily but has no effect on glass, plastics, wood, textiles and other non-conductive materials.

4.2 SPECIFICATION

Stock No.	76171
Part No.	IHT-30
Rated voltage	230V~50/60Hz
Induction frequency	20-60Hz
Input current	max. 16A
Output power	3kW
PF@100% power	≥ 0.85
Length of induction torch	2M
Coolant content	2.5L
Dimension	240x200x440mm
Weight	13.5kg

4.3 HANDLING AND STORAGE

Care must still be taken when handling and lifting. Dropping this machine will have an effect on the accuracy and may also result in personal injury. This machine is not a toy and must be respected.

The environment will have a negative result on its operation if you are not careful. If the air is damp, components will rust. If the machine is unprotected from dust and debris; components will become clogged: And if not cleaned and maintained correctly or regularly the machine will not perform at its best.

5. HEALTH AND SAFETY INFORMATION

5.1 GENERAL RULES WHEN USING LIQUID COOLED INDUCTION HEATING TOOL

- Do not leave tool unattended while it is turned on. Always deactivate tool via the master switch when not using it for heating!
- Make sure that the unit has sufficient air supply for cooling.
- Make sure that the ventilation openings are clean and free of dust and dirt, to not restrict the flow of cooling air.
- Do not attempt to repair your tool. The device contains no user-reparable components.
- The user is responsible for the system and the use in accordance with the instructions shown in this Manual. Draper Tools is not liable for any damage due to incorrect use or operation.
- Only persons who have had correct training can operate the equipment. Do not use the equipment when under the influence of drugs, alcohol or medication.
- Keep persons standing around at a safe distance while working with the device, including while the heated material is cooling down.
- Avoid working in rain, water and humid environments. Keep the working area well ventilated and dry, clean and well lit.

5.2 ELECTRIC SHOCK

CAUTION! Never remove casing and do any activity with the induction heater unless you have first disconnected the plug from the socket. Then wait at least 2 minutes after unplugging it.

DO NOT OPERATE THE EQUIPMENT IN RAIN OR IN MOIST ENVIRONMENTS.

CAUTION! Any and all maintenance on the electrical section may only be made by persons with adequate electrical engineering qualification. Any unauthorised servicing work poses the risk of electric shock.

5.3 CAUTION! HOT SURFACE

CAUTION! Do not touch any objects located near the induction heater unless you have checked that it has cooled down.

Do not touch the induction coil when switched on.

ALWAYS wear protective gloves, goggles or other protection when handling the device as there is a risk of burns.

5.4 RISK OF FIRE

DO NOT OPERATE THE EQUIPMENT IN ENVIRONMENTS WITH AN EXPLOSION HAZARD!

Do not overheat parts.

Do not heat materials above their melting point.

Keep flammable substances outside the working area.

Do not put the device on, over or near flammable surfaces.

Do not use the machine if it is near objects that may contain flammable particles of dust, gas, vapour or liquids. After completion of work with the device, check the area to make sure everything is secure and there is no risk of sparks, flames and fire.

5. HEALTH AND SAFETY INFORMATION

5.5 SAFETY EQUIPMENT WHEN WORKING WITH THE DEVICE

Always wear protective goggles or face mask when using the tool.

Use of the device may produce dangerous waste gases from burning paints, lubricants, sealants, glues, etc. These gases may be toxic. Always use adequate protective masks or respirators.

Always use protective gloves with adequate thermal resistance when working with the device. The high temperatures produced by using the tool may cause serious burns.

5.6 ELECTROMAGNETIC EFFECTS



The electromagnetic field (EMF) may affect implanted medical devices. The device is not intended to be used by users with cardiac pacemakers or other implanted medical or surgical metallic devices (such as replacement hips/knees etc).

While working, maintain a safe distance between body parts and the induction tip, as specified in its instructions for use.

Short-term tissue exposure to high-intensity time-variable magnetic fields may lead to tissue warming by the induced current.

Long-term exposure to high-intensity time-variable magnetic fields may lead to

- undesirable effects on nerve activity
- fatigue
- headaches
- blood cell production disorders

Persons with other metallic or electronic surgical implants are not allowed to work with the tool and have to keep a safe distance of at least 1m from the device.

When working with the tool, do not wear any metal objects such as jewels, rings, watches, necklaces, identification plates, belt buckles, piercing or clothes with metal components such as metal rivets, buttons, zip fasteners, etc.

The device can heat these metal objects very fast and thus cause serious burns or even ignition of clothes!

Users of these devices should consult their medical doctor before use to discuss any issues to avoid potential troubles connected with them while handling the device.

5.7 CONNECTION TO THE POWER SUPPLY

Make sure the power supply information on the machine's rating plate are compatible with the power supply you intend to connect it to.

It is designed for connection to a power supply rated at 16Amp, 230V AC. See page 18 for Input Current Limit instructions.

Because it is constructed mostly of metal parts, it is a Class 1 machine; meaning it must have an earth connection in the power supply. This is to prevent electrocution in the event of a failure.

Apart from replacing the fuse in the plug, no other electrical work is recommended on this Induction Heating Tool.

6. TECHNICAL DESCRIPTION

6.1 IDENTIFICATION

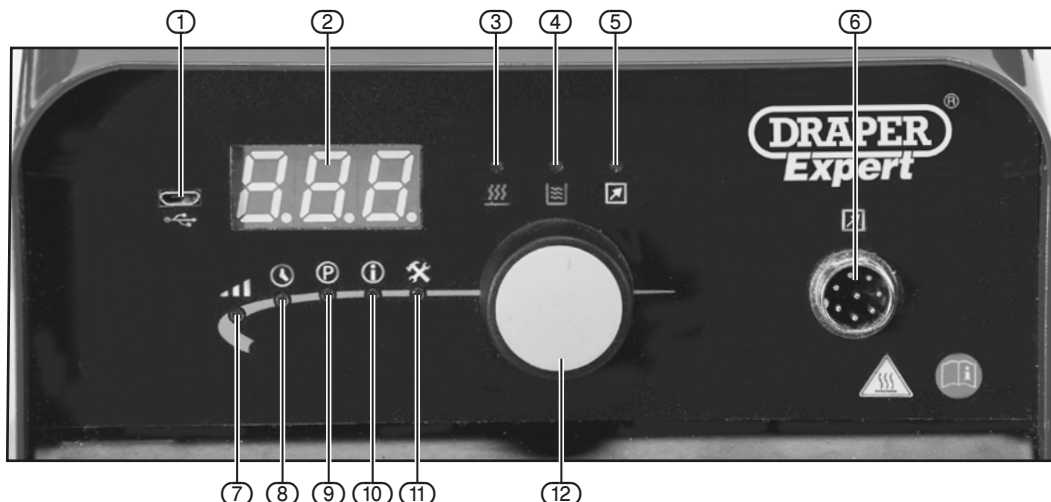

- | | | |
|-------------------------------------|---------------------------|-----------------------------|
| ① USB connector | ⑩ INFO indicator | ⑲ Induction focus head |
| ② Electronic display | ⑪ SETTING indicator | ⑳ Input control button |
| ③ Heating indicator | ⑫ Selection wheel | ㉑ Induction torch holder |
| ④ Cooling and overheating indicator | ⑬ Handle | ㉒ Cooling vents |
| ⑤ REMOTE control indicator | ⑭ LED lamp | ㉓ Handle of induction torch |
| ⑥ External control connector | ⑮ Coolant reservoir cap | ㉔ Induction torch cable |
| ⑦ Control indicator | ⑯ Coolant level indicator | |
| ⑧ TIMER indicator | ⑰ Main switch | |
| ⑨ PROGRAMME indicator | ⑱ Power cord | |

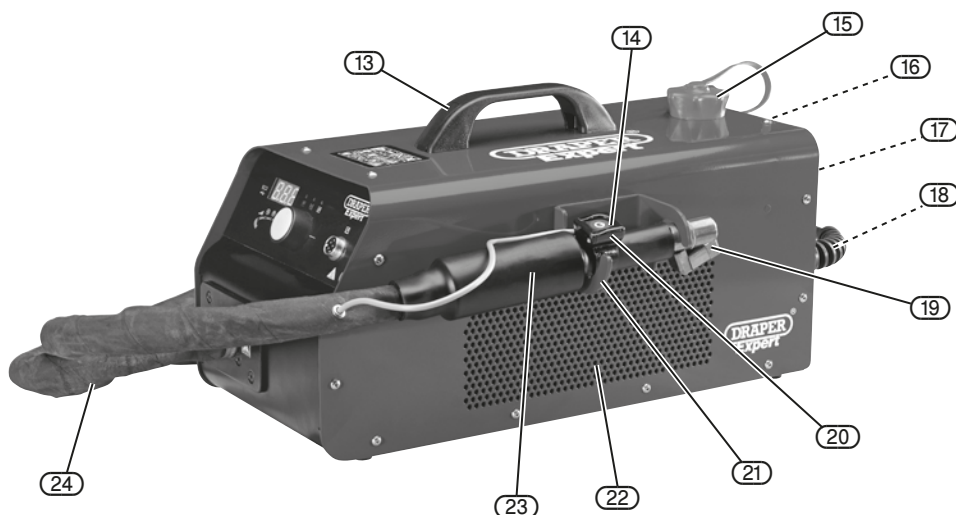

7. UNPACKING AND CHECKING

7.1 PACKAGING

Carefully remove the machine from the packaging and examine it for any sign of damage that may have happened during shipping. Lay the contents out and check them against the parts shown below. If any part is damaged or missing; please contact the Draper Helpline (the telephone number appears on the Title page) and do not attempt to use the machine.

The packaging material should be retained at least during the guarantee period: in case the machine needs to be returned for repair.

Warning! Some of the packaging materials used may be harmful to children. Do not leave any of these materials in the reach of children.

If any of the packaging is to be thrown away, make sure they are disposed of correctly; according to local regulations.

Important: Before use - you MUST remove transmit seal O-ring from liquid coolant cap (see fig.1).

Simply pull securing tab off the top of the cap. This allows the coolant to “breathe” during use.

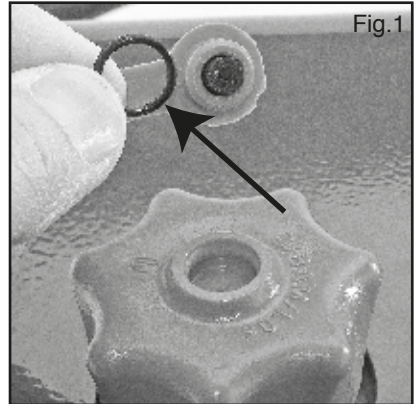

8. ASSEMBLING THE INDUCTION HEATING TOOL

8.1 UNPACKING AND FIRST START

1. Unpack the device and any accessories supplied and check that they are in good order and the device and the accessories are not damaged. If you find any defects, do not continue !
2. Leave the device to acclimatise for 15 minutes.
3. **Important:** Remove the sealing ring located under the coolant tank filling hole lid tab. Pull to remove the lid tab and take out the sealing O-ring. Then push the tab, including the foam gasket, back into the tank lid. Keep the O-ring for potential future use if sending the machine via a parcel service.
4. If the focusing head is not attached, screw it on .
5. The machine is pre filled with coolant, approximately 2.5L.
6. A plug must be fitted, a 16Amp plug is recommended to get the best performance from the machine. A 13Amp plug can be fitted but the machine **MUST** be reduced to 70% power. See page 18 for Input Current Limit instructions.
7. The cooling circuit venting is activated automatically, and the letters “FIL” flash on the electronic display during this. The coolant level decreases during the filling .
8. After completion of the venting, turn the device off and check the coolant so that the coolant level shown on the gauge at the back of the device is about 1 cm above the bottom of the tank.
9. Repeat the procedure if needed.

8.2 COOLANT REFILLING

Check and refill the liquid coolant before each device starting. Use the original Draper liquid coolant only!

DO NOT USE WATER !

The device has integrated coolant level inspection. If the coolant runs low, the device stops heating and displays the error message “E##”. In that case, refill the coolant in the tank as described in chapter 6.1 point 6 - 9.

8. ASSEMBLING THE INDUCTION HEATING TOOL

8.3 SUPPORTED TECHNOLOGIES

1) HCS3 - Heating Control System 3

This technology enables controlled heating with multiple function real time control of machine parameters, which is the heart of the device features. The induction heating system can be controlled in various modes, increasing its applicability and versatility. The ability to pre-set the parameters enables use on low amperage power supplies, where it will not trip circuit breakers etc.

2) BIPT – Boost Induction Power Technology

Enables increasing output power for better and faster material heating. This technology operates primarily in open coils, heating various types of material.

3) DIPA - Dynamic Induction Power Adjust

Automatic optimum setting of required power for achieving max. efficiency, speed and long-term heating in dependence on other heating parameters.

4) QST - Quiet Cooling Technology

An adaptive mode optimising cooling for quiet operation or maximum power output.

5) URC - Universal Remote Control

Allows universal remote device control, both analog and digital, or using a data bus, enabling easy integration into production process machinery.

6) ACMS - Automatic Check And Monitor System

Combines features that check and verify device functionality and condition after activation, and a feature that constantly supervises and monitors the heating and operational parameters for maximum device safety and reliability.

7) DFU - Device Firmware Update

Enables updates to the firmware.

Heating modes and their application

The heater has available three different heating modes:

8) Controlled Field or Burner Power Mode (CF)

In this mode, the induction heater maintains the same intensity of the magnetic field regardless of the conditions surrounding the induction tip. The heater behaves similarly to a gas burner, where the set field intensity matches the flame power. The amount of introduced heat is then easily controlled by moving the burner nearer or further from the material, similarly to flame heating.

The advantage is that it is easier to control the introduced heat as needed and, most importantly, it allows finer and sensitive heating, e.g., in car repairs (warming window edges when removing windows, bodywork plates for easier removal of stickers, rubber parts, etc.).

Another advantage is that moving the burner away does not increase the power output and resulting needless device overheating, and increases the maximum continuous heating time and saves energy.

Advantages:

- Power control by moving nearer or further .
- Fine heating.
- Lower loss in heating, particularly for open coils or when moving focus coil away from material .

9) Controlled power mode (CP)

In this mode, the device tries to deliver and maintain the set amount of introduced heat or energy to the material. The advantage is a controlled amount of heat introduced to the material, which combined with timing enables relatively accurate heating to a set temperature, e.g., for repeated pre-heating in production, etc.

8. ASSEMBLING THE INDUCTION HEATING TOOL

The disadvantage of this mode is that when moved further from the material, the device significantly increases the power output to maintain the heat delivery level to the material, thus increasing the loss and resulting in a faster device overheating. The efficiency is reduced as well.

Advantages:

- The device automatically maintains the set amount of heat introduced to the material, thus heating the material accurately.

Drawback:

- The disadvantage is the great increase in the induction output when moved away from the material or with inappropriately chosen coil, resulting in high heating load and quick temperature increase, reducing in turn the load factor and rapidly overheating the device.
- The efficiency is reduced.

10) **Controlled heating**

Using the heating timer

The device has an integrated heating timer for easy setting of desired heating time, which combined with the controlled power mode enables relatively accurate and repeatable heating with controlled heat introduction, i.e., heating to a set temperature.

8.4 **REMOTE CONTROL AND INTEGRATION INTO PRODUCTION PROCESS**

The device has a universal remote control system that enables its easy integration into automated production processes or facilitated work in small batch production. The device can be controlled using a foot pedal, switch contact, analog signal both based on voltage and current coil, and provides logical outputs informing about the system status. In the highest class, it supports full control via a digital data bus, enabling both full control and complete system monitoring.

9. INDUCTION HEATING TOOL INSTRUCTION

9.1 HEATING INDICATOR LAMP

- Indicates heating status.



Indicator lamp	Status
GREEN	Heating in progress
YELLOW	Warning: Limited heating output
RED	Heating error - overloading
FLASHING RED	Heating error - wrong coil/tip

- Cooling and overheating indicator lamp



Indicator lamp	Status
GREEN	cooling in progress
FLASHING GREEN	only water circuit active, venting
YELLOW	warning – near overheating
RED	cooling error – no coolant or hose squeezed

- REMOTE indicator lamp



Indicator lamp	Status
GREEN	remote control activated

9.2 ACTIVATING THE DEVICE

- Check the coolant level and refill if necessary.
- Connect the device to a power socket (16Amp preferred) and turn it on using the switch at the back of the device.
- The device auto diagnostic test (self-test) is initiated automatically and the cooling circuit is bled to remove air; the letters “FIL” flash on the display during this.
- If the device detects lack of coolant, it displays the error message E12: In that case, refill the coolant in the tank.
- If everything is in order, the device switches to standby.

9.3 STANDBY

This is the initial device status, which allows turning the selection wheel to set the desired heating power or temperature, depending on the mode selected:

- Controlled power mode (CP), indicator lamp glows red – the user sets the desired heating power in % of maximum heating power and the device automatically adjusts the required parameters to maintain the set power.
- Controlled magnetic field mode (CF), indicator lamp glows green – the user sets the desired field intensity in % of maximum field intensity and the device automatically maintains the set field intensity.

The indicator lamp starts flashing during the heating and the display shows the current readings of power output in kW.

9. INDUCTION HEATING TOOL INSTRUCTION

The desired heating mode can be set or switched by pressing and holding down the selection wheel (12) – the display shows the corresponding mode name CP/CF and the indicator lamp changes colour.

Press the selection wheel (12) to move to further device parameter settings, such as the heating timer, etc.

Note: If the power is controlled remotely, the letters “rc” are displayed for 3 sec when turning the encoder.

Indicator lamp	Status
RED	Heating power setting in %, mode CP
FLASHING RED	Power reading in kW during the heating
GREEN	Magnetic field intensity setting in %, mode CF
FLASHING GREEN	Power reading in kW during the heating

9.4 HEATING TIMER

The timer makes it possible to automatically stop heating after a set amount of time, enabling accurate dosing of energy (heat) to be introduced to the material, e.g., for spot or repeated heating to a set temperature.

Press the selection wheel (12) repeatedly until the TIMER indicator (8) lamp glows red. Then turn to set the desired heating time in seconds or deactivate the timer by selecting “OFF”.

If the timer is set, then the indicator lamp glows green when the heating starts, and if the heating is stopped by the timer, the indicator lamp starts flashing green and the display shows the letters “OFF” once the button is released. Releasing the button stops the heating immediately.

Note: If heating is started in the timer settings, the display will show the remaining heating time (remaining heating time countdown).

Note: Press the selection wheel (12) to enter pre-heating/program settings (see following chapter). To exit to power settings immediately, press and hold down the selection wheel (12).

Indicator lamp	Status
RED	Heating time settings
GREEN	Timer active – heating in progress
FLASHING GREEN	Timer active – timeout

9.5 INFO

Info enables the display of basic information about the heating process and the device. It facilitates selection or optimisation of induction coils for the material to be heated, removal of any error codes, etc.

If you wish to display Info, press the selection wheel (12) repeatedly until the indicator lamp glows red. Turn the selection wheel (12) to select the parameter to display and press to confirm. The display shows the latest reading (indicator lamp glows green), or shows the current reading during the heating (indicator lamp flashes green).

Press again to return to parameter selection, and you can select another one. If you wish to exit the Info display and continue to further settings, select “---” in the parameters and press to confirm. To exit to power settings immediately, press and hold down the encoder.

Indicator lamp	Status
RED	Parameter selection
FLASHING GREEN	Latest reading
FLASHING RED	Current reading during the heating

9. INDUCTION HEATING TOOL INSTRUCTION

The following parameters are available in Info:

Description	Display	Value Unit
Return / exit	---	---
Power transmitted	P	0.01 kW
Output power	Po	0.01 kVA
Power factor	PF	1%
Frequency	FrE	0.1 kHz
Input current	OC	0.1A
Output current	IC	0.1A
Input current		Vrms
Cooling temperature	tEP	0.1 °C
Limitation	OL	--- = no limitation po = max. power transmitted ic = max. input current oc = max. output current dut = max. inverter duty tE = temperature
Errors	Err	error history

Note: See annex for a list of errors.

1) P – Power transmitted

Shows the current device power output in Watt, which approximately (after deducting loss in cable and heating head) matches the power or energy introduced to the material being heated. It is thus a parameter directly related to heating speed and temperature. This transmitted power increases with growing bond (decreasing gap) between the heating coil and the material.

2) Po – Output power

Related to inverter output power and shown in VA (volt-amperes). It is the so-called apparent power. It is directly related to the power or intensity of the magnetic field that the heating coil produces. When the bond between the induction coil and material decreases, or when heating less magnetic or non-ferrous metal materials, this output power has to increase in order to maintain the same amount of energy or heat introduced to the material, increasing the loss in turn. Increasing output power can achieve higher transmitted power, enabling heating of non-ferrous metals, for example.

3) PF – Power Factor

This indicates the relative quality of the heating induction circuit and is directly related to the bond between the induction coil and the material, making this parameter very useful for selecting the optimal coil. The closer the number to 100%, the higher the efficiency of heating energy transmission to the material, and vice versa. Generally speaking, if PF=100%, all the energy goes straight into the material and the heating has maximum efficiency. With lower PF, only a part of the energy is transmitted into the material and part oscillates in the coil.

The PF is the highest with a focus adapter, applied tightly to a thick material. Moving away from the material quickly reduces the PF. For open coils, the more accurately the coil sits on the material and the smaller the gap between the coil and the material, the higher the PF and the more efficient the heating. The recommended gap is approx. 2-5 mm. With smaller gaps, heat from the material being heated is transmitted into the coil, resulting in a faster device overheating.

9. INDUCTION HEATING TOOL INSTRUCTION

4) Frequency “FrE”

The current heating frequency, which should be within 25-40 kHz with a correctly selected coil, depending on the load and the material being heated. If it deviates significantly, the device displays a warning, meaning that the user should use a more appropriate coil. If the frequency exceeds the limit values, the device turns itself off and reports an error.

5) Output current

Indicates the current delivered by the inverter to the resonance circuit in Amperes.

6) Input current

Indicates the current consumption from the power line in Amperes.

7) Input voltage

This is the current power line voltage in Volts.

It is possible to limit the input amperage if a 16Amp supply is not available.

This is also useful for use with generators, providing the generator is able to provide a stable and accurate 230V/13Amp/50Hz output, - and an output rating of at least 6kVA

8) Cooling temperature

Indicates the average temperature of the cooling liquid and device components in degrees Celsius.

9) Limitation

Indicates power or parameter limitation, if any, during the heating. For example, if the user sets the desired power to 3.5 kW using an inappropriate coil, the device will not only display a low power factor (PF), it will also indicate a duty-type limitation at the output, meaning that the inverter cannot deliver any more energy. Alternatively, if the user sets a current limit at the input to, say 10A, the device reports that the power is limited by the input current. If heating proceeds correctly and in the optimum band, the device will always display “---”, meaning that the device is not limited by anything.

10) The heating is limited:

- “---” = no limitation, heating proceeds optimally
- “po” = by maximum device power
- “ic” = by maximum input current
- “oc” = by maximum inverter output current
- “dut” = by maximum inverter output voltage
- “tE” = by max. temperature

11) Errors

Shows a history of the latest errors that have occurred in the device. Turning the selection wheel (12) clockwise shows the full error history progressively.

9. INDUCTION HEATING TOOL INSTRUCTION

9.6 SETTING

Allows for setting of the induction heater operational parameters.

Press the selection wheel (12) repeatedly until the indicator lamp glows red. Then turn the selection wheel (12) to select the parameter to display or set and press to confirm. The indicator lamp glows green.

Now you can turn the selection wheel (12) to set the desired parameter value. Press the selection wheel (12) to confirm the setting; this will return you to selection of another parameter, or select “---” to go to the next setting. To exit to power settings immediately, press and hold down the selection wheel.

1) The indicator lamp has to following statuses:

Indicator lamp	Status
RED	Parameter selection
GREEN	Value setting

The following parameters can be set:

Description	Display	Value Unit
Return / exit	---	---
Heating mode	REG	CF = constant magnetic field / current CP = constant heating power
Remote control	rc	OFF PEd = on/off control, power set on device PEA = analog, current coil (0-5V/10V)
Input Current Limit	ic.L	min 6.0A, max 16.5A = limitation on maximum input current
Max. output power	Po.L	min 2kVA, max 4.5kVA; default m is 4kVA
Cooling	CoL	Lo = silent mode (workshops, short-term capacity) Std = standard mode Hi = max. capacity / does not switch off
Water Fill	FIL	no yes = activates filling and venting
Factory setting	FAC	no YES = load factory setting
Unlock code	UnL	Servicing menu code
Firmware	Fir	Display firmware version

2) “HC“ Heating mode

Enables selection of desired heating mode – see chapter Heating modes. The following options are available:

- CF = control based on desired magnetic field intensity
- CP = control to desired heating power

3) “Po L” Maximum output power

Allows you to select the maximum inverter output power, which is convenient for small coils, limited by maximum power or current. This enables use of specialised, small or wire coils, which would otherwise overheat.

The other advantage is the possibility of limiting the max. power to the minimum required, which in combination with the CP power control mode significantly reduces device overheating and increases the heating efficiency.

9. INDUCTION HEATING TOOL INSTRUCTION

4) “ic.L” Power Line Current Limit

Enables limitation of current consumed from the power line, which permits trouble-free use of the device in power grids with poorer switch gear or low amperage availability, e.g., in repairs, construction industry, workshops, when using a generator etc.

5) “FIL” Coolant filling and venting

Used for manual activation of venting and coolant filling.

6) “CoL” Cooling settings

Used for selecting the preferred cooling mode. The following options are available:

- Lo – silent mode, where the user prefers quieter cooling and does not mind higher grip temperature. It is convenient for small workshops and production floors that require silence.
- Std, standard – optimum choice between the silent mode and maximum power, suitable for general use.
- Hi – maximum capacity mode, increasing the cooling intensity at the expense of noise. The advantages are lower grip temperature and maximum power. It finds application in more demanding uses.

7) “RC” Remote control

Remote device control settings. The following options are available:

- PEd - pedal = heating is activated by stepping on a pedal, with power set on the device.
- PEA – analog pedal = heating is activated and power adjusted by a pedal, or heating activation and deactivation is controlled by analog signal 0-5V, or 0-10V or a current coil 20mA.

8) FAC “Factory setting”

Reverts to factory settings.

9) Firmware

Displays the current device firmware version.

10) Unlock code

Allows unlocking some device settings and features by entering a code - for service agent use only.

9.7 REMOTE CONTROL

Activates remote device control via an RMT connector.

Signal	Type	Description
INPUT	analog	control signal
OUT ERROR	OC / DIG	closed on error
OUT HEATING	OC / DIG	closed during active heating

Note: The output signals are not active if DIG remote control is used.

Connector pinning

Pin	Analog IO	Digital IO
1	Common/GND	
2	Input	
3	OUTA= HEAT	MODBUS/RS485B
4	OUTB = OK	MODBUS/RS485A
5	12V	

9. INDUCTION HEATING TOOL INSTRUCTION

9.8 REPLACEABLE HEATING INDUCTOR EXTENDERS

The induction heater device comes with a basic focusing heating inductor. Other coils, extenders and heads are available - see drapertools.com.

Correct and safe functioning of the device requires the use of only original heating inductors, extenders, adaptors and other accessories in accordance with their respective instructions for use.

The lifetime of each type of heating inductor and accessory is shown in its instructions for use along with inspection and maintenance frequencies.

9.9 HEATING INDUCTOR HEAD REPLACEMENT PROCEDURE

Warning: The induction heater head is liquid cooled.

Failure to follow these instructions will lead to loss of coolant - which will prevent use of the machine if not refilled.

DO NOT refill machine with tap water, anti-freeze or any other liquid.

Use ONLY approved Draper liquid coolant.

1. Turn off the device using the switch at the back of the device.
2. Make sure the coolant tank is safely closed.
3. Grasp the grip so that it is in a vertical position with the head facing upwards, at least 20 cm above the power supply unit. Maintain this position through the entire replacement procedure.
4. Unscrew the heating inductor head by rotating it counterclockwise until it is released.
5. Make sure the threads and contact surfaces of both the grip and the extender are clean and free of signs of corrosion.
6. Mount the new complete head by freely rotating it clockwise until the outer contact surface of the extender makes permanent contact, be careful not to cross thread during replacement.
7. Turn on the device and, after an initial venting of the cooling circuit, check the coolant level and add coolant if necessary, following the procedure described in Chapter 8.2.
8. Make a visual check of the tightness of the head connection and any other connections of the new head. If there is a coolant leak, safe use of the device is no longer possible.
9. Check the conductivity of the connection by briefly activating the device without any heating inductor load.
 - If the device display shows the output power, everything is alright.
If it shows "A.Fr", the contact between the contact surfaces is incorrect. In that case, safe use of the device is no longer possible.
Check fitment of head and re-attach correctly before use.

10. MAINTENANCE & TROUBLESHOOTING

When scheduling device maintenance you have to consider the degree and circumstances of device use.

Considerate use and preventive maintenance help prevent needless defects and malfunctions. Perform checks as per standards and law in force. Only workers with adequate electrical engineering qualifications may carry out any jobs on the device.

WARNING!!

Any handling of the power supply, including maintenance, requires its disconnection from the power supply. To prevent injuries, always disconnect the power cable and wait at least 2 minutes before removing the casing. Discharge the capacitor circuits before any further work.

Periodic maintenance includes cleaning the device every half a year:

1. Disconnect the device plug from the socket and wait about 2 minutes (the capacitors inside the device will discharge). Then remove the upper device casing.
2. Clean all dirty power electric connections and tighten any loose ones.
3. Clean the internal device parts (coolers in particular) to remove dust and dirt – for example using clean compressed air, a soft brush and vacuum cleaner.
4. The upper casing has to be earthed – remember to connect the yellow-and-green earthing wire before screwing it on.
5. After maintenance, carry out safety measurements as per standards in force.

Note: Never use solvents or thinners (e.g., acetone), because they may damage insulation, plastic parts and lettering on the front panel!!

10.1 STORAGE

The device has to be stored in a clean and dry room. Protect the device from rain, direct sunshine and frost.

After heating completion, leave the device switched on for 10 more minutes - it will be cooled down by fans until it is cold, then it deactivates the fans. After that, turn it off using the master switch and disconnect it from the power supply.

If you disconnect the device immediately, leave it and all the working coils to cool down for at least 15 minutes.

10.2 LIST OF ERROR MESSAGES

Error	Description
1	Undervoltage
2	Overvoltage
3	Input overcurrent
4, 5	Output overcurrent
6	Overload
7, 8	Frequency – min/max
9, 10, 11	Resonance circuit and frequency control error
12	Out of coolant
13	Hose squeezed or clogged
14 - 18	Device overheating
19	Wrong power supply frequency
20 - 256	Device servicing errors

10. MAINTENANCE & TROUBLESHOOTING

10.3 TECHNICAL PARAMETERS

Error	Description
1	Undervoltage
2	Overvoltage
3	Input overcurrent
4, 5	Output overcurrent
6	Overload
7, 8	Frequency – min/max
9, 10, 11	Resonance circuit and frequency control error
12	Out of coolant
13	Hose squeezed or clogged
14 - 18	Device overheating
19	Wrong power supply frequency
20 - 256	Device servicing errors

11. EXPLANATION OF SYMBOLS

11.1 EXPLANATION OF SYMBOLS



Before plugging in your tool, make sure the socket voltage matches that on the product plate. If the socket voltage does not match that shown on the type plate, it can result in a serious hazard and damage to your tool.



Important: Read this Manual carefully to gain information about the device features. Inappropriate handling may cause injuries to persons and damage to the device.



Risk of death by electrocution.

Caution: Risk of electric shock!



Caution: Hot surface! Risk of burns!



Risk of fire.



Electromagnetic field risk.



Always wear! Protective goggles and protective masks.



Always use! Protective gloves.



Do not use with cardiac pacemakers or other surgically implanted electronic devices.



Do not use with surgically implanted devices such as replacement hips/knees etc.



Do not use with watches or other metal objects.

12. DISPOSAL

12.1 DISPOSAL

- At the end of the machine's working life, or when it can no longer be repaired, ensure that it is disposed of according to national regulations.
- Contact your local authority for details of collection schemes in your area.

In all circumstances:

- Do not dispose of power tools with domestic waste.
- Do not incinerate.
- Do not abandon in the environment.
- Do not dispose of WEEE* as unsorted municipal waste.



■
* Waste Electrical & Electronic Equipment.

CONTACTS

Draper Tools Limited, Hursley Road,
Chandler's Ford, Eastleigh, Hampshire. SO53 1YF. U.K.

Helpline: (023) 8049 4344

Sales Desk: (023) 8049 4333

Internet: drapertools.com

E-mail: sales@drapertools.com

General Enquiries: (023) 8026 6355

Service/Warranty Repair Agent:

For aftersales servicing or warranty repairs, please contact the
Draper Tools Helpline for details of an agent in your local area.

YOUR DRAPER STOCKIST

DBKC1019

©Published by Draper Tools Limited.

No part of this publication may be reproduced, stored in a retrieval system or transmitted in any form or by any means, electronic, mechanical photocopying, recording or otherwise without prior permission in writing from Draper Tools Ltd.