



DRAPER[®]

STORMFORCE

10.8V **CAR POLISHER**

70453



These instructions accompanying the product are the original instructions. This document is part of the product, keep it for the life of the product passing it on to any subsequent holder of the product. Read all these instructions before assembling, operating or maintaining this product.

This manual has been compiled by Draper Tools describing the purpose for which the product has been designed, and contains all the necessary information to ensure its correct and safe use. By following all the general safety instructions contained in this manual, it will ensure both product and operator safety, together with longer life of the product itself.

All photographs and drawings in this manual are supplied by Draper Tools to help illustrate the operation of the product.

Whilst every effort has been made to ensure the accuracy of information contained in this manual, the Draper Tools policy of continuous improvement determines the right to make modifications without prior warning.

1. TITLE PAGE

1.1 INTRODUCTION:

USER MANUAL FOR: 10.8V Car Polisher

Stock No: 70453

Part No: CPO108SF/K

1.2 REVISIONS:

Date first published June 2019.

As our user manuals are continually updated, users should make sure that they use the very latest version.

Downloads are available from: <http://drapertools.com/manuals>

Draper Tools Limited
Hursley Road
Chandler's Ford
Eastleigh
Hampshire
SO53 1YF
UK

Website: drapertools.com

Product Help Line: +44 (0) 23 8049 4344

General Fax: +44 (0) 23 8026 0784

1.3 UNDERSTANDING THIS MANUALS SAFETY CONTENT:

WARNING! – Information that draws attention to the risk of injury or death.

CAUTION! – Information that draws attention to the risk of damage to the product or surroundings.

1.4 COPYRIGHT © NOTICE:

Copyright © Draper Tools Limited.

Permission is granted to reproduce this publication for personal and educational use only. Commercial copying, redistribution, hiring or lending is prohibited.

No part of this publication may be stored in a retrieval system or transmitted in any other form or means without written permission from Draper Tools Limited.

In all cases this copyright notice must remain intact.

2. CONTENTS

1. TITLE PAGE	
1.1 INTRODUCTION	2
1.2 REVISION HISTORY	2
1.3 UNDERSTANDING THIS MANUAL	2
1.4 COPYRIGHT NOTICE	2
2. CONTENTS	
2.1 CONTENTS.....	3
3. WARRANTY	
3.1 WARRANTY.....	4
4. INTRODUCTION	
4.1 SCOPE.....	5
4.2 SPECIFICATION.....	5
4.3 HANDLING AND STORAGE.....	6
5. HEALTH AND SAFETY INFORMATION	
5.1 GENERAL SAFETY INSTRUCTIONS FOR POWER TOOL USE	7
5.2 SPECIFIC SAFETY INSTRUCTIONS FOR POLISHERS.....	8
5.3 SAFETY WARNINGS COMMON FOR POLISHING OPERATIONS	9
5.4 RESIDUAL RISK.....	10
5.5 SAFETY INSTRUCTIONS FOR MAINS POWERED BATTERY PACKS AND CHARGERS	11
5.6 CONNECTION TO THE POWER SUPPLY (CHARGER)	11
6. TECHNICAL DESCRIPTION	
6.1 IDENTIFICATION.....	12
7. UNPACKING AND CHECKING	
7.1 PACKAGING	13
7.2 DRAPER 10.8V MULTI-TOOL INTERCHANGEABLE BATTERY SYSTEM	13
7.3 WHAT'S IN THE BOX.....	13
8. PREPARING THE BATTERY CHARGER	
8.1 BATTERY PACK CHARGING	14
8.2 BATTERY PACK CHARGING LIGHT INDICATOR SEQUENCE	15
8.3 BATTERY PACK EFFICIENCY AND CHARGING ADVICE	15
9. PREPARING THE CAR POLISHER	
9.1 BATTERY PACK CHARGE STATUS.....	16
9.2 FITTING THE AUXILIARY HANDLE	16
9.3 FITTING THE BACKING PAD.....	17
9.4 FITTING THE ACCESSORIES	17
10. BASIC CAR POLISHER OPERATIONS	
10.1 VARIABLE SPEED TRIGGER.....	18
10.2 TRIGGER SAFETY LOCKING BUTTON	18
10.3 TWO SPEED SELECTOR SWITCH	18
11. MAINTENANCE & TROUBLESHOOTING	
11.1 MAINTENANCE	19
11.2 TROUBLESHOOTING GUIDE.....	19
12. OPTIONAL ACCESSORIES	
12.1 OPTIONAL ACCESSORIES	20
13. DISPOSAL	
13.1 DISPOSAL	21
13.2 BATTERY PACK DISPOSAL INFORMATION.....	21
14. EXPLANATION OF SYMBOLS	
14.1 EXPLANATION OF SYMBOLS	22
DECLARATION OF CONFORMITY	ENCLOSED

3. WARRANTY

3.1 WARRANTY

Draper tools have been carefully tested and inspected before shipment and are guaranteed to be free from defective materials and workmanship.

Should the tool develop a fault, please return the complete tool to your nearest distributor or contact

Draper Tools Limited, Chandler's Ford, Eastleigh, Hampshire, SO53 1YF. England.

Telephone Sales Desk: (023) 8049 4333 or Product Help Line (023) 8049 4344.

A proof of purchase **must** be provided with the tool.

If upon inspection it is found that the fault occurring is due to defective materials or workmanship, repairs will be carried out free of charge. This warranty period covering labour is 12 months from the date of purchase except where tools are hired out when the warranty period is 90 days from the date of purchase. The warranty is extended to 24 months for parts only. This warranty does not apply to any consumable parts, any type of battery or normal wear and tear, nor does it cover any damage caused by misuse, careless or unsafe handling, alterations, accidents, or repairs attempted or made by any personnel other than the authorised Draper warranty repair agent.

Note: If the tool is found not to be within the terms of warranty, repairs and carriage charges will be quoted and made accordingly.

This warranty applies in lieu of any other warranty expressed or implied and variations of its terms are not authorised.

Your Draper warranty is not effective unless you can produce upon request a dated receipt or invoice to verify your proof of purchase within the warranty period.

Please note that this warranty is an additional benefit and does not affect your statutory rights.

Draper Tools Limited.

4. INTRODUCTION

4.1 SCOPE

This hand-held cordless car polisher is intended for use on automotive bodywork, or for polishing applications on other suitable surfaces where a high-gloss finish is required. Do not attempt to use this product for sanding or grinding purposes as this could damage the motor, invalidating the warranty.

This product is intended for domestic and infrequent light trade use only. Any application other than that it was intended for, is considered misuse.

4.2 SPECIFICATION

Stock No.	70453
Part No.	CPO108SF/K
Disc diameter (backing pad)	73mm
Speed (no load)	0 – 2,500/0 – 7,500r/min
Shaft screw thread	5/16"
Sound pressure level (LpA)*:	78.6dB(A)
Sound power level (LWA)**:.....	89.6dB(A)
Uncertainty (K):	3dB(A)
Vibration Level	4.213m/s ²
Uncertainty (K):	1.5m/s ²
Weight (nett)	0.67kg

Battery pack:

Part No.	CB108LI
Type	Li-ion
Rated Voltage	10.8V
Rating	1.5Ah

Charger:

Part No.	C108LI
Rated Voltage	230V~
Rated Frequency	50Hz
Rated D.C. output voltage	10.8V
Rated D.C. output current	2.0A
Protective device rated current	2A
Construction	Class II

* *Continuous A-Weighted Sound Pressure Level at the workstation in accordance to and declared according to EN60745.*

** *The typical A-weighted noise level determined according to EN60745.*

4. INTRODUCTION

4.3 HANDLING AND STORAGE

- Care must be taken when handling this product.
 - Dropping this power tool could have an effect on its accuracy and could also result in personal injury. This product is not a toy and must be respected.
- Environmental conditions can have a detrimental effect on this product if neglected.
 - Exposure to damp air can gradually corrode components.
 - If the product is unprotected from dust and debris, components will become clogged.
 - If not cleaned and maintained correctly or regularly, the machine will not perform at its best.

5. HEALTH AND SAFETY INFORMATION

5.1 GENERAL SAFETY INSTRUCTIONS FOR POWER TOOL USE

When using any type of power tool there are steps that should be taken to make sure that you, as the user, remain safe.

Common sense and a respect for the tool will help reduce the risk of injury.

Read the instruction manual fully. Do not attempt any operation until you have read and understood this manual.

Most important you must know how to safely start and stop this machine, especially in an emergency.

Keep the work area tidy and clean. Attempting to clear clutter from around the machine during use will reduce your concentration. Mess on the floor creates a trip hazard. Any liquid spilt on the floor could result in you slipping.

Find a suitable location. If the machine is bench mounted, the location should provide good natural light or artificial lighting as a replacement. Avoid damp and dust locations as it will have a negative effect on the machine's performance. If the machine is portable do not expose the tool to rain. In all cases do not operate power tools near any flammable materials.

Keep bystanders away. Children, onlookers and passers by must be restricted from entering the work area for their own protection. The barrier must extend a suitable distance from the tool user.

Unplug and house all power tools that are not in use. A power tool should never be left unattended while connected to the power supply. They must be housed in a suitable location, away locked up and from children. This includes battery chargers.

Do not overload or misuse the tool. All tools are designed for a purpose and are limited to what they are capable of doing. Do not attempt to use a power tool (or adapt it in any way) for an application it is not designed for. Select a tool appropriate for the size of the job. Overloading a tool will result in tool failure and user injury. This covers the use of accessories.

Dress properly. Loose clothing, long hair and jewellery are all dangerous because they can become entangled in moving machinery. This can also result in parts of body being pulled into the machine. Clothing should be close fitted, with any long hair tied back and jewellery and neck ties removed. Footwear must be fully enclosed and have a non-slip sole.

Wear personal protective equipment (PPE). Dust, noise, vibration and swarf can all be dangerous if not suitably protected against. If the work involving the power tool creates dust or fumes wear a dust mask. Vibration to the hand, caused by operating some tools for longer periods must be protected against. Wear vibration reducing gloves and allow long breaks between uses. Protect against dust and swarf by wearing approved safety goggles or a face shield. These are some of the more common hazards and preventions, however, always find out what hazards are associated with the machine/work process and wear the most suitable protective equipment available.

Do not breathe contaminated air. If the work creates dust or fumes connect the machine (if possible) to an extraction system either locally or remotely. Working outdoors can also help if possible.

Move the machine as instructed. If the machine is hand held, do not carry it by the power supply cable. If the product is heavy, employ a second or third person to help move it safely or use a mechanical device. Always refer to the instructions for the correct method.

Do not overreach. Extending your body too far can result in a loss of balance and you falling. This could be from a height or onto a machine and will result in injury.

Maintain your tools correctly. A well maintained tool will do the job safely. Replace any damaged or missing parts immediately with original parts from the manufacturer. As applicable, keep blades sharp, moving parts clean, oiled or greased, handles clean, and emergency devices working.

Wait for the machine to stop. Unless the machine is fitted with a safety brake, some parts may continue to move due to momentum. Wait for all parts to stop, then unplug it from the power supply before making any adjustments, carrying out maintenance operations or just finishing using the tool.

5. HEALTH AND SAFETY INFORMATION

Remove and check setting tools. Some machinery requires the use of additional tools or keys to set, load or adjust the power tool. Before starting the power tool always check to make certain they have been removed and are safely away from the machine.

Prevent unintentional starting. Before plugging any machine in to the power supply, make sure the switch is in the OFF position. If the machine is portable, do not hold the machine near the switch and take care when putting the machine down, that nothing can operate the switch.

Carefully select an extension lead. Some machines are not suitable for use with extension leads. If the tool is designed for use outdoors, use an extension lead also suitable for that environment. When using an extended lead, select one capable of handling the current (amps) drawn by the machine in use. Fully extend the lead regardless of the distance between the power supply and the tool. Excess current (amps) and a coiled extension lead will both cause the cable to heat up and can result in fire.

Concentrate and stay alert. Distractions are likely to cause an accident. Never operate a power tool if you are under the influence of drugs (prescription or otherwise), including alcohol or if you are feeling tired. Being disorientated will result in an accident.

Have this tool repaired by a qualified person. This tool is designed to conform to the relevant international and local standards and as such should be maintained and repaired by someone qualified, using only original parts supplied by the manufacturer. This will ensure the tool remains safe to use.

5.2 SPECIFIC SAFETY INSTRUCTIONS FOR POLISHERS

Warning: Read all safety warnings and all instructions. Failure to follow the warnings and instructions may result in electric shock, fire and/or serious injury.

Save all warnings and instructions for future reference.

The term “power tool” in the warnings refers to your mains-operated (corded) power tool or battery-operated (cordless) power tool.

Work area safety

Keep work area clean and well lit. Cluttered or dark areas invite accidents.

Do not operate power tools in explosive atmospheres, such as in the presence of flammable liquids, gases or dust. Power tools create sparks which may ignite the dust or fumes.

Keep children and bystanders away while operating a power tool. Distractions can cause you to lose control.

Personal safety

Stay alert, watch what you are doing and use common sense when operating a power tool. Do not use a power tool while you are tired or under the influence of drugs, alcohol or medication. A moment of inattention while operating power tools may result in serious personal injury.

Use personal protective equipment. Always wear eye protection. Protective equipment such as dust mask, non-skid safety shoes, hard hat, or hearing protection used for appropriate conditions will reduce personal injuries.

Prevent unintentional starting. Ensure the switch is in the off-position before connecting to power source and/or battery pack, picking up or carrying the tool. Carrying power tools with your finger on the switch or energising power tools that have the switch on invites accidents.

Remove any adjusting key or wrench before turning the power tool on. A wrench or a key left attached to a rotating part of the power tool may result in personal injury.

Do not overreach. Keep proper footing and balance at all times. This enables better control of the power tool in unexpected situations.

Dress properly. Do not wear loose clothing or jewellery. Keep your hair, clothing and gloves away from moving parts. Loose clothes, jewellery or long hair can be caught in moving parts.

If devices are provided for the connection of dust extraction and collection facilities, ensure these are connected and properly used. Use of dust collection can reduce dust-related hazards.

5. HEALTH AND SAFETY INFORMATION

Power tool use and care

- **Do not force the power tool. Use the correct power tool for your application.** The correct power tool will do the job better and safer at the rate for which it was designed.
- **Do not use the power tool if the switch does not turn it on and off.** Any power tool that cannot be controlled with the switch is dangerous and must be repaired.
- **Disconnect the plug from the power source and/or the battery pack from the power tool before making any adjustments, changing accessories, or storing power tools.** Such preventive safety measures reduce the risk of starting the power tool accidentally.
- **Store idle power tools out of the reach of children and do not allow persons unfamiliar with the power tool or these instructions to operate the power tool.** Power tools are dangerous in the hands of untrained users.
- **Maintain power tools. Check for misalignment or binding of moving parts, breakage of parts and any other condition that may affect the power tool's operation. If damaged, have the power tool repaired before use.** Many accidents are caused by poorly maintained power tools.
- **Keep cutting tools sharp and clean.** Properly maintained cutting tools with sharp cutting edges are less likely to bind and are easier to control.
- **Use the power tool, accessories and tool bits etc. in accordance with these instructions, taking into account the working conditions and the work to be performed.** Use of the power tool for operations different from those intended could result in a hazardous situation.

Service

- **Have your power tool serviced by a qualified repair person using only identical replacement parts.** This will ensure that the safety of the power tool is maintained.

5.3 SAFETY WARNINGS COMMON FOR POLISHING OPERATIONS

This power tool is intended to function as a polisher. Read all safety warnings, instructions, illustrations and specifications provided with this power tool. Failure to follow all instructions listed below may result in electric shock, fire and/or serious injury

Operations such as grinding, sanding, wire brushing and cutting off are not recommended to be performed with this power tool. Operations for which the power tool was not designed may create a hazard and cause personal injury.

Do not use accessories which are not specifically designed and recommended by the tool manufacturer. Just because the accessory can be attached to your power tool, it does not assure safe operation.

The rated speed of the accessory must be at least equal to the maximum speed marked on the power tool. Accessories running faster than their rated speed can break and fly apart.

The outside diameter and the thickness of your accessory must be within the capacity rating of your power tool. Incorrectly sized accessories cannot be adequately guarded or controlled.

Do not use a damaged accessory. Before each use inspect the backing pad for cracks, tears or excessive wear. If power tool is dropped, inspect for damage or install an undamaged accessory. After inspecting or installation of accessory, position yourself and bystanders away from the plane of the rotating accessory and run the power tool at maximum no load speed for a minute, damaged accessories will usually break apart during this test time.

Wear personal protective equipment. Depending on application, use face shield safety goggles or safety glasses. As appropriate, wear dust mask, hearing protectors, gloves and workshop apron capable of stopping small abrasive or workpiece fragments. The eye protection must be capable of stopping flying debris generated by various operations.

The dust mask or respirator must be capable of filtrating particles generated by your operation. Prolonged exposure to high intensity noise may cause hearing loss. The gloves must fit well and not be loose, loose gloves could catch in rotating parts and lead to person injury.

5. HEALTH AND SAFETY INFORMATION

Keep bystanders a safe distance away from work area. Anyone entering the work area must wear personal protective equipment. Fragments of workpiece or of a broken accessory may fly away and cause injury beyond immediate area of operation.

Never lay the power tool down until the accessory has come to a complete stop. The spinning accessory may grab the surface and pull the power tool out of your control.

Do not run the power tool while carrying it at your side. Accidental contact with the spinning accessory could snag your clothing, pulling the accessory into your body.

Regularly clean the power tool's air vents. The motor's fan will draw the dust inside the housing and excessive accumulation of powdered metal may cause electrical hazards.

Do not operate the power tool near flammable materials. Sparks could ignite these materials.

Do not use accessories that require liquid coolants. Using water or other liquid coolants may result in electrocution or shock.

Kickback and Related Warnings

Kickback is a sudden reaction to a pinched or snagged rotating wheel, backing pad, brush or any other accessory. Pinching or snagging causes rapid stalling of the rotating accessory which in turn causes the uncontrolled power tool to be forced in the direction opposite of the accessory's rotation at the point of the binding.

For example, if an abrasive wheel is snagged or pinched by the workpiece, the edge of the wheel that is entering into the pinch point can dig into the surface of the material causing the wheel to climb out or kick out. The wheel may either jump toward or away from the operator, depending on direction of the wheel's movement at the point of pinching. Abrasive wheels may also break under these conditions.

Kickback is the result of power tool misuse and/or incorrect operating procedures or conditions and can be avoided by taking proper precautions as given below.

- **Maintain a firm grip on the power tool and position your body and arm to allow you to resist kickback forces. Always use auxiliary handle, if provided, for maximum control over kickback or torque reaction during start-up.** The operator can control torque reactions or kickback forces, if proper precautions are taken.
- **Never place your hand near the rotating accessory.** Accessory may kickback over your hand.
- **Do not position your body in the area where power tool will move if kickback occurs.** Kickback will propel the tool in direction opposite to the wheel's movement at the point of snagging.
- **Use special care when working corners, sharp edges etc. Avoid bouncing and snagging the accessory.** Corners, sharp edges or bouncing have a tendency to snag the rotating accessory and cause loss of control or kickback.
- **Do not attach a saw chain woodcarving blade or toothed saw blade.** Such blades create frequent kickback and loss of control.
- **Do not allow any loose portion of the polishing bonnet or its attachment strings to spin freely. Tuck away or trim any loose attachment strings.** Loose and spinning attachment strings can entangle your fingers or snag on the workpiece.

5.4 RESIDUAL RISK

Important note: Although the safety instructions and operating manuals for our tools contain extensive instructions of safe working with power tools, every power tool involves a certain residual risk which can not be completely excluded by safety mechanisms. Power tools must therefore always be operated with caution!

5. HEALTH AND SAFETY INFORMATION

5.5 SAFETY INSTRUCTIONS FOR MAINS POWERED BATTERY PACKS AND CHARGERS

Chargers

- The charger is for indoor use only.
- Prior to plugging the charger in to the supply, check that the plug and the cable are in good repair. If either are damaged, have the defective item replaced immediately by a suitably qualified person. If the casing of the battery charger is damaged, it is good policy to have the charger checked over by a suitably qualified person.
- Only use a correctly rated mains outlet to provide power, do not plug into site generators, attach to engine generators or D.C. sources. Do not use a mains socket outlet that is not switched.
- Use the correct Draper charger in conjunction with its corresponding battery pack. Do not charge any other batteries with Draper chargers. Any other application is considered misuse. Do not attempt to charge battery packs that are too hot (over 30°C) or too cold (under 5°C), if these conditions apply set the battery pack aside to “normalise” before proceeding with the charging operation.
- Set up the charger and cable in a safe place where it won't be knocked, tripped over, stepped on, etc. and where it is well ventilated. Make sure the ventilation slots in the charger case are not obstructed, plug the charger into the socket outlet. Inspect the battery pack for damage, if it is undamaged, plug it into the charger, ensuring the correct orientation. (Most chargers and batteries have ‘keys’ etc, to make sure the battery pack is not inserted incorrectly, if you are having to ‘force’ the battery pack into the charger, the chances are you have it the wrong way round, check and try again). Switch the charger on and check that the correct indicators illuminate, allow the battery pack to charge (see the Preparing the Battery Charger instructions for your charger). Once charging is complete, switch the charger off, remove the battery pack and store in a dry place, repeat the procedure if you have more than one battery pack to charge.

Caution: When the battery charger has been continuously used, the battery charger will be hot. Once the charging has been completed, give 15 minutes rest until the next charge.

- If, when the charger was switched on, the correct indications did not occur, leave for two or three minutes to allow the charger to stabilise, if the correct indications occur, allow the charging cycle to proceed as normal. If no indication appears at all switch off, remove the battery pack, unplug the charger, check that the charger contacts and the battery contacts are clean and repeat the process, if there is still no indication, switch off, remove the battery pack, unplug the charger and check the fuse. If the fuse is blown, replace and repeat the process, if the fuse blows again, or if the fuse was intact, attempt no further action. Refer the charger to a suitably qualified person for repair.

5.6 CONNECTION TO THE POWER SUPPLY (CHARGER)

- Make sure the power supply information on the charger's rating plate is compatible with the power supply you intend to connect it to.
- The charger used by this product is designed for connection to a domestic power supply rated at 230V AC.
- If an extension lead is required, use an approved and compatible lead rated for this appliance. Follow the instructions supplied with the extension lead.
- If using an extension lead, follow the instructions that came with your lead regarding maximum load while the cable is wound. If in doubt, ensure that the entire cable is unwound. Using a coiled extension lead will generate heat, which could melt the lead and cause a fire.
- †Double insulated : The charger used by this product requires no earth connection as supplementary insulation is applied to the basic insulation to protect against electric shock in the event of failure of the basic insulation.

6. TECHNICAL DESCRIPTION

6.1 IDENTIFICATION



- ① 5/16" threaded attachment point.
- ② Variable speed trigger switch.
- ③ Hand grip.
- ④ 10.8V Draper Power Interchange Li-ion battery pack.
- ⑤ Trigger safety lock button.
- ⑥ Battery charge level indicator.
- ⑦ 2 speed selector switch.
- ⑧ Spindle locking button.
- ⑨ Auxiliary handle attachment point.

7. UNPACKING AND CHECKING

7.1 PACKAGING

Carefully remove the product from the packaging and examine it for any sign of damage that may have happened during shipping. Lay the contents out and check them against the parts shown below. If any part is damaged or missing, please contact the Draper Help Line (the telephone number appears on the Title page) and do not attempt to use the product.

The packaging material should be retained at least during the warranty period, in case the machine needs to be returned for repair.

Warning!

- Some of the packaging materials used may be harmful to children. Do not leave any of these materials in the reach of children.
- If any of the packaging is to be thrown away, make sure they are disposed of correctly, according to local regulations.

7.2 DRAPER 10.8V MULTI-TOOL INTERCHANGEABLE BATTERY SYSTEM

This tool is supplied **with** a battery, and **with** a charger.

The Draper 10.8V multi-tool interchangeable range features an array of machines all running from the same battery. To find out the latest range of accessories including battery and charger please consult the Draper website for more information or to find your local Draper stockist.



7.3 WHAT'S IN THE BOX

As well as the main product, there are several parts not fitted or attached to it.

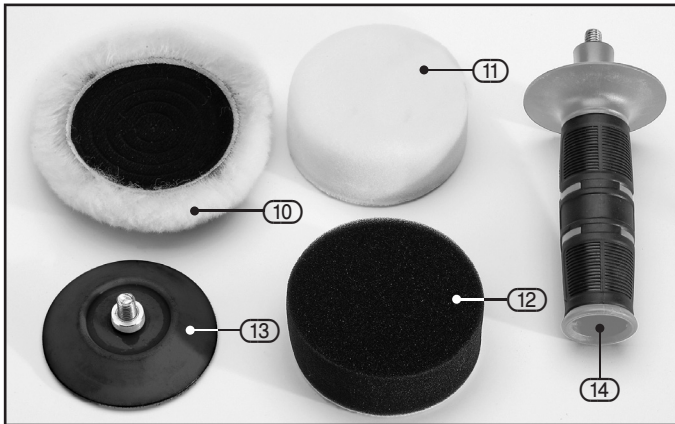

- ⑩ Wool polishing pad.
- ⑪ Medium sponge (yellow).
- ⑫ Soft sponge (black).
- ⑬ Backing pad.
- ⑭ Auxiliary handle.
- ⑮ 1.5Ah battery pack.
- ⑯ Battery charger.



8. PREPARING THE BATTERY CHARGER

8.1 BATTERY PACK CHARGING –

FIGS.1 – 3

A full range of battery packs, chargers and accessories are available from Draper Tools.

Please visit our website for details:

www.drapertools.com

Important: Only Draper designated battery packs and chargers can be used in conjunction with this product. Use of any other third party battery packs/chargers with this product is considered misuse and will invalidate the product's warranty.

Once connected to the mains supply, recharging of the battery can be left generally unsupervised, requiring minimal attention. Complex circuit construction monitors the battery condition, adjusting the recharge current to suit. When the recharge cycle is complete, to maintain the full capacity, a low output current will continue as required.

Warning! Check the condition of the charger (16) and battery prior to each charge. If there is any sign of damage then do not commence charging, seek advice from Draper Tools.

- Check the mains voltage. Make sure the voltage of the power source is the same as the voltage specified on the rating plate of the charger unit.
- Plug the battery charger mains plug into the power source. The green LED indicator (17) will blink indicating stand-by mode.
- Insert battery pack into the battery compartment of the charger. The red LED indicator (18) will light solid. This indicates that the battery pack is being fast charged automatically.
- When the battery pack is fully charged, the red LED indicator (18) will turn off and the green LED (17) will illuminate solid.
- Remove the battery pack from the charger and unplug.

Important charging notes

- Longest life and best performance can be obtained if the battery pack is charged when the surrounding air temperature is between 18°C (65°F) and 24°C (75°F).
- Do not charge battery pack in an air temperature below 4.5°C (40°F), or above 40.5°C (105°F). This is important and will prevent serious damage to the battery pack.
- The charger is designed to fast charge the battery pack between 0°C (32°F) AND 45°C (113°F). If the battery pack, when inserted, is too cold or too hot, the charger will not charge. The green LED and the red LED will blink alternatively and continuously to indicate this situation. Once the air temperature is within tolerance, the fast charging will begin.

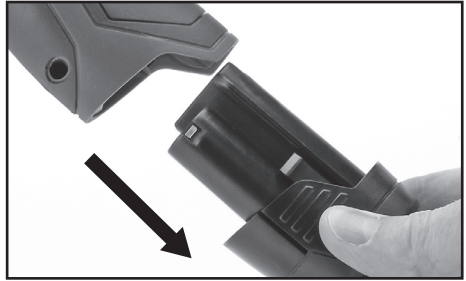

FIG.1

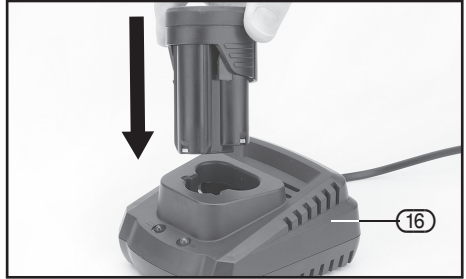

FIG.2

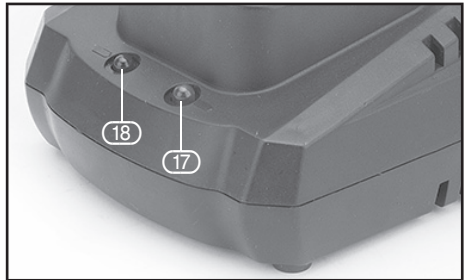

FIG.3

8. PREPARING THE BATTERY CHARGER

8.2 BATTERY PACK CHARGING LIGHT INDICATOR SEQUENCE

LED Indicator		Situation
Green	Red	
Blinking light	No light	Stand by
No light	Solid light	Charging
Solid light	No light	Charging is complete
Blinking light	Blinking light	Battery pack is too hot or too cold (charging will begin automatically when battery reaches correct charging temperature)
No light	Blinking light	Damaged or faulty battery pack

8.3 BATTERY PACK EFFICIENCY AND CHARGING ADVICE

- Recharge the battery packs before they become completely exhausted.
- When you feel that the power of the tool becomes weaker, stop using the tool and recharge the battery pack. If you continue to use the tool and exhaust the electric current, the battery pack may become damaged.
- Avoid recharging at high temperatures. A rechargeable battery pack will be hot immediately after use. If such a battery pack is recharged immediately after use, its internal chemical substance will deteriorate and the battery life will be shortened. Leave the battery pack and recharge it after it has cooled for a while.
- The battery pack should only be used and/or charged when battery pack temperature is between 5°C and 30°C.
- The battery pack needs to be warmed-up or cooled down in order to prevent damage to the batteries internal components.

Note: Failure to warm up or cool down a battery pack could result in serious damage to the battery, charger and user.

Warning: If any of the following occurs, unplug the charger from the power supply socket outlet and replace the battery pack

- None of the indicators illuminate.

Disconnect battery charger from the power supply.

Caution: Do not pull the plug out of the power supply by pulling on the cord. Make sure to grasp the plug when removing from power supply to avoid damaging the cord.

Remove the battery from the battery charger.

Supporting the battery charger with hand, pull out the battery from the battery charger

Caution: When the battery charger has been continuously used, the battery charger will be hot.

Once the charging has been completed, give 15 minutes rest until the next charge.

If the battery is charged when it is warm due to battery use or exposure to sunlight, the battery will not be recharged. In such a case, let the battery cool before charge.

If the red indicator flickers rapidly at 0.2 - second intervals, check for and take out any foreign objects in the charger's battery slot. If there are no foreign objects, it is probable that the battery or charger is malfunctioning. Allow battery/charger to normalise and try again. If a fault remains after trying this then contact Draper Tools.

How to make the batteries perform longer.

Recharge the batteries before they become completely exhausted.

When you feel that the power of the tool becomes weaker, stop using the tool and recharge the battery. If you continue to use the tool and exhaust the electric current, the battery may become damaged.

Avoid recharging at high temperatures.

A rechargeable battery will be hot immediately after use. If such a battery is recharged immediately after use, its internal chemical substance will deteriorate, and the battery life will be shortened. Leave the battery and recharge it after it has cooled for a while.

9. PREPARING THE CAR POLISHER

9.1 BATTERY PACK CHARGE STATUS

– FIG.4

The amount of charge remaining in the battery pack is indicated by the display (6) located just above the handle section.

- The display is made up of three lights that illuminate every time the ON/OFF trigger is depressed.
- The level of charge remaining determines how many of the lights will illuminate – 1, being minimal low power, to all 3 indicating full charge.



FIG.4

9.2 FITTING THE AUXILIARY HANDLE

– FIG.5

An additional auxiliary side handle (14) is provided with the polisher. The auxiliary handle provides maximum control and gives added safety protection against kickback or torque reaction during start-up.

- To fit simply screw the handle clockwise into one of the auxiliary handle attachment points (9) located on either the left or right side of the tool body.



FIG.5

9. PREPARING THE CAR POLISHER

9.3 FITTING THE BACKING PAD

– FIGS.6 – 7

The polisher uses a backing pad (13) that is attached to the tool via a threaded shaft. Once the backing pad is in place, the accessories can be fitted onto the pad using a simple 'hook and loop' system of attachment.

To fit the backing pad:

- Press the spindle locking button (8) to lock the spindle and prevent it from rotating.
- Keeping the button pressed in, insert the threaded shaft of the backing pad into the 5/16" threaded attachment point (1) and screw clockwise until tightened.

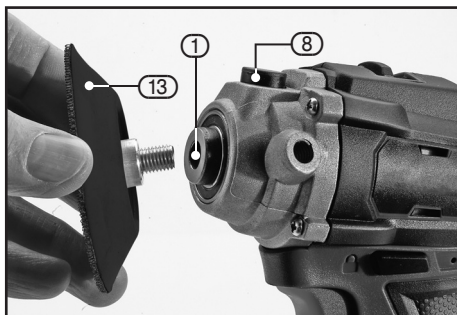

FIG.6

9.4 FITTING THE ACCESSORIES –

FIGS.8 – 9

The accessories are fitted to the backing pad (13) by means of a simple 'hook and loop' system of attachment.

To fit an accessory:

- Align the white fastening side of the accessory with the backing pad (13), making sure it's located centrally over the pad.
- Push together. The hook and loop feature will grip the accessory firmly in place.



FIG.7

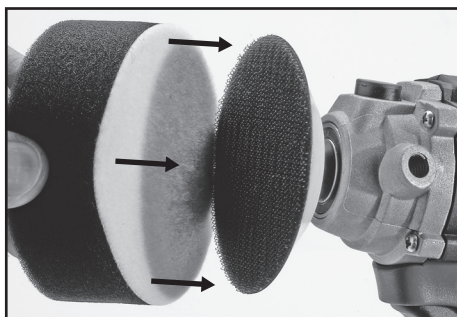

FIG.8



FIG.9

10. BASIC CAR POLISHER OPERATIONS

10.1 VARIABLE SPEED TRIGGER – FIG.10

When the trigger (2) is depressed, the drive will rotate. This trigger switch is electronic which enables the user to vary the speed continuously.

- The speed varies according to how far the trigger switch is depressed.
- The further it is depressed, the faster the drive spindle will rotate.
- The lighter it is depressed, the slower it will rotate.



FIG.10

10.2 TRIGGER SAFETY LOCKING BUTTON – FIG.11

The polisher features a safety locking button (5) that can be activated to prevent accidental activation of the trigger switch.

The locking button works by way of a sliding mechanism that transverses the handle section of the tool.

- With the polishing end of the tool facing left, press the button in to lock the trigger.
- To unlock, press the button back from the other side of the handle section.

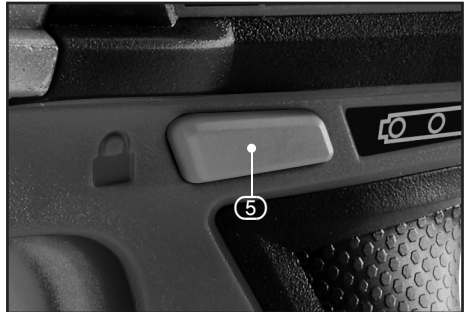

FIG.11

10.3 TWO SPEED SELECTOR SWITCH – FIG.12

The speed of the polisher can be varied when using the variable speed trigger. For added versatility, the polisher also incorporates a 2 speed selector switch (7), giving a potential range of operating speeds from 0 – 7,500* revolutions per minute.

**No load speed. Speeds will be less when tool is operating under load.*

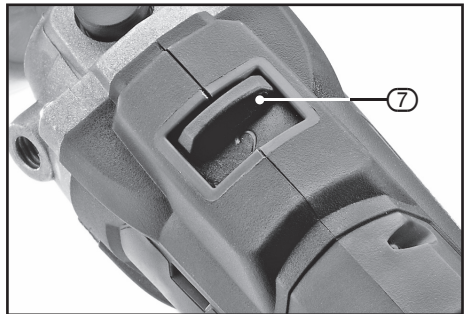

FIG.12

11. MAINTENANCE & TROUBLESHOOTING

11.1 MAINTENANCE

Regular inspection and cleaning reduces the necessity for maintenance operations and will keep your tool in good working condition.

The motor must be correctly ventilated during tool operation. Avoid blocking the air inlets and vacuum the ventilation slots regularly.

- Remove the pads when not in use to allow them to dry out.
- Clean the wool polishing pad by hand with soap and water.

11.2 TROUBLESHOOTING GUIDE

Note: Remove the battery pack before carrying out adjustment, servicing or maintenance.

Problems	Possible cause	Required action
Motor does not start.	<ul style="list-style-type: none">– Battery pack no charge.– Battery faulty or damaged.	<ul style="list-style-type: none">– Re-charge battery.– Replace battery.
Motor runs, but slowly/ losing power.	<ul style="list-style-type: none">– Battery pack no charge.– Battery pack faulty or damaged.	<ul style="list-style-type: none">– Re-charge battery.– Replace battery.
Battery pack doesn't charge / non-illumination / non illumination of charger.	<ul style="list-style-type: none">– Fuse blown in charger plug.– Charger faulty.	<ul style="list-style-type: none">– Replace fuse.– Replace charger.

12. OPTIONAL ACCESSORIES

12.1 OPTIONAL ACCESSORIES

A full range of accessories are available from Draper Tools.

Please visit our website for details: www.drapertools.com

13. DISPOSAL

13.1 DISPOSAL

- At the end of the machine's working life, or when it can no longer be repaired, ensure that it is disposed of according to national regulations.
- Contact your local authority for details of collection schemes in your area.

In all circumstances:

- Do not dispose of power tools with domestic waste.
- Do not incinerate.
- Do not dispose of WEEE* as unsorted municipal waste.



Li-ion

* *Waste Electrical & Electronic Equipment.*

13.2 BATTERY PACK DISPOSAL INFORMATION

Warning!

- Do not put battery pack in fire or mutilate – cells may burst or release toxic materials.
- Do not short circuit cells, may cause burns.
- The battery pack must be removed from the appliance before it is scrapped.
- The battery pack is to be disposed of safely.
- Do not mutilate batteries, corrosive electrolyte will be released.
- Do not dispose of batteries or cells in a charged condition.

Expired batteries must be recycled/disposed of in accordance with the appropriate regulation or legislation. They should be returned to your local warranty agent/stockist.

14. EXPLANATION OF SYMBOLS

14.1 EXPLANATION OF SYMBOLS



Read the instruction manual.



Wear safety glasses and dust mask.



Wear ear defenders.



Wear protective gloves.



Do not abandon into the environment.



Keep out of the reach of children.



Long and loose hair must be contained or securely tied back.



Warning!



Single value noise marking.
(Maximum declared A-Weighted sound power level in decibels).



Class II construction
(Double insulated).



WEEE –
Waste Electrical &
Electronic Equipment.
Do not dispose of Waste Electrical & Electronic Equipment in with domestic rubbish.



Lithium-ion product.

Li-ion



Do not incinerate or
throw onto fire.



For indoor use only.
Do not expose to rain.



Short-circuit-proof safety
isolating transformer



Fuse protective device.



Polarity indication.



Rated voltage.

CONTACTS

Draper Tools Limited, Hursley Road,
Chandler's Ford, Eastleigh, Hampshire. SO53 1YF. U.K.

Help Line: (023) 8049 4344

Sales Desk: (023) 8049 4333

Internet: drapertools.com

E-mail: sales@drapertools.com

General Enquiries: (023) 8026 6355

Service/Warranty Repair Agent:

For aftersales servicing or warranty repairs, please contact the Draper Tools Help Line for details of an agent in your local area.

YOUR DRAPER STOCKIST

RWTL0619

©Published by Draper Tools Limited.

No part of this publication may be reproduced, stored in a retrieval system or transmitted in any form or by any means, electronic, mechanical photocopying, recording or otherwise without prior permission in writing from Draper Tools Ltd.