

**DRAPER**®

500W

# GRASS TRIMMER

45927

**IMPORTANT:** PLEASE READ THESE INSTRUCTIONS CAREFULLY TO ENSURE THE SAFE AND EFFECTIVE USE OF THIS PRODUCT.



## INSTRUCTIONS

These instructions accompanying the product are the original instructions. This document is part of the product, keep it for the life of the product passing it on to any subsequent holder of the product. Read all these instructions before assembling, operating or maintaining this product.

This manual has been compiled by Draper Tools describing the purpose for which the product has been designed, and contains all the necessary information to ensure its correct and safe use. By following all the general safety instructions contained in this manual, it will ensure both product and operator safety, together with longer life of the product itself.

All photographs and drawings in this manual are supplied by Draper Tools to help illustrate the operation of the product.

Whilst every effort has been made to ensure the accuracy of information contained in this manual, the Draper Tools policy of continuous improvement determines the right to make modifications without prior warning.

# 1. TITLE PAGE

---

## 1.1 INTRODUCTION:

USER MANUAL FOR:

### 500W GRASS TRIMMER

Stock no. 45927.

Part no. GT530B.

## 1.2 REVISIONS:

\_\_\_\_\_  
Date first published January 2017  
\_\_\_\_\_  
\_\_\_\_\_  
\_\_\_\_\_

As our user manuals are continually updated, users should make sure that they use the very latest version.

Downloads are available from: <http://www.drapertools.com/manuals>

DRAPER TOOLS LIMITED

HURSLEY ROAD

CHANDLER'S FORD

EASTLEIGH

HAMPSHIRE

SO53 1YF

UK

WEBSITE: [drapertools.com](http://drapertools.com)

PRODUCT HELP LINE: +44 (0) 23 8049 4344

GENERAL FAX: +44 (0) 23 8026 0784

## 1.3 UNDERSTANDING THIS MANUALS SAFETY CONTENT:

**WARNING!** Information that draws attention to the risk of injury or death.

**CAUTION!** Information that draws attention to the risk of damage to the product or surroundings.

## 1.4 COPYRIGHT © NOTICE:

Copyright © Draper Tools Limited.

Permission is granted to reproduce this publication for personal & educational use only.

Commercial copying, redistribution, hiring or lending is prohibited.

No part of this publication may be stored in a retrieval system or transmitted in any other form or means without written permission from Draper Tools Limited.

In all cases this copyright notice must remain intact.

---

# 2. CONTENTS

---

## 2.1 CONTENTS

<b>Page content</b>	<b>Page</b>
1 TITLE PAGE	
1.1 INTRODUCTION .....	2
1.2 REVISION HISTORY .....	2
1.3 UNDERSTANDING THIS MANUAL .....	2
1.4 COPYRIGHT NOTICE .....	2
2 CONTENTS	
2.1 CONTENTS .....	3
3 GUARANTEE	
3.1 GUARANTEE .....	4
4 INTRODUCTION	
4.1 SCOPE .....	5
4.2 SPECIFICATION .....	5
4.3 HANDLING & STORAGE .....	5
5 HEALTH & SAFETY INFORMATION	
5.1 GENERAL SAFETY INSTRUCTIONS .....	6
5.2 ADDITIONAL SAFETY INSTRUCTIONS .....	7
5.3 CAUTION: RISK OF ELECTRIC SHOCK. DO NOT OPEN. ....	8
6 TECHNICAL DESCRIPTION	
6.1 IDENTIFICATION .....	9
7 UNPACKING & CHECKING	
7.1 PACKAGING .....	10
7.2 WHAT'S IN THE BOX? .....	10
8 ASSEMBLY	
8.1 ATTACH AUXILIARY HANDLE ASSEMBLY .....	11
8.2 ATTACH GUARD ASSEMBLY .....	11
9 PREPARATIONS	
9.1 AUXILIARY HANDLE .....	12
9.2 SHAFT LENGTH .....	12
9.3 HEAD ROTATION .....	12
9.4 HEAD ANGLE .....	12
9 OPERATING INSTRUCTIONS	
9.1 ON/OFF TRIGGER SWITCH .....	13
9.2 FLOWER GUARD .....	14
9.3 GUIDE WHEEL FOR EDGING .....	14
9.4 CUTTING HEAD .....	15
9.5 GENERAL CUTTING ACTION .....	15
10 MAINTENANCE AND PARTS REPLACEMENT	
10.1 MAINTENANCE AND PARTS REPLACEMENT .....	16
11 EXPLANATION OF SYMBOLS	
11.1 EXPLANATION OF SYMBOLS .....	17
12 DISPOSAL	
12.1 DISPOSAL .....	18
DECLARATION OF CONFORMITY .....	ENCLOSED

# 3. GUARANTEE

---

## 3.1 GUARANTEE

Draper tools have been carefully tested and inspected before shipment and are guaranteed to be free from defective materials and workmanship.

Should the tool develop a fault, please return the complete tool to your nearest distributor or contact Draper Tools Limited, Chandler's Ford, Eastleigh, Hampshire, SO53 1YF. England.

Telephone Sales Desk: (023) 8049 4333 or Product Help Line (023) 8049 4344.

A proof of purchase must be provided with the tool.

If upon inspection it is found that the fault occurring is due to defective materials or workmanship, repairs will be carried out free of charge. This guarantee period covering parts/labour is 12 months from the date of purchase except where tools are hired out when the guarantee period is 90 days from the date of purchase. The guarantee is extended to 24 months for parts only. This guarantee does not apply to normal wear and tear, nor does it cover any damage caused by misuse, careless or unsafe handling, alterations, accidents, or repairs attempted or made by any personnel other than the authorised Draper warranty repair agent.

Note: If the tool is found not to be within the terms of warranty, repairs and carriage charges will be quoted and made accordingly.

This guarantee applies in lieu of any other guarantee expressed or implied and variations of its terms are not authorised.

Your Draper guarantee is not effective unless you can produce upon request a dated receipt or invoice to verify your proof of purchase within the guarantee period.

Please note that this guarantee is an additional benefit and does not affect your statutory rights.

Draper Tools Limited.

## 4. INTRODUCTION

---

### 4.1 SCOPE

This machine is used for cutting grass in hard-to-reach areas - around garden furniture for example, or tidying around borders where a lawn mower can not go. Any other application is considered mis-use.

### 4.2 SPECIFICATION

Stock no. ....	45927
Part no. ....	GT530B
Rated voltage .....	230V~50Hz
Rated input .....	500W
Revolutions per minute (no load).....	9600min <sup>-1</sup>
Cutting diameter Ø .....	300mm
Nylon line:	
spool .....	Double line
length .....	6M
diameter Ø .....	1.4mm
Sound pressure level.....	74.29dB(A)
Sound power level .....	94.29dB(A)
Single value noise level†.....	96dB(A)
Vibration level .....	4.675m/s <sup>2</sup> (main handle) 1.94m/s <sup>2</sup> (auxiliary handle)
Weight (machine only).....	2.7kg

### 4.3 HANDLING & STORAGE

Care must still be taken when handling and lifting. Dropping this machine will have an effect on the accuracy and may also result in personal injury. This machine is not a toy and must be respected.

The environment will have a negative result on its operation if you are not careful. If the air is damp, components will rust. If the machine is unprotected from dust and debris; components will become clogged: And if not cleaned and maintained correctly or regularly the machine will not perform at its best.

# 5. HEALTH & SAFETY INFORMATION

## 5.1 GENERAL SAFETY INSTRUCTIONS

### General Power Tools Safety Warnings

**WARNING:** Read all instructions. Failure to follow all instructions listed below may result in electric shock, fire and/or serious injury.

Save all warnings and instructions for future reference.

The term "power tool" in the warnings refers to your mains operated (corded) power tool or battery operated (cordless) power tool.

- 1) Work area safety
  - a) Keep work area clean and well lit. Cluttered or dark areas invite accidents.
  - b) Do not operate power tools in explosive atmospheres, such as in the presence of flammable liquids, gases or dust. Power tools create sparks which may ignite the dust or fumes.
  - c) Keep children and bystanders away while operating a power tool. Distractions can cause you to lose control.
- 2) Electrical Safety
  - a) Power tool plugs must match the outlet. Never modify the plug in any way. Do not use any adapter plugs with earthed (grounded) power tools. Unmodified plugs and matching outlets will reduce risk of electrical shock.
  - b) Avoid body contact with earthed or grounded surfaces such as pipes, radiators, ranges and refrigerators. There is an increased risk of electric shock if your body is earthed or grounded.
  - c) Do not expose power tools to rain or wet conditions. Water entering a power tool will increase the risk of electric shock.
  - d) Do not abuse the cord. Never use the cord for carrying, pulling or unplugging the power tool. Keep cord away from heat, oil, sharp edges or moving parts. Damaged or entangled cords increase the risk of electric shock.
  - e) When operating a power tool outdoors, use an extension cord suitable for outdoor use. Use of a cord suitable for outdoor use reduces the risk of electric shock.
  - f) If operating a power tool in a damp location is unavoidable, use a residual current device (RCD) protected supply. Use of an RCD reduces the risk of electric shock.
- 3) Personal Safety
  - a) Stay alert, watch what you are doing and use common sense when operating a power tool. Do not use a power tool while you are tired or under the influence of drugs, alcohol or medication. A moment of inattention while operating power tools may result in serious personal injury.
  - b) Use personal protective equipment. Always wear eye protection. Protective equipment such as dust mask, nonskid safety shoes, hard hat, or hearing protection used for appropriate conditions will reduce personal injuries.
  - c) Prevent unintentional starting. Ensure the switch is in the off position before connecting to power source and/or battery pack, picking up or carrying the tool. Carrying power tools with your finger on the switch or energising power tools that have the switch on invites accidents.
  - d) Remove any adjusting key or wrench before turning the power tool on. A wrench or a key left attached to a rotating part of the power tool may result in personal injury.
  - e) Do not overreach. Keep proper footing and balance at all times. This enables better control of the power tool in unexpected situations.
  - f) Dress properly. Do not wear loose clothing or jewellery. Keep your hair, clothing and gloves away from moving parts. Loose clothes, jewellery or long hair can be caught in moving parts.
  - g) If devices are provided for the connection of dust extraction and collection facilities, ensure these are connected and properly used. Use of dust collection can reduce dust related hazards.
- 4) Power Tool Use And Care
  - a) Do not force the power tool. Use the correct power tool for your application. The correct power tool will do the job better and safer at the rate for which it was designed.
  - b) Do not use the power tool if the switch does not turn it on and off. Any power tool that cannot be controlled with the switch is dangerous and must be repaired.
  - c) Disconnect the plug from the power source and/or the battery pack from the power tool before making any adjustments, changing accessories, or storing power tools. Such preventive safety measures reduce the risk of starting the power tool accidentally.
  - d) Store idle power tools out of the reach of children and do not allow persons unfamiliar with the power tool or these instructions to operate the power tool. Power tools are dangerous in the hands of untrained users.
  - e) Maintain power tools. Check for misalignment or binding of moving parts, breakage of parts and any other condition that may affect the power tools operation. If damaged, have the power tool repaired before use. Many accidents are caused by poorly maintained power tools.
  - f) Keep cutting tools sharp and clean. Properly maintained cutting tools with sharp cutting edges are less likely to bind and are easier to control.
  - g) Use the power tool, accessories and tool bits etc., in accordance with these instructions, taking into account the working conditions and the work to be performed. Use of the power tool for operations different from intended could result in a hazardous situation.
- 5) Battery tool use and care
  - a. Recharge only with the charger specified by the manufacturer. A charger that is suitable for one type of battery pack may create a risk of fire when used with another battery pack.
  - b. Use power tools only with specifically designated battery packs. Use of any other battery packs may create a risk of injury and fire.
  - c. When battery pack is not in use, keep it away from other metal objects, like paper clips, coins, keys, nails, screws or other small metal objects, that can make a connection from one terminal to another. Shorting the battery terminals together may cause burns or a fire.
  - d. Under abusive conditions, liquid may be ejected from the battery; avoid contact. If contact accidentally occurs, flush with water. If liquid contacts eyes, additionally seek medical help. Liquid ejected from the battery may cause irritation or burns.
- 6) Service
  - a. Have your power tool serviced by a qualified repair person using only identical replacement parts. This will ensure that the safety of the power tool is maintained.

# 5. HEALTH & SAFETY INFORMATION

---

## 5.2 ADDITIONAL SAFETY INSTRUCTIONS

**WARNING:** When using the machine the safety rules must be followed. For your own safety and that of bystanders please read these instructions before operating the machine. Please keep the instructions safe for later use.

### 1) Personal Safety

- a) Wear protective glasses or goggles.
- b) Never allow children or people unfamiliar with the instructions to use the machine.
- c) Stop using the machine while people, especially children, or pets are nearby.
- d) Only use the machine in daylight or good artificial light.
- e) Before using the machine and after any impact, check for signs of wear or damage and repair as necessary.
- f) Never operate the machine with damaged guards or without the guards in place.
- g) Keep hands and feet away from the cutting means at all times and especially on the motor.
- h) Take care against injury from any device fitted for trimming the filament line length. After extending new cutter line always return the machine to its normal operating position before switching on.
- i) Never fit metal cutting elements.
- j) Never use replacement parts or accessories not provided or recommended by the manufacturer.
- k) Disconnect the machine from the mains before checking, cleaning or working on the machine and when it is not in use.
- l) Always ensure that ventilation openings are kept clear of debris.

### 2) Service

- a) After use, disconnect the machine from the mains and check for damage.
- b) When not in use store the machine out of reach of children.
- c) Mains powered trimmers should only be repaired by an authorised repairer.
- d) Use only manufacturer's recommended replacement parts and accessories.

### 3) Additional grass trimmer safety instructions

- a) Read the instructions carefully.
- b) Be familiar with the controls and proper use of equipment.
- c) Before use check the supply and extension cord for signs of damage or ageing.
- d) If the cord becomes damaged during use, disconnect the cord from the supply immediately. **DO NOT TOUCH THE CORD BEFORE DISCONNECTING THE SUPPLY.**
- e) Do not use the trimmer, if the cords are damaged or worn.
- f) **WARNING:** Cutting elements continue to rotate after the motor is switched off.
- g) Keep extension cords away from cutting elements.
- h) For safe operation of this appliance it should be supplied via a residual current device (RCD) with a tripping current of no more than 30mA.

## 5. HEALTH & SAFETY INFORMATION

---

### 5.3 CAUTION: RISK OF ELECTRIC SHOCK. DO NOT OPEN.

**Caution:** Risk of electric shock. Do not open.

This appliance is supplied with a moulded 3 pin mains plug for your safety. The value of the fuse fitted is marked on the pin face of the plug. Should the fuse need replacing, ensure the substitute is of the correct rating, approved to BS1362 and ASTA or BS Kite marked.

ASTA 

BSI 

The fuse cover is removable with a small plain slot screwdriver. Ensure the fuse cover is replaced before attempting to connect the plug to an electrical outlet. If the cover is missing, a replacement must be obtained or the plug replaced with a suitable type.

If a replacement plug is to be fitted this must be carried out by a qualified electrician.

The damaged or incomplete plug, when cut from the cable should be disabled to prevent connection to a live electrical outlet.

This appliance is Class II<sup>†</sup> and is designed for connection to a power supply matching that detailed on the rating label and compatible with the plug fitted.

If an extension lead is required, use an approved and compatible lead rated for this appliance. Follow all the instruction supplied with the extension lead.



<sup>†</sup>Double insulated : This product requires no earth connection as supplementary insulation is applied to the basic insulation to protect against electric shock in the event of failure of the basic insulation.

**Important:** On products exceeding 2000W it is recommended that the power cable and/or extension cable are fully unwound before a connection is made to the power supply. However, ensure the residual cable does not pose a trip hazard



**WARNING:**

Some of the contents of this grass trimmer have sharp edges.

The guard  contains the line length trimming blade  which is sharp!





## 6. TECHNICAL DESCRIPTION

### 6.1 IDENTIFICATION



① Double line spool

② Guide wheel

③ Flower guard

④ Line length trimming blade

⑤ Telescopic tube adjustment

⑥ Handle rotation locking catch

⑦ Auxiliary handle lock knob

⑧ Auxiliary handle

⑨ Trigger safety lock

⑩ On/off trigger switch

⑪ Cable restraint

⑫ Cable and plug

⑬ Foot latch for head angle adjustment

⑭ Guard

⑮ Filament line

## 7. UNPACKING & CHECKING

### 7.1 PACKAGING

Carefully remove the product from the packaging and examine it for any sign of damage that may have happened during shipping. Lay the contents out and check them against the parts shown below. If any part is damaged or missing; please contact the Draper Help Line (the telephone number appears on the Title page) and do not attempt to use the tool.

The packaging material should be retained at least during the guarantee period: in case the machine needs to be returned for repair.

Warning! Some of the packaging materials used may be harmful to children. Do not leave any of these materials in the reach of children.

If any of the packaging is to be thrown away, make sure they are disposed of correctly; according to local regulations.

### 7.2 WHAT'S IN THE BOX?

As well as the product; there are several parts not fitted or attached to it.

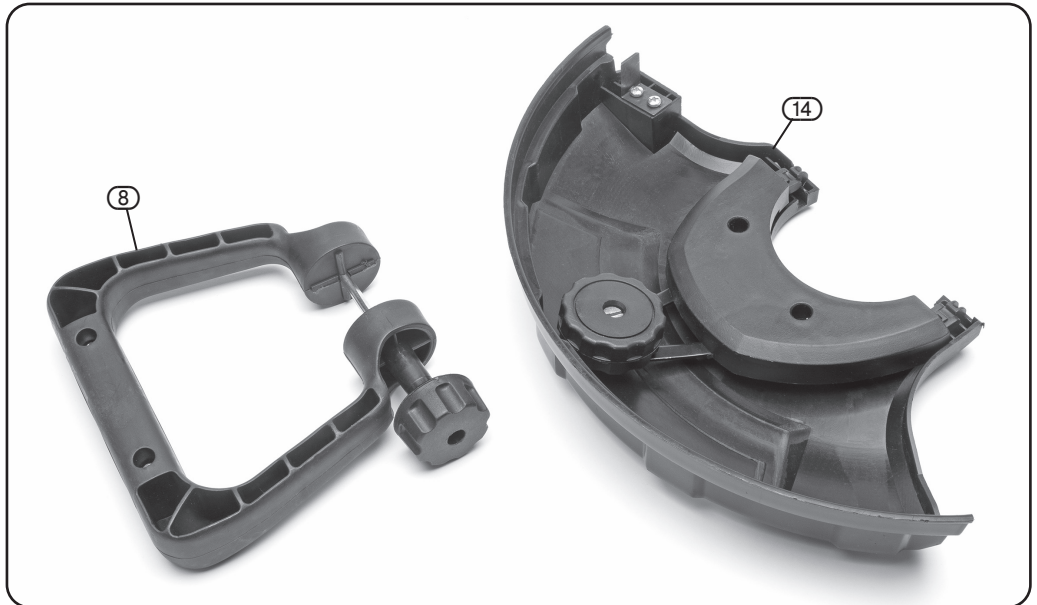

⑧ Auxiliary handle

⑭ Guard assembly

## 8. ASSEMBLY

### 8.1 ATTACH AUXILIARY HANDLE ASSEMBLY- FIGS. 1 - 2

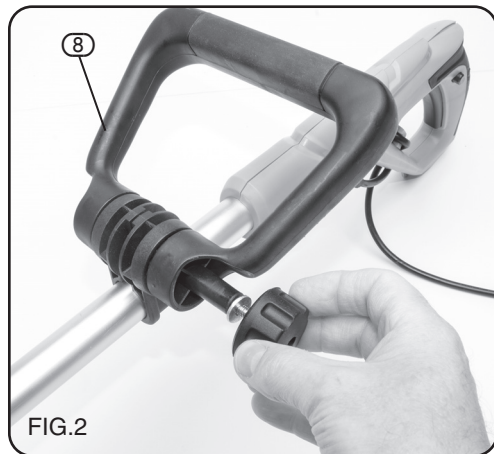
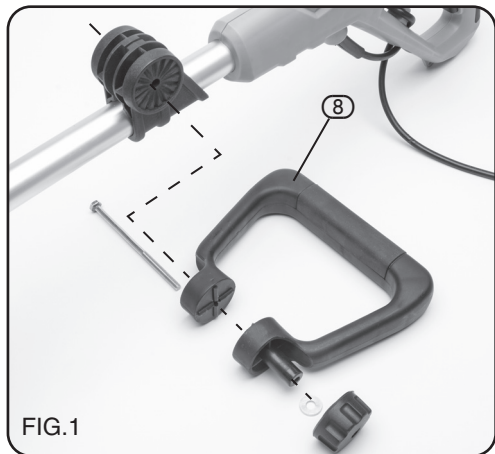

### 8.2 ATTACH GUARD ASSEMBLY - FIGS. 3 - 4

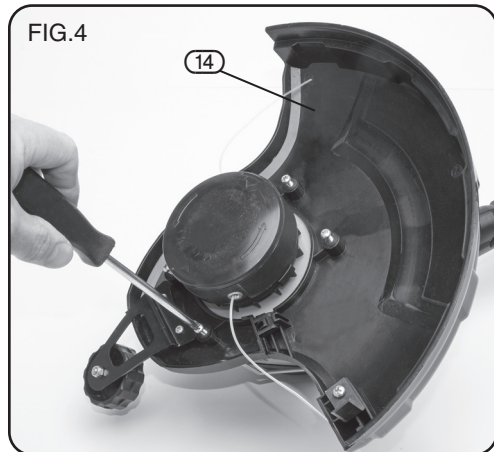
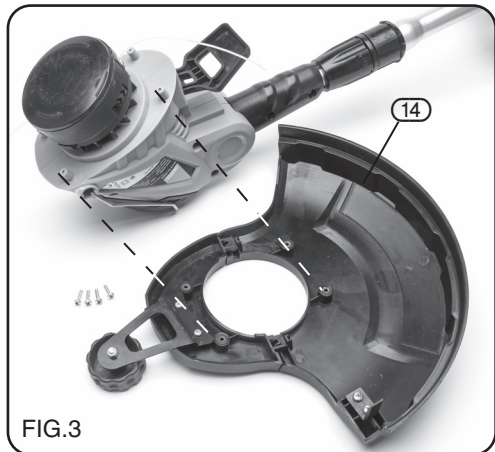

# 8. ASSEMBLY

## 8.3 AUXILIARY HANDLE - FIG. 5

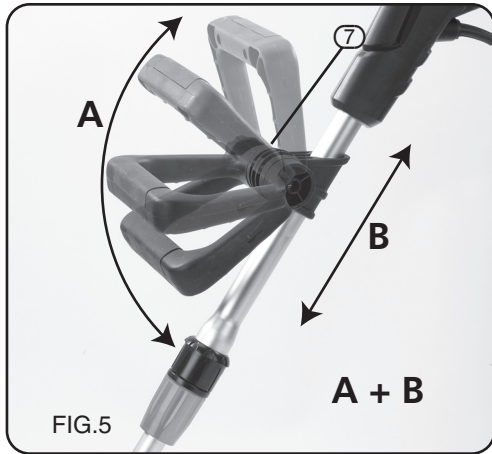

## 8.4 SHAFT LENGTH - FIG. 6

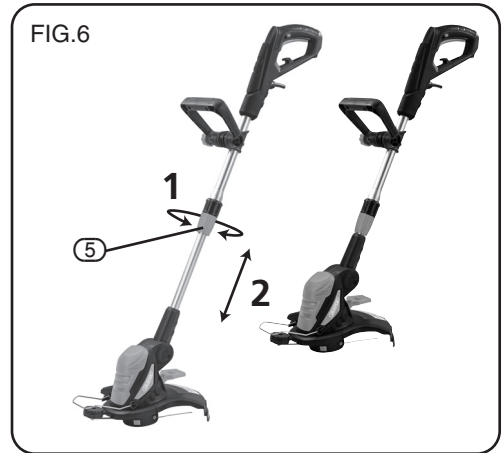

## 8.5 HEAD ROTATION - FIG. 7

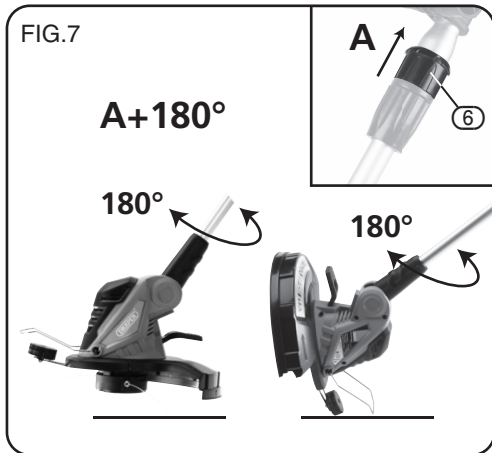

## 8.6 HEAD ANGLE - FIG. 8

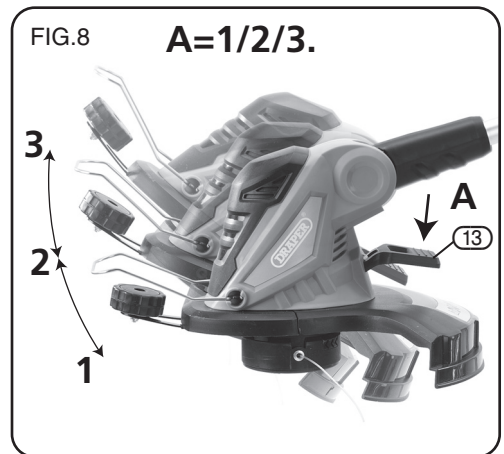

## 9. OPERATING INSTRUCTIONS



### **WARNING:**

Use of this product can pose a danger to wildlife. Before attempting to use this product check the area, particularly long grass and under bushes, for signs of life and relocate if necessary.

**NOTE:** Not all animals will be deterred by the noise of the product alone.

**Warning: The cutting head and line continue to rotate after the motor is switched off. Always keep bystanders away.**

Remove the plug from the socket before carrying out adjustment, servicing or maintenance.

### 9.1 ON/OFF TRIGGER SWITCH - FIG. 9

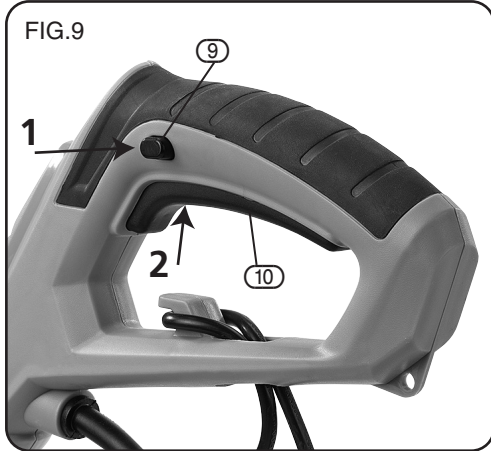

It is highly recommended that this machine is used in conjunction with an RCD (Residual current device).

# 9. OPERATING INSTRUCTIONS

## 9.2 FLOWER GUARD - FIGS. 10 - 11

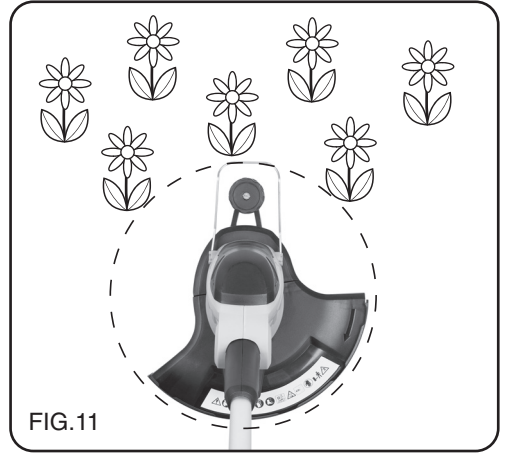
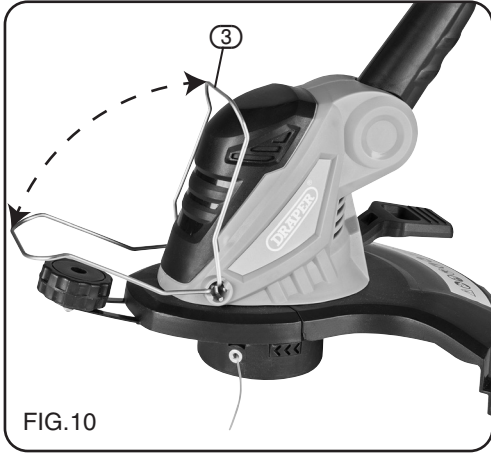

## 9.3 GUIDE WHEEL FOR EDGING - FIGS. 12 - 13

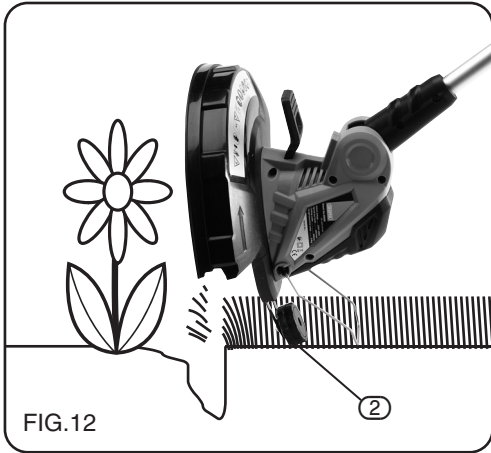

OR

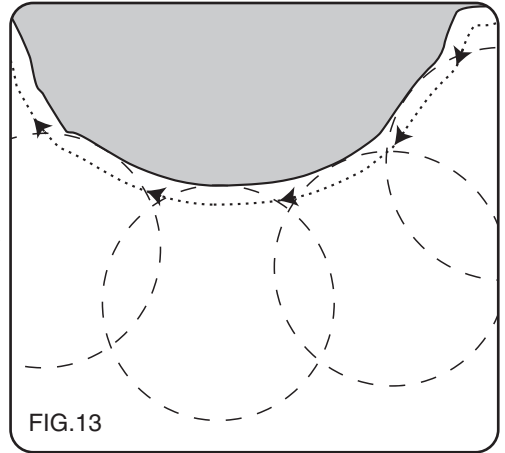

## 9. OPERATING INSTRUCTIONS

### 9.4 CUTTING HEAD - FIGS. 14 - 16

Check the nylon line regularly, when the trimming performance decreases adjust the line length.

Remove the plug from the power supply and turn the machine over. Press button (1.1) completely. Pull the nylon line one stage. Repeat this for the second line.

If the nylon line has disappeared inside the spool, proceed by pressing in the two locking tabs (1.2) simultaneously. Raise the cover up to access the reel. Take care if the reel contains any residual nylon line as it will have a tendency to uncoil rapidly. This will lead to the line becoming tangled causing feed problems. Pass the end of the line through the spool apertures and position the reel over the spring. While holding the reel down and preventing it from spinning, relocate the cover ensuring the tabs (1.2) lock on both sides.

Clean the line length trimming blade (4) of grass to ensure a satisfactory cut is maintained. After adjusting the trimming line length exercise caution as you turn on the machine as the line will be automatically cut to length to remove any excess line. This can result in debris being ejected from the cutting head area as the excess line is removed by the line length trimming blade/pin.

### 9.5 GENERAL CUTTING ACTION:

Sweep the trimmer from side to side consistently to cut small patches of grass/weed. This trimmer is not suitable and is not designed to cut large areas of lawn.

When operating the trimmer observe what direction the debris is ejected and position the trimmer to avoid injury from stones etc.

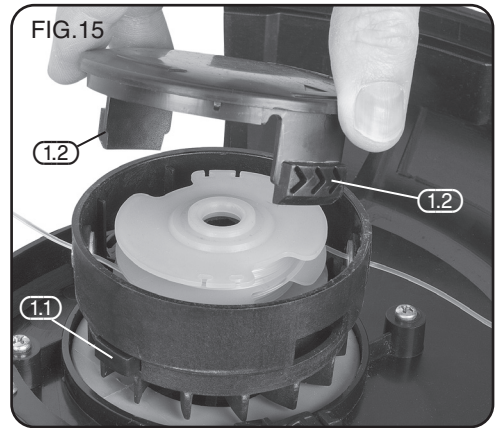
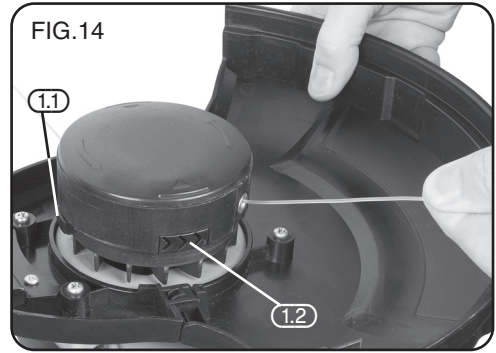

# 10. MAINTENANCE & PARTS REPLACEMENT

---

## 10.1 MAINTENANCE & PARTS REPLACEMENT

Regular inspection and cleaning reduces the necessity for maintenance operations and will keep your machine in good working condition. For this reason avoid the air inlets from becoming blocked. After use disconnect the machine from the power supply and clean the ventilation slots. Clean the line length trimming blade of grass to ensure a satisfactory cut is maintained.

**WARNING:**

Take care of injury from any device fitted for trimming the filament line length.

If the replacement of the supply cord is necessary, this has to be done by the manufacturer or his agent in order to avoid a safety hazard.



# 11. EXPLANATION OF SYMBOLS

---

## 11.1 EXPLANATION OF SYMBOLS



**WEEE**  
Do not dispose of Waste Electrical & Electronic Equipment in with domestic rubbish



Keep hands away from blades and moving parts.



Class II construction  
(Double insulated)



Remove plug before maintenance.



Warning!  
Wear suitable eye/face protection.



Wear protective gloves.



Warning!  
Can pose a danger to wildlife.



Safety shoes.



Warning!  
Read instruction manuals before operating and servicing this equipment.



Conforms to all relevant safety standards.



Beware sharp blades.



Keep distance of persons.  
Observe.



# 12. DISPOSAL

---

## 12.1 DISPOSAL

- At the end of the machine's working life, or when it can no longer be repaired, ensure that it is disposed of according to national regulations.
- Contact your local authority for details of collection schemes in your area.

In all circumstances:

- Do not dispose of power tools with domestic waste.
- Do not incinerate.
- Do not abandon in the environment.
- Do not dispose of WEEE\* as unsorted municipal waste.



\* Waste Electrical & Electronic Equipment.



## CONTACTS

- **DRAPER TOOLS LIMITED**,  
Hursley Road, Chandler's Ford,  
Eastleigh, Hampshire. SO53 1YF. U.K.
- **Help Line:** (023) 8049 4344
- **Sales Desk:** (023) 8049 4333
- **General Enquiries:** (023) 8026 6355
- **Service/Warranty Repair Agent**  
For aftersales servicing or warranty repairs, please contact the Draper Tools Help Line for details of an agent in your local area.

YOUR DRAPER STOCKIST

RDLJ1216

