

**DRAPER**

**EN**

Original Instructions  
Version 2 - 10/24

12L

# **KNAPSACK PRESSURE SPRAYER**

63056



**UK  
CA** **CE**

## 1.1 Intended Use

This product is designed to be used for spraying water, herbicides, pesticides and solvent free preservative treatments.

Any other application beyond the conditions established for use will be considered misuse. Draper Tools accepts no responsibility for improper use of this product.

Read this manual in full before using this product and retain it for future use. Always use the latest version of the manual. Please visit [drapertools.com/manuals](http://drapertools.com/manuals) for the latest version.

## 1.2 Specification

Stock No.	63056
Part No.	PS12K
Working Capacity	12L
Flexible hose	1.2M

# 2. Health and Safety Information

**Important:** Read all the Health and Safety instructions before attempting to operate or maintain this product. Failure to follow these instructions may result in injury or damage to the user or the product.

- Always follow the chemical manufacturer's instructions printed on their product labelling for use, cleaning, and storage.
- Store chemicals out of the reach of children.
- **ALWAYS** wear suitable personal protective equipment (PPE) including eye protection and gloves.
- **NEVER** open the pump when under pressure.
- **DO NOT** leave the sprayer exposed to heat sources or intense cold.
- **DO NOT** use for spraying food products such as wine, milk etc.
- **DO NOT** spray toxic or harmful liquids on persons, animals or food stuffs.
- **DO NOT** eat, drink or smoke while operating the sprayer.
- **DO NOT** spray on windy days.
- Wash hands and face after use.
- **DO NOT** leave sprayer within the reach of children.
- Keep bystanders away while using the sprayer.

## 3.1 Product Overview



- (1) Nozzles (×3)
- (2) Pump lever arm
- (3) Lance + Pump lever arm support
- (4) Trigger assembly
- (5) Lance
- (6) Pump piston
- (7) Hose

- (8) Filler cap
- (9) Integral filter
- (10) Tank
- (11) Strap buckles
- (12) Strap + adjustment clips
- (16) Safety pressure valve

# 3. Identification and Unpacking

## 3.2 What's in the Box?

Carefully remove the product from the packaging and examine it for any signs of damage that may have occurred during shipment.

Before assembling the product, lay the contents out and check them against the parts shown below. If any part is damaged or missing, do not attempt to use the product. Please contact the Draper Helpline; contact details can be found at the back of this manual.

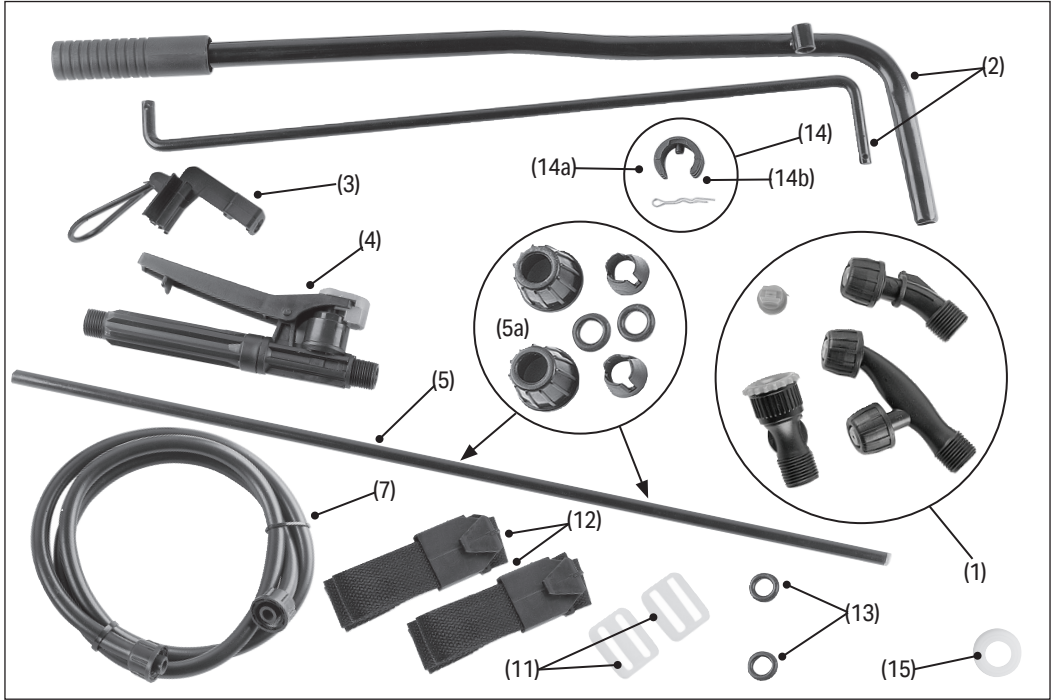

- (5a) Connectors for lance (5) (supplied fitted)
- (13) 2 × spare 'O' rings - for nozzles (1) and lance (5)
- (14) Pump lever/piston fittings
  - (14a) – 4 × Split pins (3 spare supplied) (Fig.6)
  - (14b) – clip (fig.9)
- (15) Spare pump end cover (Refer to section 6.3)

Please visit [drapertools.com](http://drapertools.com) for our full range of accessories and consumables.

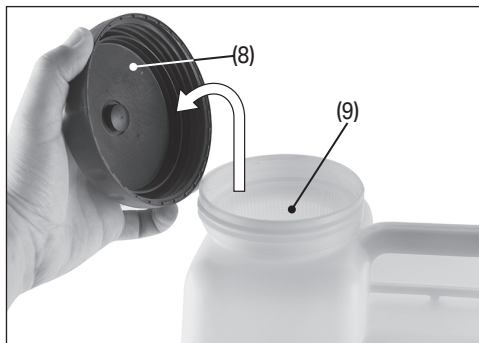

Fig. 1



Fig. 4

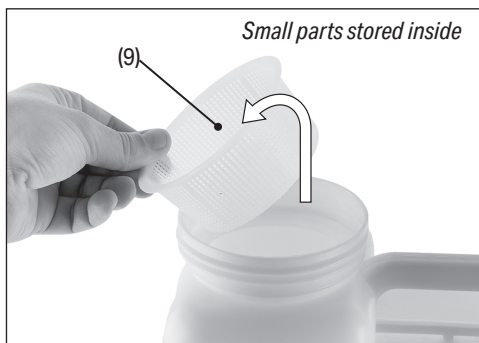

Fig. 2

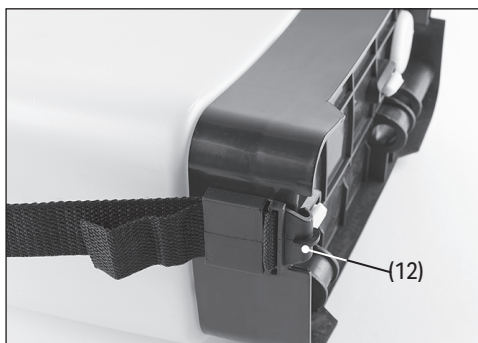

Fig. 5



Fig. 3

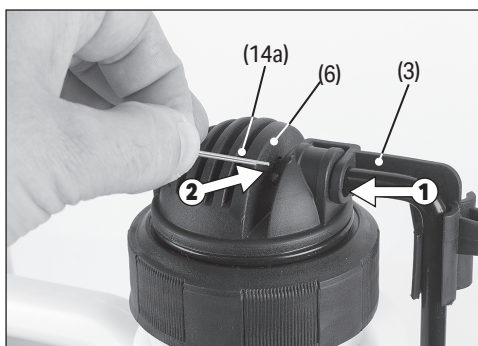

Fig. 6

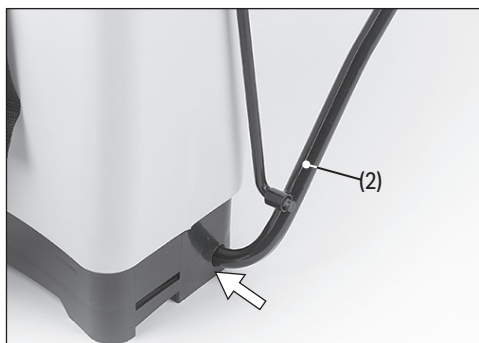

Fig. 7



Fig. 10



Fig. 8

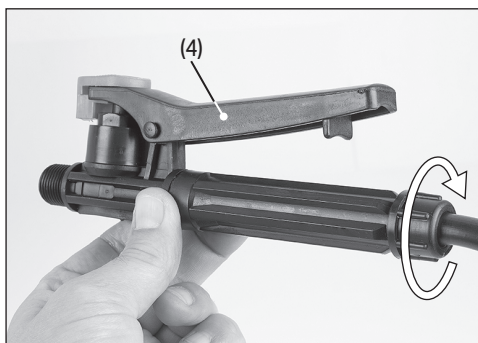

Fig. 11

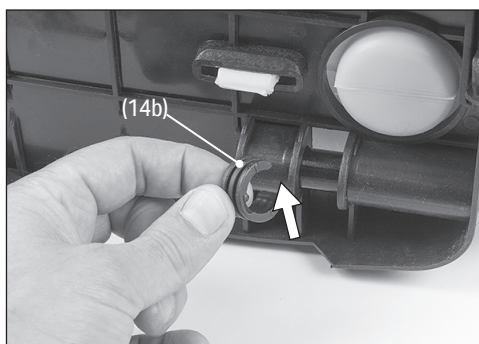

Fig. 9

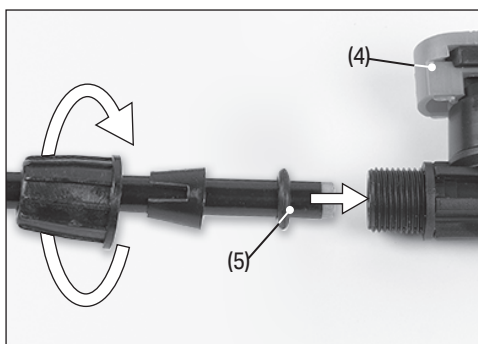

Fig. 12

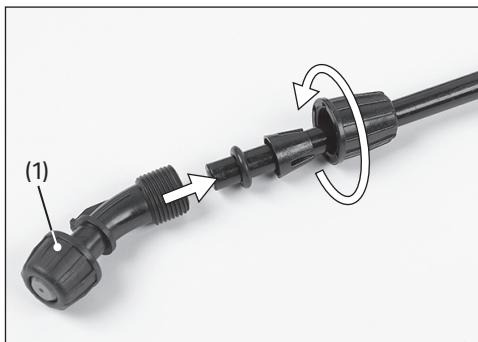

Fig. 13



Fig. 14

# 5. Operation and Use



Fig. 15



Fig. 17



Fig. 16

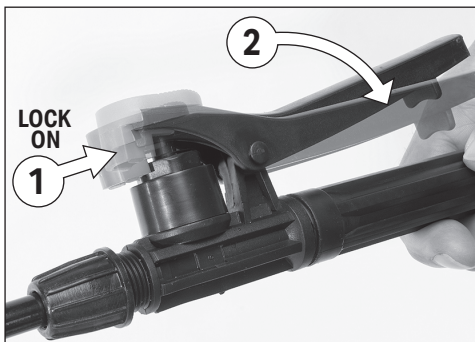

Fig. 18

At least once a year clean pump thoroughly, re-grease or lubricate all moving parts.



**WARNING! When assembling and servicing, carefully insert the pump piston without forcing, so as not to damage the gasket.**

### 6.1 Cleaning the Backpack Sprayer

1. Press the trigger on the sprayer handle to release the pressure remaining through the lance.
2. Unscrew tank cap, if the outside of the cap is dirty, thoroughly clean the area around the thread and thread O-ring.
3. Clean the inlet filter and tank cap in clean water.
4. Empty the tank and fill with clean water (with detergent added to the water if necessary).
5. Spray the water out of the backpack sprayer until the tank is empty to clean the nozzle and valves.
6. Leave the backpack sprayer open and allow it to dry.

### 6.2 Cleaning the Sprayer Handle Filter

- Unscrew the union nut and pull the hose with the filter out of the sprayer handle.
- Rinse the filter under running water and reattach the sprayer handle.

### 6.3 Cleaning the Pump

- Clean the pump if it does not provide pressure after cleaning your backpack sprayer
1. Unscrew the green locking ring from the tank and pull out the pump piston (6).
  2. Inspect the pump piston and clean with water (and detergent).
  3. Reassemble the pump.

**Note:** A spare plastic end cover (15) is supplied in case it requires replacing.

At the end of its working life, dispose of the product responsibly and in line with local regulations. Recycle where possible.

## 7. Warranty

12 months - Visit [drapertools.com/warranty](https://www.drapertools.com/warranty) for full details.

### Contact Details

#### Draper Tools

Draper Tools Limited  
Hursley Road  
Chandler's Ford  
Eastleigh  
Hampshire  
SO53 1YF  
UK

**Website:** [drapertools.com](https://www.drapertools.com)

**Email:** [sales@drapertools.com](mailto:sales@drapertools.com)

**Product Helpline:** +44 (0) 23 8049 4344

**Telephone Sales Desk:** +44 (0) 23 8049 4333

**General Enquiries:** +44 (0) 23 8026 6355

#### Delta International

Delta International BV  
Oude Graaf 8  
6002 NL  
Weert  
Netherlands

Please contact the Draper Tools Product Helpline for repair and servicing enquiries.