



DRAPER[®]

ROLLER STAND

70273



These instructions accompanying the product are the original instructions. This document is part of the product, keep it for the life of the product passing it on to any subsequent holder of the product. Read all these instructions before assembling, operating or maintaining this product.

This manual has been compiled by Draper Tools describing the purpose for which the product has been designed, and contains all the necessary information to ensure its correct and safe use. By following all the general safety instructions contained in this manual, it will ensure both product and operator safety, together with longer life of the product itself.

All photographs and drawings in this manual are supplied by Draper Tools to help illustrate the operation of the product.

Whilst every effort has been made to ensure the accuracy of information contained in this manual, the Draper Tools policy of continuous improvement determines the right to make modifications without prior warning.

1. INTRODUCTION

1.1 SCOPE

For use with bandsaws and planer/thicknesser machines where additional support of lengthy work pieces is required. Any application other than that it was designed for is considered misuse.

1.2 SPECIFICATION

Stock No.	70273
Part No.	RST310A
Roller length	282mm
Min. stand height	670mm
Max. stand height	1060mm
Max. supporting weights:	
670mm	60kg
1060mm	30kg
Weight (nett)	4kg

1.3 HANDLING AND STORAGE

- Care must be taken when handling this product.
 - Dropping this tool could have an effect on its accuracy and could also result in personal injury. This product is not a toy and must be respected.
- Environmental conditions can have a detrimental effect on this product if neglected.
 - Exposure to damp air can gradually corrode components. If the product is unprotected from dust and debris, components will become clogged.
 - If not cleaned and maintained correctly or regularly, the machine will not perform at its best.

2. ASSEMBLY

2.1 ASSEMBLY

- Attach feet (Fig. 1).
- Connect folding leg (Fig. 2).
- Slide extending arm.
- Screw in adjustment handle.
- Attach roller head (Fig. 3).

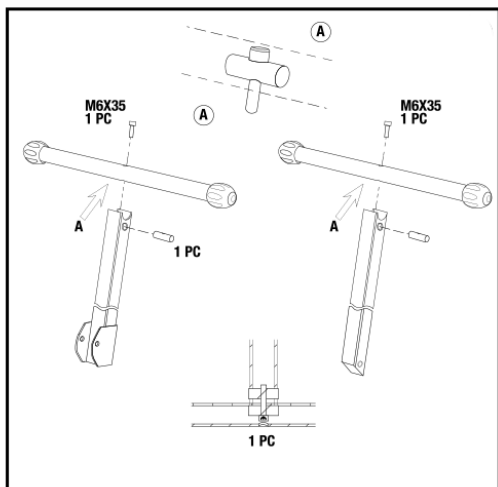

Fig. 1

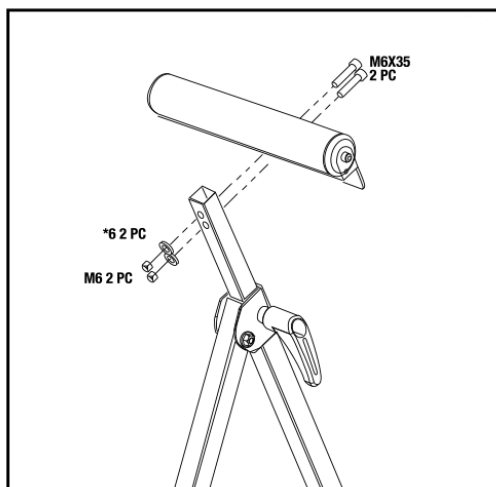

Fig. 3

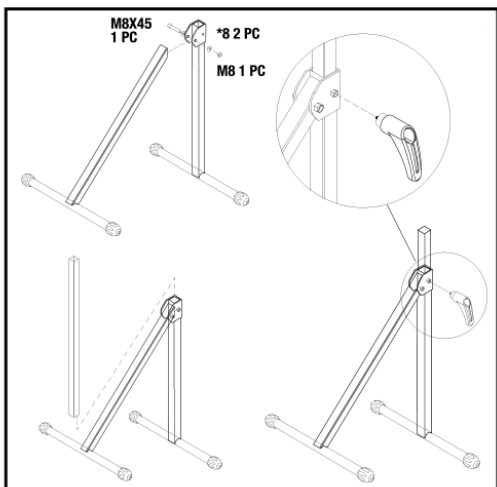

Fig. 2

CONTACTS

Draper Tools Limited, Hursley Road,
Chandler's Ford, Eastleigh, Hampshire. SO53 1YF. U.K.

Help Line: (023) 8049 4344

Sales Desk: (023) 8049 4333

Internet: drapertools.com

E-mail: sales@drapertools.com

General Enquiries: (023) 8026 6355

Service/Warranty Repair Agent:

For aftersales servicing or warranty repairs, please contact the Draper Tools Help Line for details of an agent in your local area.

YOUR DRAPER STOCKIST

RDCM1020

©Published by Draper Tools Limited.

No part of this publication may be reproduced, stored in a retrieval system or transmitted in any form or by any means, electronic, mechanical photocopying, recording or otherwise without prior permission in writing from Draper Tools Ltd.