

EN

Original Instructions
Version 1

DRAPER[®]

600MM FOLD DOWN **WORKBENCH**

77020



UK
CA **CE**

These are the original product instructions. This document is part of the product; retain it for the life of the product, passing it on to subsequent holders. Read this manual in full before attempting to assemble, operate, or maintain this product.

This Draper Tools manual describes the purpose of the product and contains all the necessary information to ensure its correct and safe use. Following all the instructions and guidance in this manual will ensure the safety of both the product and the operator and increase the lifespan of the product.

All photographs and drawings within this manual are supplied by Draper Tools to help illustrate correct operation of the product.

Every effort has been made to ensure the information contained in this manual is accurate. However, Draper Tools reserves the right to amend this document without prior warning. Always use the latest version of the product manual.

1.1 Product Reference

User Manual for: 600mm Fold Down Workbench

Stock No: 77020

Part No: WB600Y

1.2 Revisions

Version 1: August 2012

First release

Version 2: April 2021

General content and formatting updates

Version 3: July 2022

General content revision

As our manuals are continually updated, always ensure that the latest version is used.

Download the latest version from:

drapertools.com/manuals

1.3 Understanding the Safety Content of This Manual

WARNING! – Situations or actions that may result in personal injury or death.

CAUTION! – Situations or actions that may result in damage to the product or surroundings.

Important: – Information or instructions of particular importance.

1.4 Copyright © Notice

Copyright © Draper Tools Limited.

Permission is granted to reproduce this manual for personal and educational use **ONLY**. Commercial copying, redistribution, hiring, or lending is strictly prohibited.

No part of this manual may be stored in a retrieval system or transmitted in any other form or means without written permission from Draper Tools Limited.

In all cases, this copyright notice must remain intact.

1. Preface	2
1.1 Product Reference	2
1.2 Revisions	2
1.3 Understanding the Safety Content of This Manual	2
1.4 Copyright © Notice	2
2. Contents	3
3. Warranty	4
4. Product Introduction	5
4.1 Scope	5
4.2 Specification	5
5. Health and Safety Information	6
5.1 General Health and Safety Instructions	6
6. Identification and Unpacking	7
6.1 Product Overview	7
6.2 What's in the Box?	8
7. Assembly Instructions	9
7.1 Assemble the Legs	9
7.2 Attach the Top Frames	9
7.3 Attach the Crossbars	10
7.4 Attach the U-Brackets to the Top Frames	10
7.5 Attach the Benchtops	12
7.6 Finishing Touches	12
8. Operating Instructions	13
8.1 Unfolding and Folding the Workbench	13
8.2 Clamping a Workpiece	13
9. Storage, Spares and Disposal	14
10. Explanation of Symbols	15

3. Warranty

Draper Tools products are carefully tested and inspected before shipment and are guaranteed to be free from defective materials and workmanship.

Should the tool develop a fault, return the complete tool to your nearest distributor or contact Draper Tools directly. Contact information can be found at the back of this manual.

Proof of purchase must be provided.

If, upon inspection, it is found that the fault occurring is due to defective materials or workmanship, repairs will be carried out free of charge. This warranty period covers parts and labour for 12 months from the date of purchase. Where tools have been hired out, the warranty period covers 90 days from the date of purchase.

This warranty does not apply to any consumable parts, batteries or normal wear and tear, nor does it cover any damage caused by misuse, careless or unsafe handling, alterations, accidents, or repairs attempted or made by any personnel other than the authorised Draper Tools repair agent.

In all cases, to make a claim for faulty workmanship or materials within the standard warranty period, please contact or return the product to the place of purchase. Proof of purchase may be required.

If the place of purchase is no longer trading or if you experience any difficulties with your warranty, please contact Customer Services with the product details and your proof of purchase. Contact details can be found at the back of this manual.

If the tool is not covered by the terms of this warranty, repairs and carriage charges will be quoted and charged accordingly.

This warranty supersedes any other guarantees expressed or implied and variations of its terms are not authorised.

Your Draper Tools guarantee is not effective until you can produce, upon request, a dated receipt or invoice to verify your purchase within the guarantee period.

Please note that this warranty is an additional benefit and does not affect your statutory rights.

Draper Tools Limited

4. Product Introduction

EN

4.1 Scope

This folding workbench is designed for use as a portable work surface and saw horse with customisable clamping arrangements. Any other application beyond the conditions established for use will be considered misuse. Draper Tools accepts no responsibility for improper use of this product.

Part of our core range, this product is suitable for regular use by enthusiasts and tradespersons alike.

WARNING! This product is not a toy and must be respected.

Read this manual in full before attempting to assemble, operate or maintain the product, and retain it for later use.

4.2 Specification

Stock No.	77020
Part No.	WB600Y
Dimensions:	
Folded:	W 605 x H 950 x D 240mm
Unfolded:	W 605 x H 785 x D 640mm
Max. clamping width:	260mm
Max. load capacity:	100kg (evenly distributed)
Net weight:	6.7kg

Important: Read all Health and Safety instructions before attempting to operate, maintain or repair this product. Non-compliance with these instructions may result in injury or damage to the user or the product.

5.1 General Health and Safety Instructions

- Observe all standard safety precautions and good practices when in a workshop environment.
- Read all the safety information associated with any tools to be used in conjunction with this workbench.
 - Use all appropriate personal protective equipment when working with tools.
 - Be mindful that tools that may damage the workbench frame or work surface if used carelessly.
- Before every use, inspect the workbench for broken, cracked, loose or corroded parts.

Important: DO NOT use this product if it is damaged or its structural integrity is compromised. Contact Draper Tools to discuss repair and replacement options.
- Ensure that the workbench is fully assembled, opened and tightened before use, with the folding braces locked in place.
- Ensure that the workbench is positioned on firm and level ground while it is in use.
 - **DO NOT** use the workbench on slippery or wet surfaces.
- **DO NOT** climb or stand on the workbench.
- **DO NOT** exceed the rated weight limit.
 - **DO NOT** store heavy loads on the workbench for extended periods.
- Position the workpiece so that the weight is evenly distributed and does not overbalance the workbench.
- **NEVER** clamp or mount tools to the workbench.
- **DO NOT** expose the product to rain or wet environments.
- Take care when lifting or moving the workbench.

CAUTION! DO NOT overtighten the clamps.

6.1 Product Overview

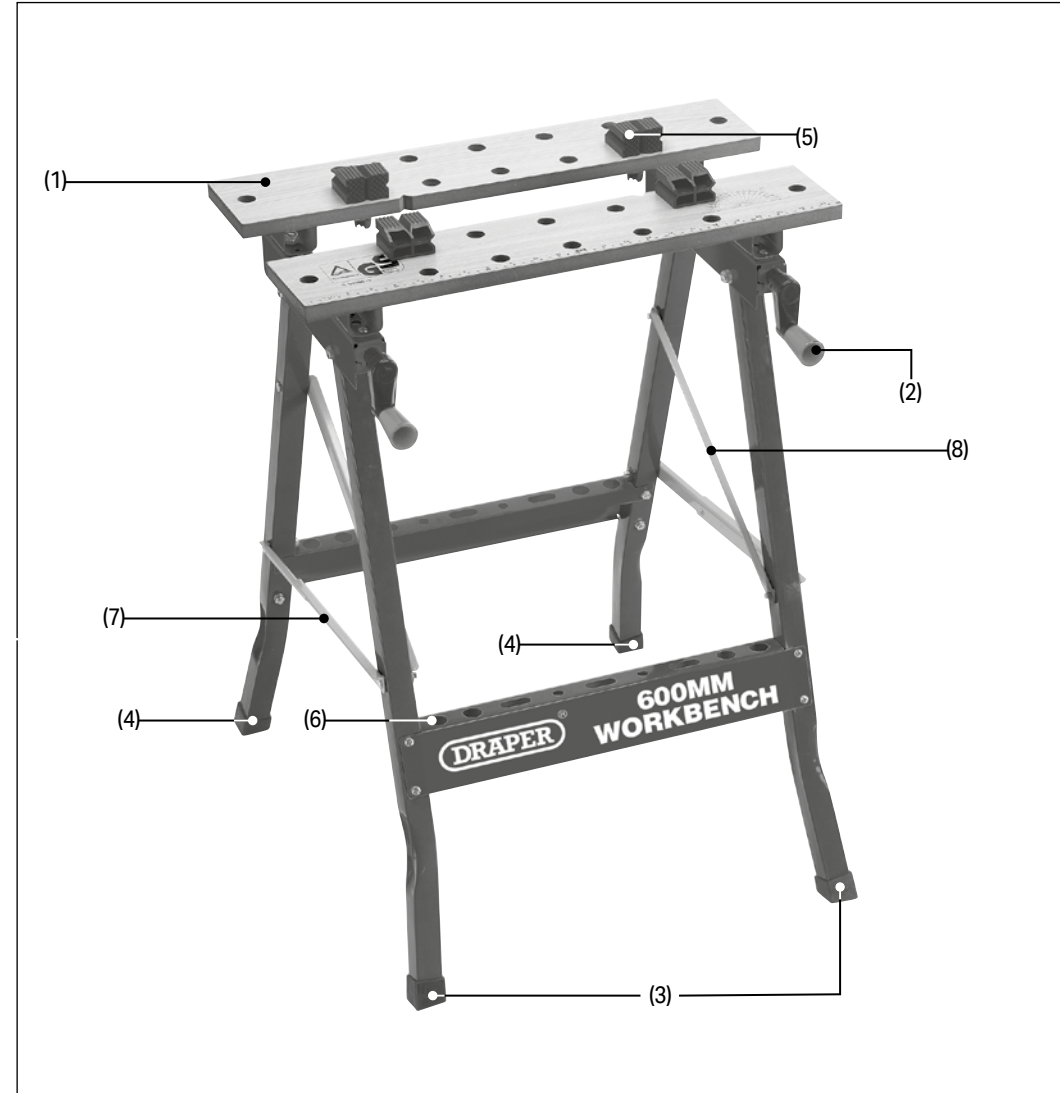

- | | |
|-------------------|---------------------|
| (1) Benchtop | (5) Clamp blocks |
| (2) Crank handles | (6) Tool holders |
| (3) Front legs | (7) Folding braces |
| (4) Rear legs | (8) Diagonal braces |

6.2 What's in the Box?

Carefully remove the product from the packaging and examine it for any signs of damage that may have occurred during shipment.

Before assembling the product, lay the contents out and check them against the parts shown below. If any part is damaged or missing, do not attempt to use the product. Please contact the Draper Tools Helpline; contact details can be found at the back of this manual.

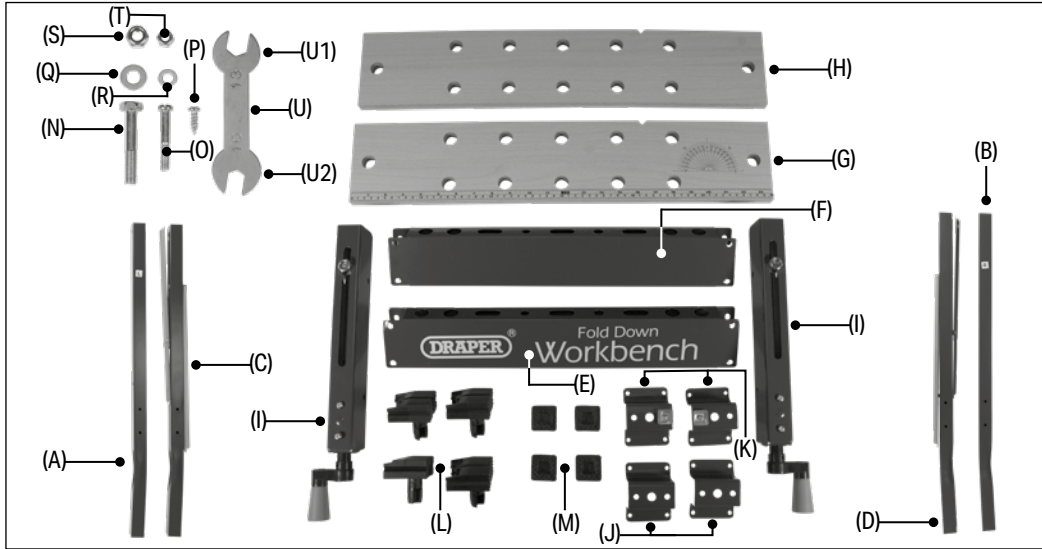

- | | |
|--------------------------------------|---|
| (A) 1 x Front left leg | (M) 4 x Feet |
| (B) 1 x Front right leg | (N) 6 x M8 x 45mm half-thread hex bolts |
| (C) 1 x Rear left leg | (O) 8 x M6 x 37mm half-thread screws |
| (D) 1 x Rear right leg | (P) 16 x M5 x 16mm self-tapping screws |
| (E) 1 x Front crossbar | (Q) 12 x M8 washers |
| (F) 1 x Rear crossbar | (R) 8 x M6 washers |
| (G) 1 x Front benchtop | (S) 6 x M8 nylon-insert lock nuts |
| (H) 1 x Rear benchtop | (T) 8 x M6 nylon-insert lock nuts |
| (I) 2 x Top frames | (U) 1 x Spanner tool |
| (J) 2 x U-brackets (bare) | U1. M8 spanner |
| (K) 2 x U-brackets with guide plates | U2. M6 spanner |
| (L) 4 x Clamp blocks | |

6.3 Packaging

Keep the product packaging for the duration of the warranty period for reference should the product need to be returned for repair.

WARNING! Keep packaging materials out of reach of children. Dispose of packaging correctly and responsibly and in accordance with local regulations.

Please visit drapertools.com for our full range of accessories and consumables.

Important: Read and understand all the safety instructions listed in this manual before attempting to assemble this product.

Important: Ensure all bolts are only **FINGER TIGHT** until assembly is complete. Then tighten all fixtures securely.

7.1 Assemble the Legs

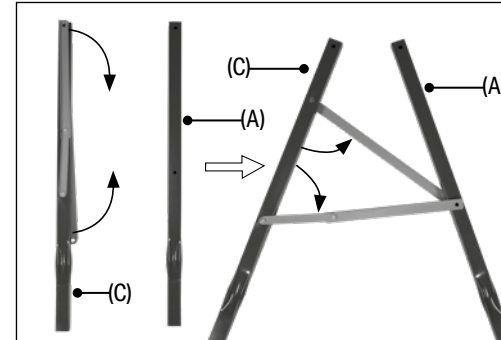

Fig. 1

- Place the rear **left** leg (C) on your left and the front left leg (A) on your right so that the indented sides are at the bottom and facing **towards** you.
Important: The folding brace should also be facing **towards** you.
- Open the folding brace (7) and the diagonal brace (8) and align them with the hole halfway up the left front leg.
Important: The leg should be positioned between the two braces, with the lipped edges of the braces facing upward. The folding leg should be able to fold upward.

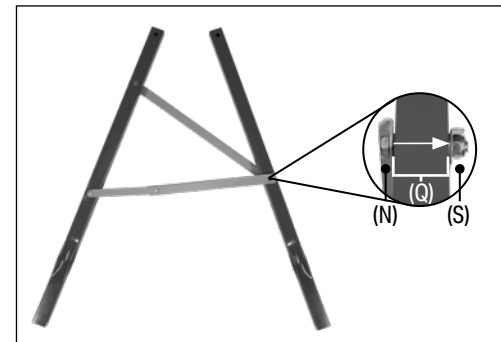

Fig. 2

- Pass an M8 x 45mm half-thread hex bolt (N) through both braces and the leg and secure them in place with an M8 nylon-insert lock nut (S).
Important: Place an M8 washer (Q) between each brace and the leg to ensure smooth folding.

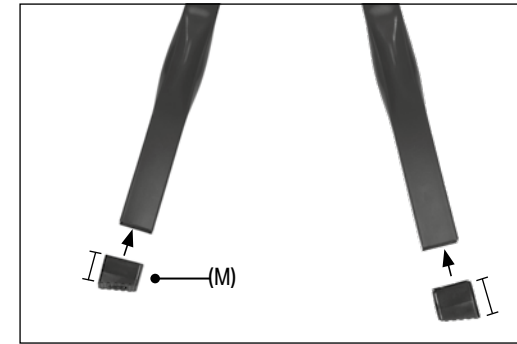

Fig. 3

- Attach a foot (M) to the indented end of each leg so that the longest edge is positioned outwardly on the same side as the folding brace.
- Repeat these steps for the front right (B) and rear right (D) legs, with the rear leg on your **left** and the front leg on your **right**.

7.2 Attach the Top Frames

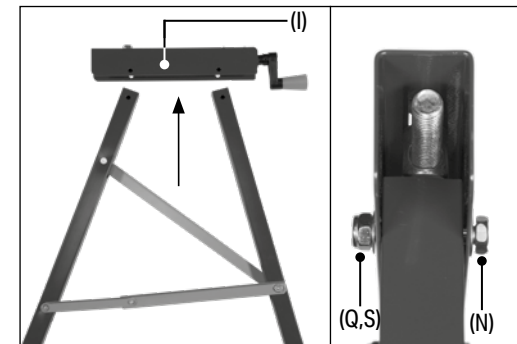

Fig. 4

- Insert the upper ends of the **left** leg assembly between the brackets of a top frame (I) so that the holes align and the crank handle (2) is positioned above the front leg (A).
- Pass two M8 x 45mm half-thread hex bolts (N) each through an M8 washer (Q) and top frame bracket around the leg and secure each in place with another M8 washer and an M8 nylon-insert lock nut (S).
- Repeat these steps for the right leg assembly, ensuring that the crank handle is positioned over the **front** leg.

7.3 Attach the Crossbars

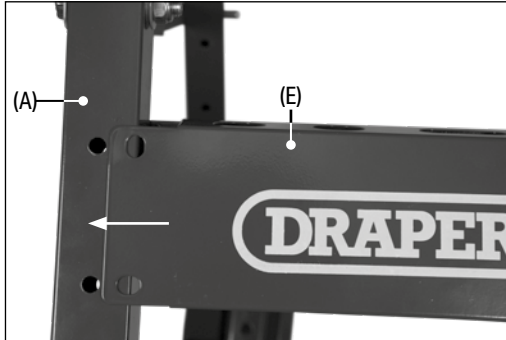

Fig. 5

1. Insert the front **left** leg (A) between the left brackets of the front crossbar (E) so that the holes align.
Important: The crossbar brackets can be shaped to fit comfortably around the leg as required.
2. Pass two M6 x 37mm half-thread screws (O) through the front crossbar brackets around the front left leg and secure each in place with an M6 washer (R) and an M6 nylon-insert lock nut (T).



Fig. 6

3. Insert the front **right** leg (B) between the **right** brackets of the front crossbar so that the holes align.
4. Pass two M6 x 37mm half-thread screws (O) through the front crossbar brackets around the front right leg and secure each in place with an M6 washer (R) and an M6 nylon-insert lock nut (T).



Fig. 7

5. Place the rear crossbar (F) between the rear legs and align the holes.
6. Secure the rear crossbar in place using four M6 x 37mm half-thread screws (O), M6 washers (R) and M6 nylon-insert lock nuts (T).
Important: Once assembled, the legs should bend outwards slightly at the bottom to improve the stability of the workbench.

7.4 Attach the U-Brackets to the Top Frames

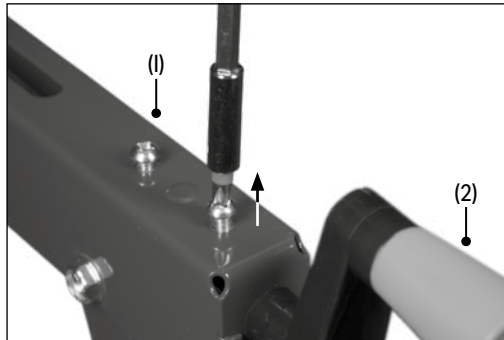

Fig. 8

1. Remove the two screws near the crank handle (2) in the left top frame.

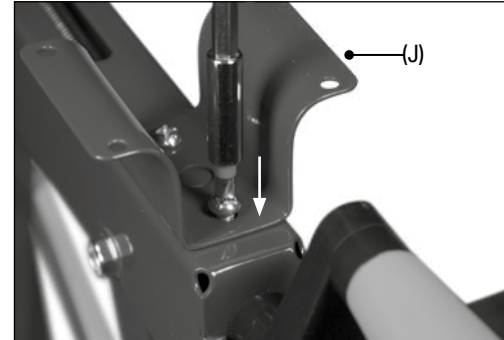

Fig. 9

2. With the bracket arms extended upwards, align a bare U-bracket (J) with the holes and screw it into place.

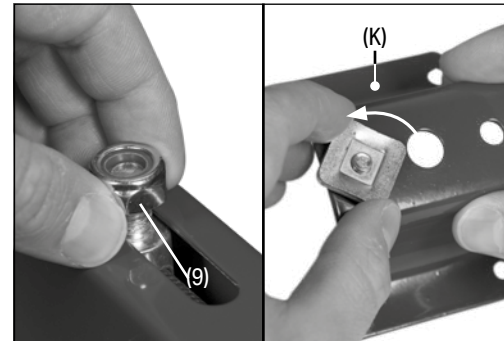

Fig. 10

3. Unscrew the M10 nut (9) from the left top frame and unscrew the plate from a U-bracket with guide plate (K).
4. Place the centre hole of the U-bracket over the M10 bolt in the top frame so that the bracket arms extend upwards and the two smaller holes are positioned above the slot.

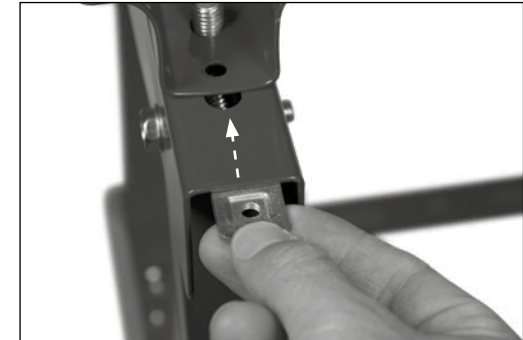

Fig. 11

5. Slide the guide plate under the top of the top frame and pass the screw down through the U-bracket to secure it into place.



Fig. 12

6. Replace the M10 nut above the U-bracket.
Important: DO NOT overtighten the guide plate screw or M10 nut as this will stop the crank handle from operating smoothly.
7. Repeat these steps for the right top frame.

7.5 Attach the Benchtops

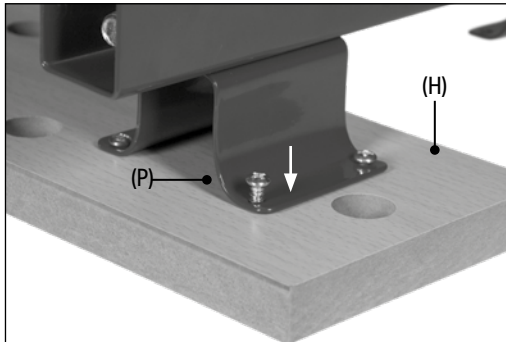

Fig. 13

1. Place the rear benchtop (H) onto the rear U-brackets so that the eight small holes align with the brackets and the notch is on the inside edge.
2. Screw eight M5 x 16mm self-tapping screws (P) up through the brackets and into the benchtop.

Important: **LOOSELY** insert all eight screws before tightening them to ensure that all of the holes align correctly.



Fig. 14

3. Repeat these steps for the front benchtop (G), keeping the ruled edge towards the crank handles.

7.6 Finishing Touches

Important: The nylon inserts inside the nuts should be broken when securely tightened. This provides additional security against the accidental loosening of bolts during use.

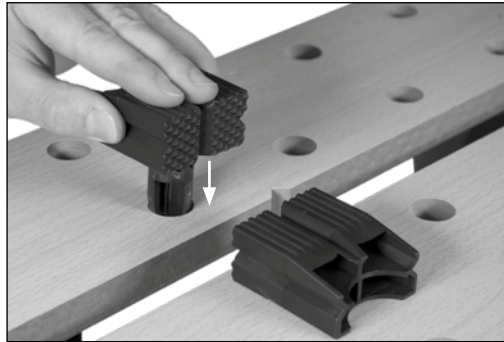

Fig. 15

Important: When complete, the folding braces between the front and rear legs should be on the outside of the frame and should fold upwards when the workbench is closed.

Important: Before using this product, read and understand all the safety instructions listed in this manual.

8.1 Unfolding and Folding the Workbench

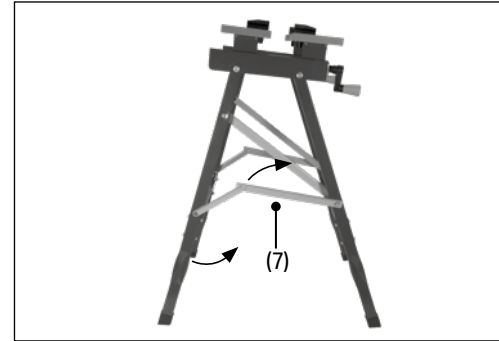

Fig. 16

1. To unfold the workbench:
 - a. Pull the front and rear legs apart.
 - b. Press down on the folding braces (7) to lock the legs in position.
2. To fold the workbench away:
 - a. Ensure that the crank handles are not in the downward position so as not to damage or obstruct the legs when folding.
 - b. Lift the folding braces (7) upwards to unlock the legs.
 - c. Push the front and rear legs together until the workbench is fully closed.

8.2 Clamping a Workpiece

Workpieces can be clamped directly between the benchtop pieces or between the clamp blocks. The clamp blocks can be repositioned as required to accommodate workpieces of varying shapes and sizes. The notches in the benchtop pieces can be used to grip pipes and tubing.

1. Position the clamp blocks (5) in the appropriate holes of the benchtop as required.
2. Use the crank handles (2) to separate or bring together the benchtop pieces as appropriate to grip the workpiece:
 - To separate the benchtop pieces, turn both crank handles anticlockwise.
 - To bring the benchtop pieces together, turn both crank handles clockwise.

Important: Adjust both crank handles together to open or close the benchtop evenly.

The crossbars may be used to store tools.

9. Storage, Spares and Disposal

EN

Store the workbench in a clean and dry location, out of direct sunlight and out of reach of children.

Important: DO NOT store heavy loads on the workbench for extended periods.

For spare parts, servicing, and repair and replacement options, please contact the Draper Tools Product Helpline for details of your nearest authorised agent.

Draper Tools will endeavour to hold any spare parts, if applicable, for seven years from the date that it sells the final matching stock item.

Any servicing or repairs carried out by unauthorised personnel or installation of spare parts not supplied by Draper Tools will invalidate your warranty.

At the end of its working life, dispose of the product responsibly and in line with local regulations. Recycle where possible.

10. Explanation of Symbols

EN



Read the instruction manual

Contact Details

Draper Tools

Draper Tools Limited
Hursley Road
Chandler's Ford
Eastleigh
Hampshire
SO53 1YF
UK

Website: drapertools.com

Email: sales@drapertools.com

Product Helpline: +44 (0) 23 8049 4344

Telephone Sales Desk: +44 (0) 23 8049 4333

General Enquiries: +44 (0) 23 8026 6355

General Fax: +44 (0) 23 8026 0784

Delta International

Delta International BV
Oude Graaf 8
6002 NL
Weert
Netherlands

Please contact the Draper Tools Product Helpline for repair and servicing enquiries.