



**DRAPER**<sup>®</sup>

230V  
**RECIPROCATING  
SAW**

83628



These instructions accompanying the product are the original instructions. This document is part of the product, keep it for the life of the product passing it on to any subsequent holder of the product. Read all these instructions before assembling, operating or maintaining this product.

This manual has been compiled by Draper Tools describing the purpose for which the product has been designed, and contains all the necessary information to ensure its correct and safe use. By following all the general safety instructions contained in this manual, it will ensure both product and operator safety, together with longer life of the product itself.

All photographs and drawings in this manual are supplied by Draper Tools to help illustrate the operation of the product.

Whilst every effort has been made to ensure the accuracy of information contained in this manual, the Draper Tools policy of continuous improvement determines the right to make modifications without prior warning.

# 1. TITLE PAGE

---

## 1.1 INTRODUCTION:

**USER MANUAL FOR: 230V Reciprocating Saw**

**Stock No:83628**

**Part No:RSAW900D**

## 1.2 REVISIONS:

**Date first published September 2018.**

---

---

---

---

As our user manuals are continually updated, users should make sure that they use the very latest version.

**Downloads are available from:** <http://drapertools.com/manuals>

Draper Tools Limited

Hursley Road

Chandler's Ford

Eastleigh

Hampshire

SO53 1YF

UK

**Website:** [drapertools.com](http://drapertools.com)

**Product Helpline:** +44 (0) 23 8049 4344

**General Fax:** +44 (0) 23 8026 0784

## 1.3 UNDERSTANDING THIS MANUALS SAFETY CONTENT:

**WARNING!** – Information that draws attention to the risk of injury or death.

**CAUTION!** – Information that draws attention to the risk of damage to the product or surroundings.

## 1.4 COPYRIGHT © NOTICE:

Copyright © Draper Tools Limited.

Permission is granted to reproduce this publication for personal and educational use only. Commercial copying, redistribution, hiring or lending is prohibited.

No part of this publication may be stored in a retrieval system or transmitted in any other form or means without written permission from Draper Tools Limited.

In all cases this copyright notice must remain intact.

---

## 2. CONTENTS

---

<b>1. TITLE PAGE</b>	
1.1 INTRODUCTION.....	2
1.2 REVISION HISTORY .....	2
1.3 UNDERSTANDING THIS MANUAL .....	2
1.4 COPYRIGHT NOTICE .....	2
<b>2. CONTENTS</b>	
2.1 CONTENTS.....	3
<b>3. WARRANTY</b>	
3.1 WARRANTY.....	4
<b>4. INTRODUCTION</b>	
4.1 SCOPE.....	5
4.2 SPECIFICATION .....	5
4.3 HANDLING AND STORAGE.....	5
<b>5. HEALTH AND SAFETY INFORMATION</b>	
5.1 GENERAL SAFETY INSTRUCTIONS FOR POWER TOOL USE .....	6-7
5.2 SAFETY INSTRUCTIONS FOR RECIPROCATING SAWS.....	7-8
5.3 RESIDUAL RISK .....	8
5.4 CONNECTION TO THE POWER SUPPLY.....	8
<b>6. TECHNICAL DESCRIPTION</b>	
6.1 IDENTIFICATION .....	9
<b>7. UNPACKING AND CHECKING</b>	
7.1 PACKAGING .....	10
7.2 WHAT'S IN THE BOX.....	10
<b>8. PREPARING THE RECIPROCATING SAW</b>	
8.1 BLADE INSTALLATION.....	11
8.2 ADJUSTABLE FOOT.....	11
<b>9. BASIC RECIPROCATING SAW OPERATION</b>	
9.1 SWITCH AND VARIABLE STROKE RATE CONTROL.....	12
9.2 GENERAL CUTTING .....	12
9.3 FLUSH CUTTING.....	13
<b>10. OPTIONAL ACCESSORIES</b>	
10.1 OPTIONAL ACCESSORIES.....	14
<b>11. MAINTENANCE AND TROUBLESHOOTING</b>	
11.1 MAINTENANCE .....	15
11.2 TROUBLESHOOTING .....	15
<b>12. DISPOSAL</b>	
12.1 DISPOSAL.....	16
<b>13. EXPLANATION OF SYMBOLS</b>	
13.1 EXPLANATION OF SYMBOLS .....	17
<b>DECLARATION OF CONFORMITY .....</b>	<b>ENCLOSED</b>

## 3. WARRANTY

---

### 3.1 WARRANTY

Draper tools have been carefully tested and inspected before shipment and are guaranteed to be free from defective materials and workmanship.

Should the tool develop a fault, please return the complete tool to your nearest distributor or contact:

**Draper Tools Limited, Chandler's Ford, Eastleigh, Hampshire, SO53 1YF. England.**

**Telephone Sales Desk: (023) 8049 4333 or:**

**Product Helpline (023) 8049 4344.**

A proof of purchase must be provided.

If upon inspection it is found that the fault occurring is due to defective materials or workmanship, repairs will be carried out free of charge. This warranty period covering labour is 12 months from the date of purchase except where tools are hired out when the warranty period is 90 days from the date of purchase. The warranty is extended to 24 months from the date of purchase for parts only. This warranty does not apply to any consumable parts, any type of battery or normal wear and tear, nor does it cover any damage caused by misuse, careless or unsafe handling, alterations, accidents, or repairs attempted or made by any personnel other than the authorised Draper warranty repair agent.

Note: If the tool is found not to be within the terms of warranty, repairs and carriage charges will be quoted and made accordingly.

This warranty applies in lieu of any other warranty expressed or implied and variations of its terms are not authorised.

Your Draper warranty is not effective unless you can produce upon request a dated receipt or invoice to verify your proof of purchase within the warranty period.

Please note that this warranty is an additional benefit and does not affect your statutory rights.

**Draper Tools Limited.**

## 4. INTRODUCTION

---

### 4.1 SCOPE

This versatile tool is designed to cut wood, plastic and metal, including sheet materials, branches/logs and window surrounds.

As part of our core range, this product is suitable for enthusiasts and tradespeople alike. Any application other than that it was intended for, is considered misuse.

### 4.2 SPECIFICATION

Stock no.....	83628
Part no.....	RSAW900D
Motor:	
Rated voltage .....	230V~
Rated frequency .....	50Hz
Rated input .....	900W
Stroke speed (no load) .....	0-2,600s/min
Cutting capacity:	
Wood .....	115mm
Mild steel.....	8mm
Stroke length.....	20mm
Sound pressure level (LpA):.....	84.4dB(A)
Sound power level (LWA):.....	95.4dB(A)
Uncertainty (K): .....	3dB(A)
Vibration level:	
cutting boards with a sawblade .....	18.86m/s <sup>2</sup> +/-1.5m/s
cutting wooden beams with a sawblade .....	16m/s <sup>2</sup> +/-1.5m/s
Weight (nett) .....	2.80kg

### 4.3 HANDLING AND STORAGE

Care must still be taken when handling and lifting. Dropping this machine will have an effect on the accuracy and may also result in personal injury. This machine is not a toy and must be respected.

The environment will have a negative result on its operation if you are not careful. If the air is damp, components will rust. If the machine is unprotected from dust and debris; components will become clogged: And if not cleaned and maintained correctly or regularly the machine will not perform at its best.

## 5. HEALTH AND SAFETY INFORMATION

---

When using any type of power tool there are steps that should be taken to make sure that you, as the user, remain safe.

Common sense and a respect for the tool will help reduce the risk of injury.

### 5.1 GENERAL SAFETY INSTRUCTIONS FOR POWER TOOL USE

#### Warning!

- Read all safety warnings and all instructions. Failure to follow the warnings and instructions may result in electric shock, fire and/or serious injury.

**Most important:** You must know how to safely start and stop this machine, especially in an emergency.

**Keep the work area tidy and clean.** Attempting to clear clutter from around the machine during use will reduce your concentration. Mess on the floor creates a trip hazard. Any liquid spilled on the floor could result in you slipping.

**Find a suitable location.** If the machine is bench mounted, the location should provide good natural light or artificial lighting as a replacement. Avoid damp and dusty locations as it will have a negative effect on the machine's performance. If the machine is portable do not expose the tool to rain. In all cases do not operate power tools near any flammable materials.

**Keep bystanders away.** Children, onlookers and passers by must be restricted from entering the work area for their own protection. The barrier must extend a suitable distance from the tool user.

Unplug and house all power tools that are not in use. A power tool should never be left unattended while connected to the power supply. They must be housed in a suitable location, away locked up and from children.

**Do not overload or misuse the tool.** All tools are designed for a purpose and are limited to what they are capable of doing. Do not attempt to use a power tool (or adapt it in any way) for an application it is not designed for. Select a tool appropriate for the size of the job. Overloading a tool will result in tool failure and user injury: This covers the use of accessories.

**Dress properly.** Loose clothing, long hair and jewellery are all dangerous because they can become entangled in moving machinery: This can also result in parts of body being pulled into the machine. Clothing should be close fitted, with any long hair tied back and jewellery and neck ties removed. Footwear must be fully enclosed and have a non-slip sole.

**Wear personal protective equipment (PPE).** Dust, noise, vibration and swarf can all be dangerous if not suitably protected against. If the work involving the power tool creates dust or fumes wear a dust mask. Vibration to the hand, caused by operating some tools for longer periods must be protected against. Wear vibration reducing gloves and allow long breaks between uses. Protect against dust and swarf by wearing approved safety goggles or a face shield. These are some of the more common hazards and preventions, however, always find out what hazards are associated with the machine/work process and wear the most suitable protective equipment available.

**Do not breathe contaminated air.** If the work creates dust or fumes connect the machine (if possible) to an extraction system either locally or remotely. Working outdoors can also help if possible.

**Move the machine as instructed.** If the machine is hand held, do not carry it by the power supply cable. If the product is heavy, employ a second or third person to help move it safely or use a mechanical device. Always refer to the instructions for the correct method.

**Do not overreach.** Extending your body too far can result in a loss of balance and you falling. This could be from a height or onto a machine and will result in injury.

**Maintain your tools correctly.** A well maintained tool will do the job safely. Replace any damaged or missing parts immediately with original parts from the manufacturer. As applicable keep blades sharp, moving parts clean, oiled or greased, handles clean and emergency devices working.

## 5. HEALTH AND SAFETY INFORMATION

---

**Wait for the machine to stop.** Unless the machine is fitted with a safety brake, some parts may continue to move due to momentum. Wait for all parts to stop, then unplug it from the power supply before making any adjustments, carrying out maintenance operations or just finishing using the tool.

**Remove and check setting tools.** Some machinery requires the use of additional tools or keys to set, load or adjust the power tool. Before starting the power tool always check to make certain they have been removed and are safely away from the machine.

**Prevent unintentional starting.** Before plugging any machine in to the power supply, make sure the switch is in the OFF position. If the machine is portable, do not hold the machine near the switch and take care when putting the machine down, that nothing can operate the switch.

**Carefully select an extension lead.** Some machines are not suitable for use with extension leads. If the tool is designed for use outdoors, use an extension lead also suitable for that environment. When using an extended lead, select one capable of handling the current (amps) drawn by the machine in use. Fully extend the lead regardless of the distance between the power supply and the tool. Excess current (amps) and a coiled extension lead will both cause the cable to heat up and can result in fire.

**Concentrate and stay alert.** Distractions are likely to cause an accident. Never operate a power tool if you are under the influence of drugs (prescription or otherwise), including alcohol or if you are feeling tired. Being disorientated will result in an accident.

**Have this tool repaired by a qualified person.** This tool is designed to conform to the relevant international and local standards and as such should be maintained and repaired by someone qualified, using only original parts supplied by the manufacturer. This will ensure the tool remains safe to use.

### IMPORTANT

**If using an extension lead, follow the instructions that came with your lead regarding maximum load while cable is wound. If in doubt, ensure that the entire cable is unwound. Using a coiled extension lead will generate heat which could melt the lead and cause a fire.**

## 5.2 SAFETY INSTRUCTIONS FOR RECIPROCATING SAWS

- Hold the power tool by insulated gripping surfaces, when performing an operation where the cutting accessory may contact hidden wiring or its own cord. Cutting accessory contacting a "live" wire may make exposed metal parts of the power tool "live" and could give the operator an electric shock.
- Use clamps or another practical way to secure and support the workpiece to a stable platform. Holding the workpiece by hand or against your body leaves it unstable and may lead to loss of control.

### CHANGING BLADES

- Ensure the saw is unplugged before changing blades, and take care to prevent entrapment of the fingers between the blade and the shoe. Ensure the blade is secure before use.
- Use the appropriate blade for the material being cut. Different blades are available from your Draper stockist.
- Only use blades in perfect working condition. Discard and replace any cracked or bent saw blades.

### WHEN SAWING

- Use of the mains cable. Ensure the mains cable is kept well away from the saw blade and ensure an adequate electrical supply is close at hand so that the operation is not restricted by the length of the cable.
- Allow sufficient clearance beneath the work to ensure the blade does not come into contact with the floor, bench etc.
- Switching off. Never place the saw on a table or bench if it has not completely stopped. The saw blade will continue to operate for a short time after the trigger has been released to stop the saw.

## 5. HEALTH AND SAFETY INFORMATION

---

- Cutting of pipes. Use caution when cutting hollow pipe and do not cut material where the blade can enter the pipe when fully retracted, this can cause the blade to strike the inside of the pipe causing the user to experience unexpected reaction forces.
- Cutting into walls. Do not cut through walls or cavities without checking for hidden electrical wires or water pipes etc.
- Do not attempt to remove tool from work until the blade has completely stopped and allow time for it to cool before touching the blade immediately after use.
- Use clamps and vices to secure the workpiece where possible.
- Cutting sheet materials. Do not cut material less than at least twice the pitch of the saw blade. At least two teeth must be in contact with the work at all times.
- Beware of foreign objects. When cutting pre-used wood, ensure all nails have been removed beforehand. Nails will damage the wood saw blade.
- Cooling agents. When cutting metals, always use a cooling agent i.e. cutting/soluble oil.
- Do not attempt to saw small objects including those which cannot be properly secured. Always hold the saw with both hands.

### 5.3 RESIDUAL RISK

**Important note:** Although the safety instructions and operating manuals for our tools contain extensive instructions for safe working with power tools, every power tool involves a certain residual risk which can not be completely excluded by safety mechanisms. Power tools must therefore always be operated with caution!

### 5.4 CONNECTION TO THE POWER SUPPLY

**Caution:** Risk of electric shock. Do not open.

This appliance is supplied with a moulded 3 pin mains plug for your safety. The value of the fuse fitted is marked on the pin face of the plug. Should the fuse need replacing, ensure the substitute is of the correct rating, approved to BS1362 and ASTA or BSI Kite marked.

ASTA 

BSI 

The fuse cover is removable with a small plain slot screwdriver. Ensure the fuse cover is replaced before attempting to connect the plug to an electrical outlet. If the cover is missing, a replacement must be obtained or the plug replaced with a suitable type.

If a replacement plug is to be fitted this must be carried out by a qualified electrician.

The damaged or incomplete plug, when cut from the cable should be disabled to prevent connection to a live electrical outlet.

This appliance is Class II<sup>†</sup> and is designed for connection to a power supply matching that detailed on the rating label and compatible with the plug fitted.

If an extension lead is required, use an approved and compatible lead rated for this appliance. Follow all the instructions supplied with the extension lead.

<sup>†</sup>*Double insulated* : This product requires no earth connection as supplementary insulation is applied to the basic insulation to protect against electric shock in the event of failure of the basic insulation.

### IMPORTANT

**If using an extension lead, follow the instructions that came with your lead regarding maximum load while cable is wound. If in doubt, ensure that the entire cable is unwound. Using a coiled extension lead will generate heat which could melt the lead and cause a fire.**



## 6. TECHNICAL DESCRIPTION

### 6.1 IDENTIFICATION



- ① Front hand grip.
- ② Adjustable foot.
- ③ Quick release clamp.
- ④ Rotating rear handle.
- ⑤ Handle rotation switch.

- ⑥ Trigger switch.
- ⑦ Lock-on button.
- ⑧ Rear hand grip.
- ⑨ Approved moulded plug and cable.

# 7. UNPACKING AND CHECKING

## 7.1 PACKAGING

Carefully remove the product from the packaging and examine it for any sign of damage that may have happened during shipping. Lay the contents out and check them against the parts shown below. If any part is damaged or missing, please contact the Draper Help Line (the telephone number appears on the Title page) and do not attempt to use the product.

The packaging material should be retained at least during the guarantee period: in case the machine needs to be returned for repair.

### Warning!

- Some of the packaging materials used may be harmful to children. Do not leave any of these materials in the reach of children.
- If any of the packaging is to be thrown away, make sure they are disposed of correctly, according to local regulations.

## 7.2 WHAT'S IN THE BOX

As well as the main product, there are also several other parts not fitted or attached to it:

- ⑩ Wood cutting blade (course).
- ⑪ Metal cutting blade (fine).
- ⑫ 4mm Hex. key.



## 8. PREPARING THE RECIPROCATING SAW

Remove the plug from the socket before carrying out adjustment, servicing or maintenance.

### 8.1 BLADE INSTALLATION - FIGS. 1 - 2

Turn the quick release clamp (3) counter-clockwise. Insert the blade into the slot (3.1) of quick release clamp (3).

Release the blade clamp to lock the blade.

**Warning:** When changing a blade immediately after operation, allow the blade to cool before removing to avoid possible injury.

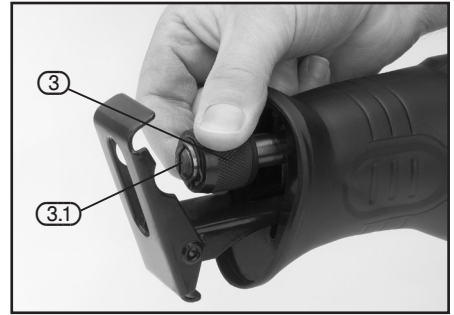

FIG.1

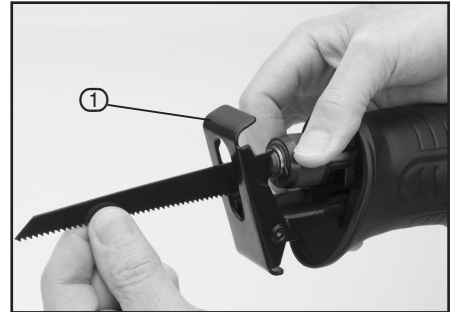

FIG.2

### 8.2 ADJUSTABLE FOOT - FIGS 3 - 4

The adjustable foot (2) adjusts backwards and forwards to allow the entire length of the blade to be used. It adjusts for special applications requiring a low clearance.

**WARNING:** To avoid injury and damage, do not operate the saw without the adjustable foot (2). The spindle may strike against the workpiece and damage the reciprocating mechanism.

Adjust the adjustable foot (2) with the 4mm hex. key (12) as necessary to make sure the blade will extend beyond the shoe and the workpiece at all times.

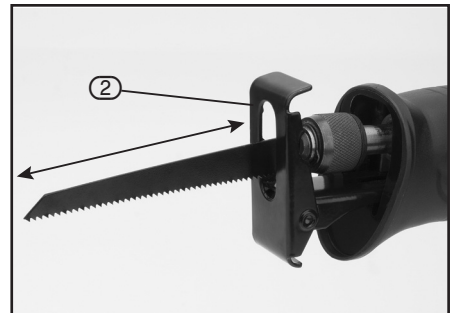

FIG.3



FIG.4

## 9. BASIC RECIPROCATING SAW OPERATION

### 9.1 SWITCH AND VARIABLE STROKE RATE CONTROL - FIG. 5

Your reciprocating saw is equipped with a trigger switch to turn the saw on and off, and to control the speed.

- To start the saw, press the trigger switch (6).
- To stop the saw, release the trigger switch.
- To vary the stroke rate, simply increase or decrease the pressure on the trigger switch. The tighter the trigger switch is pressed, the higher the speed.
- When sawing for any extended period of time it is possible to lock-on this saw. With the trigger switch (6) pressed, push in the lock-on button (7) and release (7). The saw will continue to run. To stop the saw squeeze the trigger switch (6) again and release.

**Note:** Always ensure saw trigger switch (6) is off/released after each use to prevent accidental starting.

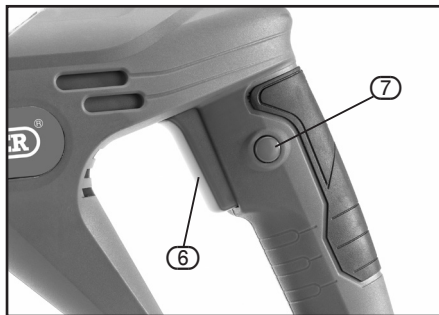

FIG.5

### 9.2 GENERAL CUTTING

**Warning:** Before plugging in the tool, always check to see that the switch is actuated properly and returns to the off position when released.

**Warning:** Hold the tool only by the rear handle and the insulated grip area, which helps prevent electrical shock. When sawing into walls or floors you may encounter electrical wiring. Sawing into a "live" wire will cause electric shock.

- Make sure the workpiece is firmly anchored. Clamp the workpiece to prevent slipping or moving while cutting.
- Use the appropriate type and size of blade for the workpiece material and size.
- Check for clearance beyond the workpiece so the blade will not impact another surface.
- Mark the line of cut clearly. If cutting metal, apply cutting oil on the line.
- Do not force the tool. Place the shoe firmly on the workpiece while cutting. Use only enough steady pressure on the blade to keep the saw cutting. Reduce pressure as the blade comes to the end of the cut.
- Cutting stroke rates should vary with the workpiece. Hard materials such as metals require lower stroke rates, for softer materials use higher stroke rates.
- Check wood, chip boards, building materials etc. for foreign objects (nails, screws, etc.) before sawing and remove them, if necessary.
- Position the pivoting footplate (2) onto the surface of the work and saw through the work applying uniform contact pressure of feed.

If the saw blade jams, switch off the tool immediately. Widen the gap somewhat with a suitable tool and pull out the saw blade.

## 9. BASIC RECIPROCATING SAW OPERATION

### 9.3 FLUSH CUTTING - FIG. 6

With the use of flexible bimetel saw blades, projecting items (i.e. water pipes, etc.) can be sawn off flush to the wall. Pay attention that the saw blade always extends beyond the diameter of the pipe being sawn. Danger of kickback.

Position the saw blade side wards against the wall and apply some lateral pressure via the tool so that the edge of the pivoting footplate 2 faces against the wall. Switch the tool on and make the cut, applying constant lateral pressure.

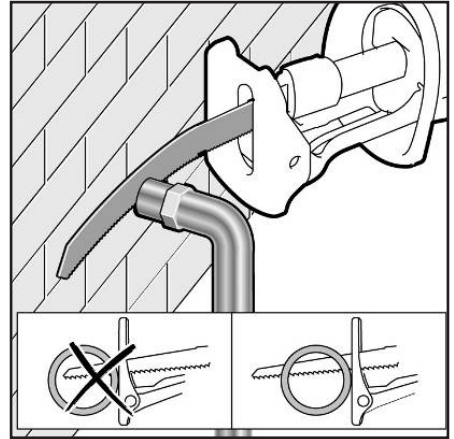

FIG.6

# 10. OPTIONAL ACCESSORIES

---

## 10.1 OPTIONAL ACCESSORIES

A full range of accessories are available from Draper Tools.

Please visit our website for details: [www.drapertools.com](http://www.drapertools.com)

# 11. MAINTENANCE AND TROUBLESHOOTING

---

## 11.1 MAINTENANCE

Regular inspection and cleaning reduces the necessity for maintenance operations and will keep your tool in good working condition.

The motor must be correctly ventilated during tool operation. Avoid blocking the air inlets and vacuum the ventilation slots regularly.

## 11.2 TROUBLESHOOTING

<b>Problems</b>	<b>Possible Causes</b>	<b>Remedy</b>
Motor does not start	1. Fuse	1. Replace time delay fuse or reset circuit breaker
	2. Brushes worn	2. Have brushes replaced in motor
	3. Other	3. Contact an authorised service centre

## 12. DISPOSAL

---

### 12.1 DISPOSAL

- At the end of the machine's working life, or when it can no longer be repaired, ensure that it is disposed of according to national regulations.
- Contact your local authority for details of collection schemes in your area.

In all circumstances:

- Do not dispose of power tools with domestic waste.
- Do not incinerate.
- Do not dispose of WEEE\* as unsorted municipal waste.



\* *Waste Electrical & Electronic Equipment.*



# 13. EXPLANATION OF SYMBOLS

## 13.1 EXPLANATION OF SYMBOLS



Read the instruction manual.



Wear face mask and safety glasses.



Wear ear defenders.



Do not abandon into the environment.



Keep out of the reach of children.



**Warning!**



Single value noise marking.  
*(Maximum declared A-Weighted sound power level in decibels).*



Class II construction  
*(Double insulated).*



WEEE –

Waste Electrical & Electronic Equipment.

*Do not dispose of Waste Electrical & Electronic Equipment in with domestic rubbish.*



For indoor use only.  
Do not expose to rain.



Short-circuit-proof safety isolating transformer

F



Fuse.



Polarity indication.



Rated voltage.





# CONTACTS

Draper Tools Limited, Hursley Road,  
Chandler's Ford, Eastleigh, Hampshire. SO53 1YF. U.K.

Helpline: (023) 8049 4344

Sales Desk: (023) 8049 4333

Internet: [drapertools.com](http://drapertools.com)

E-mail: [sales@drapertools.com](mailto:sales@drapertools.com)

General Enquiries: (023) 8026 6355

Service/Warranty Repair Agent:

For aftersales servicing or warranty repairs, please contact the Draper Tools Helpline for details of an agent in your local area.

## YOUR DRAPER STOCKIST

TAKC0818

©Published by Draper Tools Limited.

No part of this publication may be reproduced, stored in a retrieval system or transmitted in any form or by any means, electronic, mechanical photocopying, recording or otherwise without prior permission in writing from Draper Tools Ltd.