

EN

Original Instructions
Version 2 – October 2024



INVERTER GENERATOR

95176 & 95196



1. Preface

These are the original product instructions. This document is part of the product; retain it for the life of the product, passing it on to subsequent holders. Read this manual in full before attempting to assemble, operate or maintain this product.

This Draper Tools manual describes the purpose of the product and contains all the necessary information to ensure its correct and safe use. Following all the instructions and guidance in this manual will ensure the safety of both the product and the operator and increase the lifespan of the product.

All photographs and drawings within this manual are supplied by Draper Tools to help illustrate correct operation of the product.

Every effort has been made to ensure the information contained in this manual is accurate. However, Draper Tools reserves the right to amend this document without prior warning. Always use the latest version of the product manual.

1.1 Product Reference

User Manual for: Invertor Generator

Stock No: 95176, 95196

Part No: DGI800DI, DGI1200DI

1.2 Revisions

Version 1: March 2021

First release

Version 2: October 2024

As our manuals are continually updated, always ensure that the latest version is used.

Please visit drapertools.com/manuals for the latest version of this manual and the associated parts list, if applicable.

1.3 Understanding the Safety Content of This Manual



WARNING! – Situations or actions that may result in personal injury or death.



CAUTION! – Situations or actions that may result in damage to the product or surroundings.

Important: – Information or instructions of particular importance.

1.4 Copyright © Notice

Copyright © Draper Tools Limited.

Permission is granted to reproduce this manual for personal and educational use **ONLY**. Commercial copying, redistribution, hiring or lending is strictly prohibited.

No part of this manual may be stored in a retrieval system or transmitted in any other form or means without written permission from Draper Tools Limited.

In all cases, this copyright notice must remain intact.

| | | | |
|---|----|---|----|
| 1. Preface | 2 | 8. Maintenance and Troubleshooting | 18 |
| 1.1 Product Reference | 2 | 8.1 General Maintenance | 18 |
| 1.2 Revisions | 2 | 8.2 Draining the Fuel | 18 |
| 1.3 Understanding the Safety Content of This Manual | 2 | 8.3 Draining the Engine Oil | 18 |
| 1.4 Copyright © Notice | 2 | 8.4 Air Filter Care | 19 |
| 2. Contents | 3 | 8.5 Spark Plug Care | 19 |
| 3. Product Introduction | 4 | 8.6 Fuel Filter Care | 20 |
| 3.1 Intended Use | 4 | 8.7 Maintenance Schedule | 21 |
| 3.2 Specification | 4 | 8.8 Storing the Product | 21 |
| 4. Health and Safety Information | 5 | 8.9 Troubleshooting | 22 |
| 4.1 General Health and Safety Precautions | 5 | 9. Spares, Returns and Disposal | 24 |
| 4.2 Additional Health and Safety Instructions for Generators | 6 | 10. Associated Risks and Preventative Measures | 25 |
| 4.3 Health and Safety Information for Machines with a Petrol Engine | 7 | 10.1 Risk of Electrocutation and Fire | 25 |
| 4.4 Working With Lead-Acid and Other Vehicle Batteries | 7 | 10.2 Risk of Fire | 25 |
| 4.5 Residual Risk | 8 | 10.2 Risk of Fire continued | 26 |
| 5. Identification and Unpacking | 9 | 10.3 Risk of Injury and Property Damage When Transporting the Generator | 26 |
| 5.1 Product Overview | 9 | 10.4 Risk of Inhalation of Toxic Substances | 26 |
| 5.2 Packaging | 10 | 10.5 Risk of Unsafe Operation | 27 |
| 6. Preparing the Generator | 11 | 10.6 Risk of Hot Surfaces | 27 |
| 6.1 Fuelling the Generator | 11 | 10.7 Risk of Injury from Moving Parts | 27 |
| 6.2 Using E10 Petrol | 12 | 10.8 Risk of Injury During Lifting | 27 |
| 6.3 Checking and Topping Up the Engine Oil | 12 | 11. Warranty | 28 |
| 6.4 Grounding the Generator | 13 | 12. Explanation of Symbols | 29 |
| 7. Operating Instructions | 14 | | |
| 7.1 Starting the Generator | 14 | | |
| 7.2 The Economy Switch | 15 | | |
| 7.3 Stopping the Generator | 15 | | |
| 7.4 Connecting AC Appliances to the Generator | 15 | | |
| 7.5 Using the DC Outlet | 16 | | |
| 7.6 DC Circuit Breaker | 17 | | |
| 7.7 Status Indicators and AC Overload Cut-Out | 17 | | |

3. Product Introduction

3.1 Intended Use

This product is designed for use as a power generator with an output of 230V and including a DC outlet. The product is powered by a four-stroke petrol engine. Any other application beyond the conditions established for use will be considered misuse. Draper Tools accepts no responsibility for improper use of this product.

Part of our core range, this product is suitable for regular use by enthusiasts and tradespersons alike.

Read this manual in full before attempting to operate or maintain the product and retain it for later use.

3.2 Specification

| | | |
|-----------------------------------|----------------------------|----------------------------|
| Stock No. | 95176 | 95196 |
| Part No. | DGI800DI | DGI1200DI |
| AC output: | | |
| Rated output | 700W | 1,000W |
| Peak output | 800W | 1,100W |
| Rated voltage | 230V | 230V |
| Rated frequency | 50Hz | 50Hz |
| Rated current | 16A | 16A |
| DC output | | |
| Rated output | 4.0A | 4.0A |
| Rated voltage | 12V | 12V |
| Engine | | |
| Type | Four-stroke overhead valve | Four-stroke overhead valve |
| Displacement | 40cc | 60cc |
| Fuel | | |
| Type | E10* (95 RON) Unleaded | E10* (95 RON) Unleaded |
| Capacity | 2.1L | 3.0L |
| Engine oil | | |
| Type | SAE 10W-30 | SAE 10W-30 |
| Capacity | 0.25L | 0.27L |
| Cooling system | Forced air | Forced air |
| Continuous running time | 4.1 hours at 100% load | 4.4 hours at 100% load |
| Suitable batteries (for charging) | Wet lead acid | Wet lead acid |
| Noise emissions | | |
| Sound pressure level (LpA) | 67.75dB(A) | 71.63dB(A) |
| Sound power level (LWA) | 93dB(A) | 93dB(A) |
| Dimensions | W 230 x H 380 x D 425mm | W 255 x H 425 x D 480mm |
| Net weight | 9kg | 12.1kg |

*Draper Tools recommends using an additive or stabiliser with E10 petrol so the fuel can be safely stored in the fuel tank for longer.

Important: Read all the Health and Safety instructions before attempting to operate, maintain or repair this product. Failure to follow these instructions may result in injury or damage to the user or product.

4.1 General Health and Safety Precautions

Training and Inspection

- Only personnel who have read and understood this manual in full and are familiar with the operation, safe working techniques and safety features of this machine may operate, adjust or maintain this product.
 - **DO NOT** allow anyone who is unfamiliar with this product or unqualified in its use to operate this machine.
 - This machine is not intended for use by children or persons with reduced physical, sensory or mental capabilities or lack of experience and knowledge unless they have been given supervision or instruction in its use by a person responsible for their safety.
- Observe all standard safety precautions and good practices when working with petrol engines.
- Before every use, inspect the product and all accessories for broken, cracked, loose or corroded parts and leakages.

Important: **DO NOT** use this product if it is leaking or damaged in any way. Contact Draper Tools to discuss repair and replacement options.
- **DO NOT** allow familiarity or experience with this product to allow you to become complacent; remain alert at all times and **ALWAYS** adhere to the safety instructions listed in this manual.

Preparation and Intended Use

- Ensure that the surface onto which the machine is installed is flat, level, stable and capable of permanently supporting the weight of the machine.
- Ensure that the product is fully assembled, tightened and firmly fixed in place before use.
- **DO NOT** modify this product in any way and **ONLY** use spare parts supplied by Draper Tools.
- Use this product only in the manner described in this manual.
- **NEVER** stand, sit or ride on this product.

- **DO NOT** leave the machine running unattended under any circumstances; **ALWAYS** switch the machine off and allow it to cool before walking away.
- **DO NOT** exceed the maximum working capacities of this machine.
- **DO NOT** cover or obstruct any ventilation points or grilles.



CAUTION! This product is not weatherproof and **MUST NOT** be exposed to direct sunlight, high ambient temperatures, rain, frost or damp, wet and high-humidity environments.

Work Area Safety

- Keep your work environment clear and well-lit, with bystanders at a safe distance.
- Work only in daylight or in good artificial light.
- **DO NOT** use this product near open flames or sources of heat or ignition, or in any environment where explosive substances are present.
- **NEVER** operate the engine indoors or in any confined space where dangerous carbon monoxide fumes can collect; carbon monoxide is dangerous and can cause serious injury or death in a matter of minutes.

Personal Safety

- Wear suitable personal protective equipment, including ear defenders and protective gloves.
- Keep clear of heated and moving parts at all times.
- Ensure that the generator is switched off and has completely cooled before fuelling, maintaining or making any adjustment to the product.
- **DO NOT** operate this machine if you are tired or under the influence of alcohol, drugs or other medication.

Electrical Safety



WARNING!
Risk of electric shock.

- This product produces enough electrical power to cause a serious shock or electrocution if it is misused.
- **NEVER** handle or operate this machine with wet hands.
- **NEVER** expose this machine to wet conditions or frost.

4. Health and Safety Information

Maintenance

- Maintain the machine appropriately and correctly to prevent damage to moving parts and mechanisms.
- Have the machine serviced **ONLY** by authorised and suitably qualified personnel.
- Remove all adjustment tools before use.
- **ALWAYS** switch off the product and allow it to completely stop and cool before attempting to refuel or perform any adjustment, maintenance or other inspection.
- Never store the equipment with petrol in the tank inside a building where fumes can reach an open flame or spark.
- Allow the engine to cool before storing it in any enclosure.
- To reduce the risk of fire, keep the engine, muffler and petrol storage area free of vegetative material and excessive grease.
- Replace worn or damaged parts for safety.
- If the fuel tank has to be drained, it must be done outdoors.

4.2 Additional Health and Safety Instructions for Generators

Important: Electrical regulations vary between regions. This product **MUST** be used in accordance with the electrical regulations applicable to the region in which it is used.



WARNING! This product is heavy. DO NOT attempt to carry it on your own.

- The engine speed has been set at the factory to ensure safe operation.
 - **DO NOT** adjust the engine speed.
- The generator **MUST** be grounded during use.
 - Connect an earth wire to the earth terminal on the generator and press the other end of the wire into the ground or attach it to an earth spike.
- Where circuit breakers are used, they must be matched to the output of the generator.
 - Incorrect circuit breakers will not provide sufficient protection against electric shock.
- **DO NOT** connect external devices to the generator until it has been switched on and allowed to run for a few minutes.

- **DO NOT** switch on external devices until **AFTER** they have been connected to the generator.
 - When using extension lines or mobile distribution networks:
 - The resistance value must not exceed 1.5Ω.
 - The total length of lines with a cross-section of 1.5mm² must not exceed 60m.
 - The total length of lines with a cross-section of 2.5mm² must not exceed 100m.
 - **DO NOT** connect this product to a building electrical system unless an isolation switch has been installed by a qualified electrician.
 - **ALWAYS** consult a qualified electrician before connecting this product to a building or using it in highly conductive environments.
 - **NEVER** connect generators of different models and types together.
 - Ensure all appropriate safety precautions are observed when transporting the machine:
 - **ALWAYS** ensure that the machine is switched off and the spark plug cover is disconnected during transportation.
 - Drain all fuel and oil from the machine before transporting it and ensure that all reservoir caps are tightly sealed.
- Important:** If transporting it in a vehicle, keep the transportation unit well-ventilated.
- When transporting the product by hand, maintain a firm grip on the frame and keep the machine level.
 - When transporting the product in a vehicle, ensure it is kept level and strapped securely in place.
 - Keep the generator upright at all times.
 - Keep the generator out of direct sunlight during transportation.
 - Remove the generator from the vehicle immediately upon arrival at your destination.



CAUTION! All loads MUST be unplugged from the generator before the generator is started or stopped to prevent damage to connected appliances.

4.3 Health and Safety Information for Machines with a Petrol Engine



WARNING! During use, parts of this product become hot enough to ignite some materials.

DO NOT touch the engine or exhaust during or immediately after use and allow it to cool before refuelling.

- **NEVER** remove the fuel cap while the engine is running or immediately after use.
 - Take care when opening the fuel cap after use as hot vapour may be released from the opening.
- **NEVER** place objects on the engine while it is in use and keep all air vents clear of dust, dirt and other obstructions.
- Faulty mufflers must be replaced.
- **NEVER** store the machine with fuel in the tank inside any structure where petrol fumes could reach an open flame or spark.
- To reduce the risk of fire, keep the engine, exhaust and petrol storage area free from vegetation and excessive grease.



WARNING!
Petrol is highly flammable:

- Store fuel in containers specifically designed for this purpose.
- **NEVER** use this machine in environments where there is a risk of explosion.
- **NEVER** smoke in the vicinity of the machine.
- Refuel outdoors only and do not smoke while refuelling.
- Add fuel before starting the engine; never remove the cap of the fuel tank or add petrol while the engine is running or when the engine is hot.
- **NEVER** start the engine if you can smell petrol vapour in the air.
- If petrol is spilled, do not attempt to start the engine but move the machine away from the area of spillage and avoid creating any source of ignition until petrol vapours have dissipated.
- Replace all fuel tank and container caps securely.

Important: E10 petrol is hygroscopic and attracts moisture. Read all the preparation and maintenance information relating to E10 fuel before using it in this machine. Draper Tools recommends using an additive or

stabiliser with E10 petrol to extend the period that it can be safely stored in the fuel tank. **ALWAYS** read the label of any additive or stabiliser applied.



WARNING! The machine exhaust emits toxic carbon monoxide: a colourless, odourless gas.

Breathing exhaust fumes can cause loss of consciousness, permanent respiratory damage and eventually death. **ONLY** operate this machine in a well-ventilated outdoor environment, well away from windows and doors. If you inhale carbon monoxide, move to a ventilated area and seek immediate medical attention.

4.4 Working With Lead-Acid and Other Vehicle Batteries



WARNING!
Risk of explosive gases.

- Working in close proximity to lead-acid batteries is dangerous as they produce potentially explosive gases during normal operation.
- **ALWAYS** read this manual in full and keep your work area thoroughly ventilated. Contact Draper Tools for assistance if you are not confident in the use of this product.
- Use this manual in conjunction with the battery manufacturer's manual and that of any other equipment to be used in the vicinity. Review all safety markings and rating plates present on the battery, charger and any other nearby equipment before using this product to charge a vehicle battery.
- **DO NOT** work with vehicle batteries on your own; **ALWAYS** ensure that someone is nearby to come to your aid if necessary.
- Wear complete eye and hand protection and wear suitable clothing that covers your skin appropriately.
 - Avoid touching your eyes while working with lead-acid batteries.
- Keep plenty of fresh water and soap nearby in case battery acid comes into contact with your skin, eyes or clothing.
 - If battery acid comes into contact with your skin or clothing, wash the affected area immediately with soap and water.
 - If battery acid enters your eyes, flush the eye immediately with copious cool and clean running water for at least 15 minutes and seek medical attention immediately.

4. Health and Safety Information

- **NEVER** smoke or allow sparks or flames in the vicinity of the battery or engine.
- Take extra care to prevent metal objects or tools from falling onto the battery as this may cause a spark, short-circuit the battery or cause an explosion.
- **ALWAYS** remove personal metallic objects before use.
 - Lead-acid batteries can produce a short-circuit current high enough to weld metal and cause severe burns.



WARNING! DO NOT top up the electrolyte beyond the manufacturer's recommended level. Overfilling the battery may cause the acid content to leak.

4.5 Residual Risk

The safety instructions in this manual cannot account for all possible conditions and situations that may occur. Exercise common sense and caution when using this product and protect against any additional conceivable risks.

5.1 Product Overview



- | | |
|---------------------------------|--|
| (1) Air vent knob | (12) Fuel tap |
| (2) Fuel tank cap | (13) Recoil starter |
| (3) Engine power switch | (14) Side maintenance covers |
| (4) Economy mode control switch | (15) Priming bulb |
| (5) Output indicator | (16) Choke lever |
| (6) Overload warning indicator | (17) Exhaust |
| (7) Oil alert indicator | (18) Top maintenance cover |
| (8) 230V 16A AC outlet | (19) Transport handle |
| (9) 12V DC outlet | (20) Spark plug spanner |
| (10) DC circuit breaker | (21) Cross head screwdriver |
| (11) Earth terminal | (22) 12V DC battery charging lead (pair) |

5. Identification and Unpacking

5.2 Packaging

Keep the product packaging for the duration of the warranty period in case the product needs to be returned for repair.

WARNING! Keep packaging materials out of reach of children. Dispose of packaging correctly and responsibly and in accordance with local regulations.

Please visit [drapertools.com](https://www.drapertools.com) for our full range of accessories and consumables.

6. Preparing the Generator

Important: Before using this product, read and understand all the safety instructions listed in this manual.

6.1 Fuelling the Generator

CAUTION! This machine is shipped **WITHOUT fuel**. Check the fuel level before **EVERY** use and top up as appropriate. **NEVER** attempt to run the engine on an empty fuel tank.

Important: This product must be used with high-quality unleaded fuel **ONLY**. **ALWAYS** use automotive petrol suitable for four-stroke engines; **DO NOT** mix fuel and oil. Draper Tools recommends E10 (95 RON) automotive fuel, with an appropriate additive or stabiliser, for use with this product. Damage caused by failure to add fuel or by the use of incorrect or poor-quality fuel is not covered by your warranty.

CAUTION! E10 petrol is hygroscopic and attracts moisture, which may damage the fuel system if stored in the product for more than four weeks. See 6.2 Using E10 Petrol.

WARNING! **ALWAYS** fuel the machine in a well-ventilated area away from sources of ignition. Store fuel only for short periods, away from direct sunlight and heat sources, and only in containers specifically designed for that purpose. Avoid prolonged contact with the skin and inhalation of petrol vapour.

To fuel the machine:

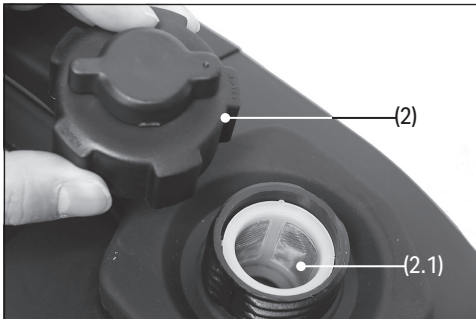

Fig. 1

1. Disconnect the spark plug cover; see 8.5 Spark Plug Care.
2. Remove the fuel tank cap (2).

WARNING! If the machine has been recently used, hot steam may vent from the fuel tank outlet. Take care when opening the fuel tank.

3. Ensure that the fuel filter (2.1) is in place. **Important:** **DO NOT** add fuel to the tank if the fuel filter is missing or damaged.



Fig. 2

4. Carefully pour fuel into the tank until the level reaches the red marker inside the filter.

CAUTION!

- **DO NOT** overfill the fuel tank; always leave an air gap above the fuel level.
- **NEVER** allow dust, dirt, water or dirty fuel to enter the fuel tank. Clean up any spillages **IMMEDIATELY**.

5. Reattach the fuel tank cap, ensuring it is properly fitted and securely tightened.
6. Reconnect the spark plug cover when the machine is ready for use.

Important: Move the generator at least 4m (12') away from the fuelling area before starting the engine.

6. Preparing the Generator

6.2 Using E10 Petrol

E10 petrol is hygroscopic: this means that it attracts and mixes with water from the air, which accumulates in the engine and the petrol deteriorates more quickly. If E10 petrol is stored in a machine's fuel tank for extended periods, this build-up of water can form a corrosive gum that rusts the fuel system from the inside.

The use of petrol additives or stabilisers are recommended when using E10 petrol. Additives and stabilisers are widely available and can extend the length of time that E10 petrol can be safely stored in a product fuel tank.

The impact of additives or stabilisers on the lifespan of the fuel varies with each product and will deteriorate over time – always read the label. E10 petrol should not remain in the fuel tank for more than four weeks without an additive or stabiliser.

Even where additives or stabilisers are used, it is recommended that E10 fuel is drained from the fuel tank every three to four weeks to reduce the risk of damage to the product. The fuel must be drained from the fuel tank within the time limit specified by any additives or stabilisers added to the fuel. If the machine will not be used for longer than this time, drain it before putting it into storage.

After draining the fuel tank, always run the engine until the last of the fuel in the system is spent and drain the float bowl when the engine is cool.

E10 petrol should be used within 30 days of purchase.

Some petrol brands contain other quantities of ethanol. **DO NOT** use fuels with more than 10% ethanol.

Always store and dispose of fuels responsibly and in accordance with local regulations.

6.3 Checking and Topping Up the Engine Oil



CAUTION! This machine is **NOT** supplied with engine oil.

- **Check the engine oil level before every use.**
- **Running the machine with a low oil level oil may cause serious damage to the engine and is not covered by your warranty.**
- **Important:** Use SAE 10W-30 oil with this machine.

1. Ensure that the generator is switched off and has completely cooled, then place it on a stable and level surface.



Fig. 3

2. Unscrew and remove the left side maintenance cover (14 & 14.1).

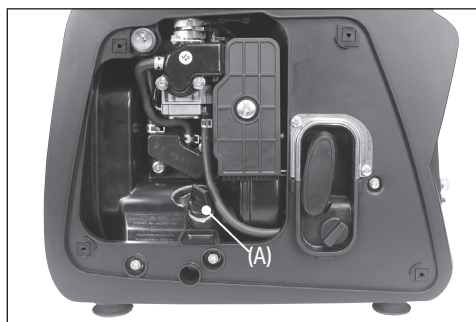

Fig. 4

3. Rotate the oil filler cap (A) anticlockwise to remove it from the reservoir and clean it.
4. Insert the oil filler cap back into the reservoir and remove it again.
Important: DO NOT screw the filler cap into place when checking the oil level; insert the cap into the reservoir and remove it again.

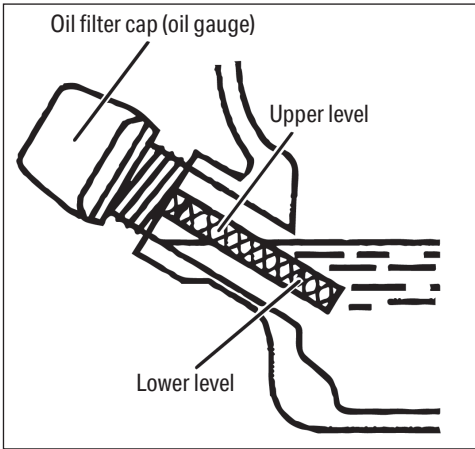

Fig. 5

5. Inspect the oil level on the oil filler cap against the MIN and MAX level markings:

CAUTION! DO NOT overfill the oil as this may cause the oil to overflow into the air filter.

- If the oil is below the MIN level marking, top up with oil until the MAX marking is reached.
- If the oil has become contaminated or discoloured, drain and replace the oil; see **8.3 Draining the Engine Oil**.

Important: The motor on this engine is fitted with a low oil sensor. If the oil level drops too low, the engine will stop and cannot be started until the oil level is topped up. Attempting to start the engine with low oil levels may still cause significant damage to the engine components due to insufficient lubrication.

WARNING! Prolonged exposure to used oil can be harmful to your health. Wash your hands thoroughly after handling engine oil.

6.4 Grounding the Generator

WARNING! Risk of electric shock. The generator **MUST** be grounded before use.

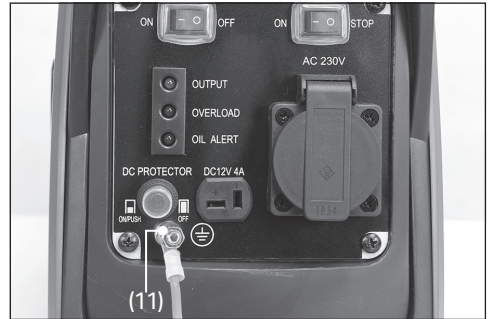

Fig. 6

To ground the generator, tighten the earth terminal nut against a grounding wire and press the other end of the wire into the ground or attach it to an earth spike.

DO NOT use this product without connecting it to earth.

7. Operating Instructions

Important: Before operating this product, read and understand all the safety instructions listed in this manual. Ensure that the generator is correctly prepared before use; see **6. Preparing the Generator**.

Important: The first 25 hours of use are considered the break-in period for this engine. During this time, **DO NOT** operate the engine at less than 75% of the load limit.

Important: Generators vibrate during operation. Periodically inspect the power plugs of connected appliances for vibration damage during and after use with the generator. If the generator vibrates excessively while operating, switch it off, allow it to cool and investigate the cause before continuing.

7.1 Starting the Generator

CAUTION!

- This machine is **NOT** shipped with fuel or oil. **DO NOT** attempt to start the engine until both the fuel tank and engine oil have been checked and topped up accordingly.
- **CAUTION! NEVER** start the generator if it is already connected to a load.

Important: **DO NOT** start the generator until it is in its operating position. **NEVER** travel with the machine switched on.

WARNING! NEVER operate this product indoors or in enclosed spaces.

1. Ensure that the oil and fuel tanks are suitably filled and that the generator is correctly grounded.
2. Hold the fuel tank cap to prevent it from moving and turn the air vent knob (1) to the open position.

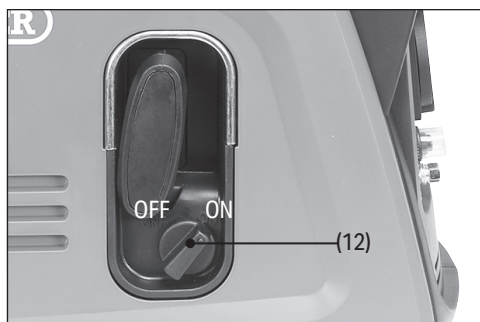

Fig. 7

3. Ensure that the spark plug cover is connected and turn the fuel tap (12) to the ON position.

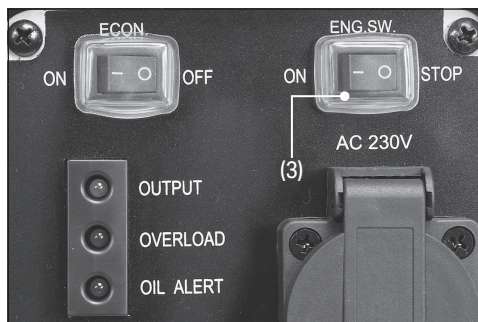

Fig. 8

4. Move the engine power switch (3) to the 'ON' (-) position.

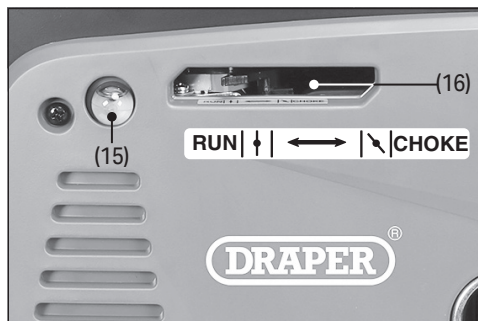

Fig. 9

5. Move the choke lever (16) to the appropriate position:
 - **Cold start:** Closed 'Choke' position
 - **Warm start:** Open 'RUN' position
6. If necessary, prime the engine by pressing the priming bulb (15) at least six times.

CAUTION!

- **ONLY** press the priming bulb if the generator has not been recently used or the fuel had run out.
- Check the fuel lines to the carburettor: if they do not contain fuel, the engine must be primed.
- **DO NOT** over-prime the generator as this will flood the spark plug and the engine will not start.

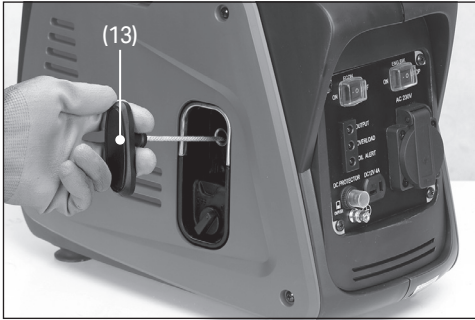

Fig. 10

7. Slowly pull on the recoil starter (13) until resistance is felt, then pull it out rapidly to start the engine.

Important: You may need to do this several times.

⚠ CAUTION!

- **DO NOT** attempt to start the engine when the recoil starter is fully retracted.
 - **DO NOT** allow the recoil starter to snap back against the engine. Return it gently to prevent damage to the starter.
8. If you are performing a cold start:
- Allow the engine to run with no load for a few minutes to allow it to warm up.
 - Move the choke lever to the 'RUN' position.

7.2 The Economy Switch

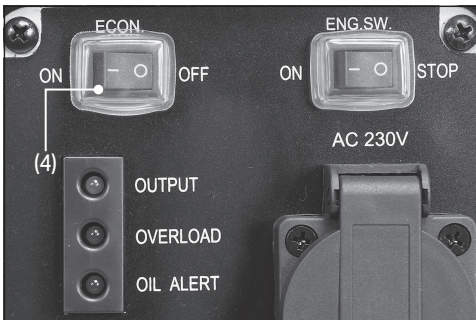

Fig. 11

This product is fitted with an economy switch. To enable economy mode, move the switch (4) to the 'ON' (-) position.

It is recommended to keep the economy mode 'ON' during most operations. When economy mode is active, the generator will consume less fuel and operate with reduced noise levels when no load is drawn. The engine speed varies according to the load.

Important:

- Economy mode does not work effectively if the connected appliances draw 'bursts' of power.
- **ALWAYS** disable the economy mode while high-load appliances are connected.
- **ALWAYS** disable the economy mode when using the DC outlet (9).
- After starting the generator, allow the engine to settle for a few minutes before connecting external appliances and enabling economy mode.

7.3 Stopping the Generator

Important: Except in emergency situations, **ALWAYS** switch off and disconnect all connected appliances before switching off the generator. Failure to do so may damage the appliances.

1. Switch off and unplug any connected appliances from the generator.
2. Allow the engine to idle for a few minutes.
3. Move the engine power switch (3) to the 'STOP' (O) position.
4. Turn the fuel tap (12) to the 'OFF' position.

Important: **IMMEDIATELY** switch off the generator if any of the following occur:

- Excessive engine noise, e.g., knocking or rattling.
- The circuit breakers behave abnormally.
- Smoke or a strong odour is emitted from anywhere other than the generator exhaust.

Important: **ALWAYS** ensure that the engine power switch is in the 'STOP' (O) position while the generator is not in use.

7.4 Connecting AC Appliances to the Generator

⚠ CAUTION!

- **DO NOT** connect a load until the generator engine is running and has warmed up.
- **Connected appliances MUST NOT** be switched on until after they have been connected to the generator.

Important: **ALWAYS** check the rating plate of external appliances **BEFORE** connecting them to the generator. This generator has a fixed rated power output. The combined load from all connected appliances must **NOT** exceed this value.

7. Operating Instructions

1. Start the generator engine, ensure that economy mode is disabled and allow it to run with no load for a few minutes; see **7.1 Starting the Generator**.
2. Ensure that the external appliance is switched off and then plug into the appropriate outlet.
 - **Important:** After each external appliance is connected, allow a few minutes for the generator to stabilise before connecting the next appliance.
3. Enable economy mode once the required appliances are connected.

Notes on Connecting Appliances

- If the 230V AC and 12V DC outlets are in use at the same time, the DC circuit breaker (10) may trip.
- This generator can withstand short voltage spikes of up to its peak output value.
 - Important:** Motorised products require additional energy upon start-up. Some products rated at below the peak output value may fail to start if their starting current significantly exceeds it.
- As the AC output is pure sine wave, this product is safe for use with sensitive appliances such as laptops.
- Switch off connected appliances before disconnecting them from the generator or switching the generator off.
- If an appliance exhibits unusual behaviour, switch off the generator immediately and examine the appliance for signs of malfunction.

7.5 Using the DC Outlet

The 12V DC outlet (9) can be used to top up wet lead-acid batteries **ONLY**.

Important: These instructions are intended as a guide **ONLY**. **ALWAYS** refer to the vehicle and battery manufacturer's manuals for specific instructions relating to the vehicle to be charged as the procedure varies between batteries. Any manufacturer instructions relating to other equipment to be used in the immediate area should also be consulted. Read all instructions in full **BEFORE** charging a lead-acid battery using this product.

Important: Draper Tools recommends that no other appliances are plugged into this product while it is being used to charge a lead-acid battery.

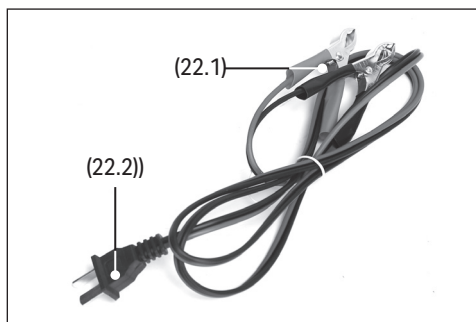

Fig. 12

1. If the vehicle battery is not a maintenance-free or sealed battery:
 - Remove the cell filler caps and check the level of electrolyte.
 - If necessary, top up the electrolyte to the manufacturer's recommended level using distilled or deionised water.
 - ⚠ **CAUTION!** Top up with distilled or deionised water **ONLY**. **NEVER** top up lead-acid batteries with tap water.
 - ⚠ **WARNING!** Battery fluid is corrosive. **DO NOT** touch the battery fluid or overfill the cells.
 - Check the electrolyte density (specific gravity) using a hydrometer (not supplied) to ensure that the acid to water ratio is sufficient.
2. Clean the battery terminals with a dry cloth to optimise conduction with the terminal clamps.
 - Important:** **ALWAYS** wear protective gloves when handling battery terminals.
3. Measure the battery voltage for indications of deep discharge using a multimeter (not supplied) or a similar tool.
 - Important:** Deep discharging the battery to 20% or less of its full charge capacity can cause significant damage to batteries. **DO NOT** attempt to charge a deep-discharged battery using this product.
4. Refer to the vehicle and battery manufacturer instructions for guidance on connecting the 12V DC lead clamps (22.1) to the battery terminals and charging.
 - Most vehicles require the **positive** (red) clamp to be connected before the negative (black) clamp; **ALWAYS** follow the manufacturer instructions.

WARNING! If the terminals are connected using the incorrect polarity, disconnect them IMMEDIATELY to avoid damaging the battery.

5. Insert the charging lead plug (22.2) into the generator's 12V DC outlet (9) to begin charging.
6. Monitor the voltage across the battery regularly during charging and disconnect the battery when the voltage reaches 12.4V.
Important: In most cases, the negative (black) cable should be disconnected from the battery first, then the positive (red) cable.

7.6 DC Circuit Breaker

The DC outlet is equipped with a circuit breaker that is activated when the load current becomes too high. When tripped, the circuit breaker cuts power to the DC outlets.



Fig. 13

The DC circuit breaker (10) pops out from the unit when tripped. It can be reset by allowing the generator to rest for a few minutes and then pressing the circuit breaker back into the unit.

Note: A likely cause of the safety switch activation is substantial overloading or poor condition of the external appliances.

If the circuit breaker is tripped:

1. Switch off and disconnect all connected appliances then switch off the generator.
2. Reset the circuit breaker in the usual way.
3. Restart the generator.
4. Gradually reintroduce the external appliances, ensuring that the load is at a lower level than the point when the switches were tripped.

If the circuit breaker does not reset after disconnecting the appliances and restarting the generator, contact Draper Tools for support. **DO NOT** continue to use the generator until the issue is rectified.

7.7 Status Indicators and AC Overload Cut-Out

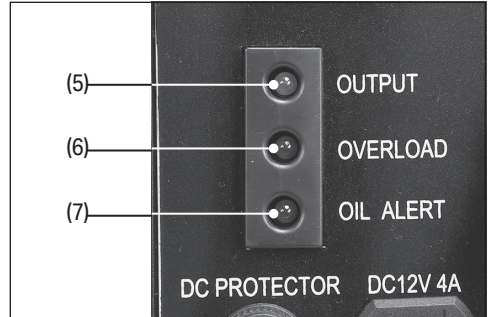

Fig. 14

The product interface features three status indicators:

- **Output (green) (5):**
The product is operating normally.
- **Overload (red) (6):**
The load on the AC outlets is too great.
- **Oil alert (yellow) (7):**
The oil level is low and the engine cannot run; top up the oil immediately (see 6.3).

If the **overload** indicator is illuminated, power to the AC sockets is cut off. When this occurs, switch off and disconnect any external appliances and move the engine power switch (3) to the '**STOP**' (0) position. When the generator has cooled, check the air inlet around the interface and engine and clear any obstructions. Allow the product to rest for a few minutes, then switch it back on.

Examine the appliances for signs of damage or malfunction before reconnecting them to the generator. Ensure that the connected load is lower than it was when the overload occurred.

If the AC cutout does not reset after restarting the product correctly, contact Draper Tools for support.

8. Maintenance and Troubleshooting

Important: Maintenance and repairs should be carried out **ONLY** by authorised and suitably qualified personnel.

 **WARNING! ALWAYS turn off the engine and allow it to cool before maintaining or storing this product. If the engine must be run for testing, ensure that this is carried out in a well-ventilated environment that allows carbon monoxide from the exhaust to dissipate quickly.**

For optimal performance and a longer lifespan, maintain the generator according to the schedule outlined in this section. If the generator is used in abnormally hot or dusty environments, increase the frequency of each aspect of the maintenance schedule.

8.1 General Maintenance

- **ALWAYS** keep all air vents clean and free from obstructions.
- Clean the machine with a damp cloth **ONLY**. **Important: DO NOT** use solvents as this may damage any plastic or uninsulated parts.
- Use **ONLY** spare parts supplied by Draper Tools.

8.2 Draining the Fuel

Important: Fuel should be stored in the tank for no more than four weeks. Draper Tools recommends draining the fuel from the generator before storage, particularly if the machine will be stored for long periods.

Important: Read all the Health and Safety guidance for the use of petrol as a fuel before filling or draining this product.

 **WARNING! NEVER drain the fuel tank indoors.**

To drain the fuel:

1. Turn the fuel tap (12) to the '**OFF**' position.
2. Use a siphon (not supplied) to extract the fuel into a suitable container.
3. Identify the fuel line leaving the tap and detach it. **Important:** The fuel line may leak when detached. Catch any discharged fuel in a suitable container.
4. Position a funnel (not supplied) to direct the fuel into a suitable container.
5. Open the fuel tap and allow the remaining fuel to drain from the fuel tank.
6. When the fuel is drained, close the fuel tap.

7. Loosen the float bowl drain bolt and allow the fuel to drain into a suitable container.
8. Move the fuel tap (12) to the '**ON**' position and allow the fuel to drain from the tank.
9. When the fuel has drained, tighten the float bowl drain bolt and wipe up any spillages.
10. Start the engine and allow it to run until it exhausts the residual fuel in the system.

Important: **ALWAYS** dispose of waste fuel responsibly and in accordance with local regulations.

8.3 Draining the Engine Oil

Important: The engine oil level and condition should be inspected before every use and replaced every three months or after 50 hours of use. It should additionally be replaced after the first month or 20 hours of use, and if it becomes contaminated with water or debris.

Drain the oil before the engine has completely cooled to allow faster and more thorough drainage.

 **WARNING! ALWAYS wear protective gloves when draining the oil as the oil and reservoir will be hot.**

1. Position the generator on level ground and start the engine normally.
2. Allow a few minutes for the engine to warm up, then switch off the generator.
3. Remove the oil filler cap.

 **WARNING! Be mindful of hot vapours escaping from the oil reservoir when the filler cap is removed.**

4. Loosen the oil drain bolt and allow the oil to drain into a suitable container.
5. Check the gaskets and clean or replace them as required.
6. Refit the drain bolt, then refill the oil and check the level (see **6.3 Checking and Topping Up the Engine Oil**).
7. Tighten the oil filler cap securely in place and reposition the generator on level ground.

Important: **ALWAYS** dispose of waste oil responsibly and in accordance with local regulations.

WARNING! Prolonged exposure to used oil can be harmful to your health. Wash your hands thoroughly after handling engine oil.

8.4 Air Filter Care

Clean the air filter chamber and element at least after every 50 hours of use or every three months to ensure consistent airflow into the carburettor. Increase the frequency of cleaning when working in dusty environments.

WARNING! NEVER use petrol or solvents to clean the air filter elements as they may damage the filter or result in a fire when the machine is next used.

CAUTION! NEVER run the machine without the air filter elements in place as this may cause the engine to degrade rapidly.

1. Ensure that the choke lever (16) is in the closed 'Choke' position to prevent any debris from entering the carburettor.



Fig. 15

2. Unscrew and remove the left side maintenance panel (14 & 14.1).

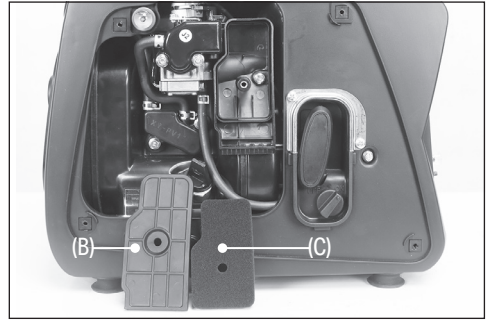

Fig. 16

3. Unscrew and remove the air filter (B) cover.
4. Extract the foam filter element (C) and inspect it for holes, tears and obstructions. **Important:** If the foam element is damaged, replace it with a new one. **DO NOT** use the machine if the air filter is damaged.
5. Wash the element in warm soapy water and allow it to dry thoroughly. **Important: DO NOT** use solvents to clean the element.
6. Clean the compartment and covers of any dust, dirt or other obstructions.
7. Reassemble the air filter and fix the cover securely in place, ensuring it is correctly seated in the housing.
8. Reattach the side maintenance cover.

8.5 Spark Plug Care

Ensure that the spark plug is clean and correctly gapped. The spark plug may become contaminated over time if the machine is run with part-throttle for prolonged periods.

Important: Replace the spark plug after every 50 hours of use or every three months.

8. Maintenance and Troubleshooting

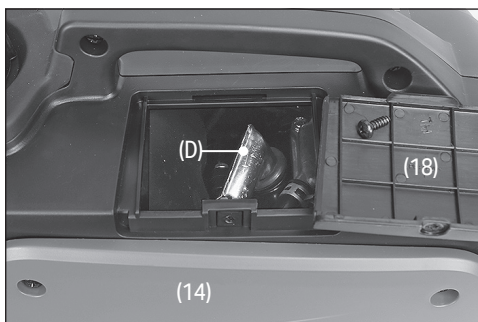

Fig. 17

1. Unscrew and remove the top maintenance cover (18).
2. Remove the spark plug cover (D).
Important: DO NOT use tools to remove the cover as it may damage the HT lead.
3. Pass the shaft of the screwdriver through the holes across the spark plug spanner body and use the assembled spanner to remove the spark plug.
4. Visually inspect the spark plug and replace it if the ceramic insulator is cracked or chipped.
5. Measure the spark plug gap using a feeler gauge (not supplied) and correct as appropriate by gently bending the electrode into position.
Important: The gap should be **0.6–0.7mm**.
6. Screw the spark plug into place using 20Nm (2mkg, 14ftlb) of torque and replace the spark plug cover securely.

CAUTION!

- **The spark plug MUST be correctly tightened. Loose spark plugs can become very hot and cause damage to the engine.**
- **NEVER use a spark plug with a heat range that is not appropriate for the machine in which it is used.**

8.6 Fuel Filter Care

The fuel filter (2.1) sits inside the fuel tank opening and ensures that the fuel remains clean. It must be checked regularly and replaced when it becomes clogged.

Important: Wear protective gloves to protect your hands from the fuel.

1. Disconnect the spark plug cover (D).
2. Drain the fuel from the tank; see **8.2 Draining the Fuel**.
3. Remove the fuel tank cap (2) and extract the fuel filter.
4. Inspect the filter for damage and clean or replace it as necessary:
 - Thoroughly clean the filter using warm soapy water and allow it to dry completely.
Important: DO NOT use solvents to clean the element.
 - Replace the filter if it is damaged or clogged.
5. Insert the fuel filter back into the opening and replace the fuel tank cap securely.

8.7 Maintenance Schedule

| REGULAR SERVICE PERIOD | | Before each use | First month or 20hrs | Every 3 months or 50hrs | Every 6 months or 100hrs | Every 2 years or 300hrs |
|------------------------|--------------|-----------------|---|-------------------------|--------------------------|-------------------------|
| Engine oil | Check level | • | | | | |
| | Change | | • | • | | |
| Air cleaner | Check | • | | | | |
| | Clean | | | • [†] | | |
| Spark plug | Check adjust | | | • | | |
| | Replace | | | | • | |
| Spark arrester | Clean | | | | • | |
| Valve clearance | Check adjust | | | | | • [‡] |
| Combustion camber | Clean | | | After every 300 hrs | | |
| Fuel tank and filter | Clean | | | • [‡] | | |
| Fuel line | Check | | Every two years (replace if necessary) [‡] | | | |

For guidance relating to any of the listed procedures, contact the Draper Helpline; details can be found on the back page of this manual.

[†]Clean the air filter more frequently if the product is used in particularly dusty environments.

[‡]These items should be performed by an authorised service dealer unless you are technically proficient and own the proper equipment required.

8.8 Storing the Product

Important: ALWAYS ensure that the engine has completely cooled before storing the machine.

- Prepare the machine correctly for storage:
 - Ensure that the engine power switch is in the 'STOP' (O) position.
 - Disconnect the spark plug cover (D).
 - Drain the fuel from the tank and carburettor.
 - Tighten all reservoir caps and leakage points.
 - Cover the machine with a plastic sheet to protect it against dust and moisture.
- Store the machine and attachments in a dry and dust-free environment, out of reach of children.

- Store the machine at a temperature of 0–30°C.
- Start the engine at periodic intervals and allow it to run for several minutes to prevent seizure within the engine.

If the machine is to be stored for a prolonged period, ensure that the engine cylinder is sufficiently lubricated to prevent it from seizing:

1. Remove the spark plug; see **8.5 Spark Plug Care**.
2. Pour a few drops of SAE 10W-30 oil into the socket.
3. Pull the recoil starter (13) slowly to distribute the oil.
4. Return the spark plug securely to the socket.

8. Maintenance and Troubleshooting

5. When restarting after storage:
 - a. Remove the spark plug.
 - b. Hold a cloth around the spark plug socket opening.
Important: DO NOT smother or completely cover the opening.
 - c. Pull on the recoil starter several times and catch any ejected oil using the cloth.
Do this until no more oil is ejected from the opening.
 - d. Return the spark plug securely to the socket
 - e. Start the engine in the usual way; see **7.1 Starting the Generator**.

8.9 Troubleshooting

| Problem | Possible Cause | Remedy |
|--|---|--|
| The engine will not start. | The engine power switch is in the 'STOP' (O) position. | Press the engine power switch to the 'ON' (I) position. |
| | The fuel or oil level is too low. | Check and top up the fuel and oil levels as appropriate (see 6.2 and 6.3). |
| | The fuel tap is closed. | Rotate the fuel tap to the open position. |
| | The spark plug electrode has been fouled or the gap is set incorrectly. | Repair or replace the spark plug. |
| | The spark plug H.T. lead is not connected correctly. | Press the spark plug cover on firmly and ensure that the housing is not interfering with the connection. |
| | The choke is set incorrectly for the starting conditions. | Ensure that the choke lever is set in the open position for a warm start or closed for a cold start. |
| | The air filter is clogged. | Clean or replace the air filter (see 8.4). |
| | The fuel filter is clogged. | Replace the fuel filter (see 8.6). |
| A load has been applied before starting the generator. | Disconnect the external appliance and retry. | |
| The engine stutters or runs roughly after starting. | The choke lever is set in the closed position. | Move the choke lever to the open position and retry. |
| | Parts of the engine require maintenance. | Clean or replace the air filter, fuel filter and spark plug (see 8.4 and 8.5). |
| | The fuel has been stored for too long and has deteriorated. | Drain the fuel (see 8.3) and clean the fuel filter (see 8.6), then refuel the generator (see 6.1). |

| Problem | Possible Cause | Remedy |
|--|---|---|
| The engine stops automatically during operation. | The fuel level has dropped too low. | Check and top up the fuel tank (see 6.1). |
| | The load exceeds the rated capacity of the generator. | Check the rating plates of all connected appliances and reduce the load on the generator as appropriate. |
| The engine runs with low power. | Parts of the engine require maintenance. | Clean or replace the air filter, fuel filter and spark plug. |
| | The choke is closed. | Open the choke after the engine has run for a few seconds. |
| The generator is leaking oil. | An O-ring seal is damaged or failing. | Replace the faulty part; contact Draper Tools for support. |
| | There are loose bolts in the engine. | Tighten all bolts and fittings. |
| There is no electrical output. | The circuit breaker or overload cut-out has been activated. | For DC cut-outs, disconnect the appliances and press the circuit breaker. For AC devices, switch off and disconnect the devices, then switch off the generator. Retry after a few minutes. |
| | The receptacle is faulty. | Contact Draper Tools for support. |
| | The motor brushes are worn. | Contact Draper Tools for support. |
| The circuit breakers trip repeatedly. | The generator is overloaded. | Reduce the load and retry. |
| | The connected appliances are faulty or poorly connected. | Inspect the appliances for damage and check the connection to the generator outlets. |
| The generator overheats. | The generator is overloaded. | Reduce the load and retry. |
| | The generator is not sufficiently ventilated. | Move the generator to a location with increased ventilation. |

9. Spares, Returns and Disposal

For spare parts, servicing, and repair and replacement options, please contact the Draper Tools Product Helpline for details of your nearest authorised agent.

Draper Tools will endeavour to hold any spare parts, if applicable, for seven years from the date that it sells the final matching stock item.

Any servicing or repairs carried out by unauthorised personnel or installation of spare parts not supplied by Draper Tools will invalidate your warranty.

Important: For safety, **ALWAYS** drain and clean the product of any oil, fuel, chemicals or other substances before returning it to Draper Tools or its authorised agent. Store these materials in suitable containers and dispose of them in accordance with local regulations. Draper Tools and its agents cannot be responsible for the disposal of these substances.

At the end of its working life, dispose of the product responsibly and in line with local regulations. Recycle where possible.

- **DO NOT** dispose of this product with domestic waste; most local authorities provide appropriate recycling facilities.
- Dispose of oil and fuel separately and in accordance with local regulations; **DO NOT** abandon them in the environment.



10.1 Risk of Electrocutation and Fire

| Hazard | What could happen | How to prevent it |
|---|---|--|
| Improper positioning of the power cords of connected appliances. | Power cords can come into contact with hot parts of the engine and be damaged. Passing current through a damaged power cord can result in electrocution or death. | Reposition power cords so that they do not pass within close proximity to the engine and heated parts of the generator. |
| Operation of the generator in rain or wet, icy or flooded environments. | Water that comes into contact with electrically charged components can transmit electricity to the frame and other surfaces, resulting in electrocution. | Operate the product in a clean, dry and well-ventilated area. Ensure your hands are dry before touching the unit. |
| Placement of the generator on or against highly conductive surfaces, such as a steel walkway or a metal roof. | Accidental leakage of electrical current could charge conductive surfaces in contact with the generator. | Place the generator on a low-conductivity surface, such as a concrete slab. Always operate the generator at a minimum of 2m from any conductive surface. |
| Operation of the generator when it is damaged or when guards or panels have been removed. | Attempting to use the unit when it has been damaged or when it is not functioning normally could result in fire or electrocution. Removal of guards or panelling could expose electrically charged components and result in electrocution. | Do not operate the generator if it exhibits mechanical or electrical problems. Have the product repaired by an authorised service agent. Do not operate the generator if any of the protective guarding has been removed. |

10.2 Risk of Fire

| Hazard | What could happen | How to prevent it |
|---|---|---|
| Attempting to fill the fuel tank while the engine is running. | Fuel and fuel vapours can become ignited if they come into contact with hot components such as the muffler, exhaust gases or an electrical spark. | Turn the engine off and allow it to cool completely before adding fuel to the tank. Ensure that a fire extinguisher suitable for petrol fires is located within the working area. |
| Sparks, fire and hot objects. | Cigarettes, sparks, fires and other hot objects can cause fuel or fuel vapours to ignite. | Add fuel to the tank in a well-ventilated area. Always ensure that sources of heat and ignition are kept well away from the generator. |
| Improper storage of fuel. | Fuel stored improperly may result in accidental ignition or may be accessible to children and unauthorised personnel. | Store fuel in an approved container designed to hold fuel, and in a secure location away from flammable materials and sources of heat and ignition. |

10. Associated Risks and Preventative Measures

10.2 Risk of Fire continued

| Hazard | What could happen | How to prevent it |
|---|--|---|
| Tampering with the factory-set engine speed settings. | The engine speed has been set at the factory to provide safe operation of the machine. Tampering with the engine speed adjustment could result in the attachments overheating and cause a fire. | Never attempt to speed up the engine to improve performance. This will impact both the output voltage and output frequency and endanger any connected appliances, as well as the user. |
| Inadequate ventilation of the generator. | Materials placed on, against or near to the generator, or operation of the generator in areas where the ambient temperature exceeds 40°C, may interfere with the proper ventilation of the machine and cause overheating, which may result in the ignition of those materials. | Operate the generator in a clean, dry and well-ventilated area. Do not operate the generator indoors or in any confined area. Never cover or place objects onto the generator. |
| Overfilling of the fuel tank. | Spilled fuel and its vapours can become ignited by hot surfaces or sparks. | Exercise extreme caution when filling the fuel tank to avoid spillages. Ensure that the fuel tank cap is securely tightened and check the engine for fuel leaks before switching on the machine. Allow for fuel expansion. Never refuel with the engine running. |

10.3 Risk of Injury and Property Damage When Transporting the Generator

| Hazard | What could happen | How to prevent it |
|--|---|---|
| Fire, inhalation and damage to vehicle surfaces. | Fuel and oil can leak or spill and may result in a fire or breathing hazard and cause serious injury or death. Fuel and oil leaks can damage carpet, paint and other surfaces in vehicles and trailers. | Ensure that the fuel tap is set to the closed position before transporting the generator to avoid fuel leaks. Transport fuel only in a suitable container designed for that purpose. Always place the generator on a protective mat when transporting to protect vehicles from damage caused by leaks. Remove the generator from the vehicle immediately upon arrival at the destination. |

10.4 Risk of Inhalation of Toxic Substances

| Hazard | What could happen | How to prevent it |
|---|--|---|
| Petrol engines produce toxic carbon monoxide exhaust fumes. | Breathing exhaust fumes may cause serious injury or death. | Operate the generator in a clean, dry and well-ventilated area. Never operate the machine in enclosed areas such as garages, basements and sheds, or in any location inhabited by humans or animals. Keep children, pets and unauthorised personnel away from the machine at all times. |

10.5 Risk of Unsafe Operation

| Hazard | What could happen | How to prevent it |
|---|--|---|
| Operation of the generator in a careless manner. | All sources of energy carry the potential for injury. Unsafe operation or maintenance of the generator may lead to serious injury or death to you or others. | <p>Review and understand all of the safety and operation instructions in this manual.</p> <p>Become familiar with the operation and controls of this machine, particularly how to switch it off quickly.</p> <p>Ensure that a fire extinguisher suitable for petrol fires is located within the working area.</p> <p>Keep children, pets and unauthorised personnel away from the machine at all times.</p> |
| Operation of the generator in a suspended or uneven position. | The generator will not operate properly and may become damaged if it is not orientated correctly and may cause serious injury if it is not stable or secure. | Never operate the generator in a suspended or uneven position. Always place it on a flat, level and stable surface. |

10.6 Risk of Hot Surfaces

| Hazard | What could happen | How to prevent it |
|--|--|---|
| Contact with hot parts of the engine and other components. | Contact with hot surfaces, such as the engine exhaust components, may result in serious burns. | During operation, handle only the dedicated control and gripping surfaces of the generator. Keep children, pets and unauthorised personnel away from the generator at all times as they may be unable to identify the hazardous areas of the product. |

10.7 Risk of Injury from Moving Parts

| Hazard | What could happen | How to prevent it |
|---|---|--|
| Contact with moving parts may result in serious injury. | The generator contains parts which rotate at high speed during operation. | These parts are covered by guarding to prevent injury. Never operate the generator without this complete guarding in place. Avoid wearing loose-fitting clothing and jewellery that could become caught in moving parts. |

10.8 Risk of Injury During Lifting

| Hazard | What could happen | How to prevent it |
|------------------------------|--|--|
| The generator is very heavy. | Attempting to lift an item unsafely or that is too heavy for your capability may result in serious injury. | <p>When lifting, always keep the object near the vertical axis of your body. Do not use your back to lift heavy loads. This product should be carried by two people.</p> <p>Both people should crouch down, bending at the knees, and grip the underside of the unit. Using your legs to bear the weight, keep the item as close to your body's centre of gravity as possible. Avoid twisting your body when carrying the unit and instead turn your whole body using your feet.</p> |

11. Warranty

Draper Tools products are carefully tested and inspected before shipment and are guaranteed to be free from defective materials and workmanship.

Should the tool develop a fault, return the complete tool to your nearest distributor or contact Draper Tools directly. Contact information can be found at the back of this manual.

Proof of purchase must be provided.

If, upon inspection, it is found that the fault occurring is due to defective materials or workmanship, repairs will be carried out free of charge. This warranty period covers parts and labour for 12 months from the date of purchase. Where tools have been hired out, the warranty period covers 90 days from the date of purchase.

This warranty does not apply to any consumable parts, batteries or normal wear and tear, nor does it cover any damage caused by misuse, careless or unsafe handling, alterations, accidents, or repairs attempted or made by any personnel other than the authorised Draper Tools repair agent.

In all cases, to make a claim for faulty workmanship or materials within the standard warranty period, please contact or return the product to the place of purchase. Proof of purchase may be required.

If the place of purchase is no longer trading or if you experience any difficulties with your warranty, please contact Customer Services with the product details and your proof of purchase. Contact details can be found at the back of this manual.

If the tool is not covered by the terms of this warranty, repairs and carriage charges will be quoted and charged accordingly.

This warranty supersedes any other guarantees expressed or implied and variations of its terms are not authorised.

Your Draper Tools guarantee is not effective until you can produce, upon request, a dated receipt or invoice to verify your purchase within the guarantee period.

Please note that this warranty is an additional benefit and does not affect your statutory rights.

Draper Tools Limited

12. Explanation of Symbols



Read the instruction manual



Warning!



Warning! – Hot surfaces, risk of burns



Danger! Risk of electrocution



Maintain a safe distance from the product during use



Earthed/Product must be grounded while switched on



Top up oil level before every use



Never use this product indoors



Not weatherproof



Outdoors use only



The generator must not be connected to the public power supply



Warning! – Emits toxic exhaust fumes



WEEE –

Waste Electrical & Electronic Equipment

Do not dispose of Waste Electrical & Electronic Equipment in with domestic rubbish



Do not abandon in the environment



European conformity



UK Conformity Assessed

Contact Details

Draper Tools

Draper Tools Limited
Hursley Road
Chandler's Ford
Eastleigh
Hampshire
SO53 1YF
UK

Website: drapertools.com

Email: sales@drapertools.com

Product Helpline: +44 (0) 23 8049 4344

Telephone Sales Desk: +44 (0) 23 8049 4333

General Enquiries: +44 (0) 23 8026 6355

Delta International

Delta International BV
Oude Graaf 8
6002 NL
Weert
Netherlands

Please contact the Draper Tools Product Helpline for repair and servicing enquiries.