



DRAPER[®]

230V QUIET GARDEN SHREDDER

97974



These instructions accompanying the product are the original instructions. This document is part of the product, keep it for the life of the product passing it on to any subsequent holder of the product. Read all these instructions before assembling, operating or maintaining this product.

This manual has been compiled by Draper Tools describing the purpose for which the product has been designed, and contains all the necessary information to ensure its correct and safe use. By following all the general safety instructions contained in this manual, it will ensure both product and operator safety, together with longer life of the product itself.

All photographs and drawings in this manual are supplied by Draper Tools to help illustrate the operation of the product.

Whilst every effort has been made to ensure the accuracy of information contained in this manual, the Draper Tools policy of continuous improvement determines the right to make modifications without prior warning.

1. TITLE PAGE

1.1 INTRODUCTION:

USER MANUAL FOR: 230V Quiet Garden Shredder

Stock No: 97974

Part No: GSS2800D

1.2 REVISIONS:

Date first published February 2021.

As our user manuals are continually updated, users should make sure that they use the very latest version.

Downloads are available from: <http://drapertools.com/manuals>

Draper Tools Limited
Hursley Road
Chandler's Ford
Eastleigh
Hampshire
SO53 1YF
UK

Website: drapertools.com

Product Help Line: +44 (0) 23 8049 4344

General Fax: +44 (0) 23 8026 0784

1.3 UNDERSTANDING THIS MANUALS SAFETY CONTENT:

Warning! – Information that draws attention to the risk of injury or death.

Important – Information that draws attention to the risk of damage to the product or surroundings.

1.4 COPYRIGHT © NOTICE:

Copyright © Draper Tools Limited.

Permission is granted to reproduce this publication for personal and educational use only.

Commercial copying, redistribution, hiring or lending is prohibited.

No part of this publication may be stored in a retrieval system or transmitted in any other form or means without written permission from Draper Tools Limited.

In all cases this copyright notice must remain intact.

2. CONTENTS

2.1 CONTENTS

1. TITLE PAGE	
1.1 INTRODUCTION	2
1.2 REVISION HISTORY	2
1.3 UNDERSTANDING THIS MANUAL'S SAFETY CONTENT	2
1.4 COPYRIGHT © NOTICE	2
2. CONTENTS	
2.1 CONTENTS	3
3. WARRANTY	
3.1 WARRANTY	4
4. INTRODUCTION	
4.1 SCOPE	5
4.2 SPECIFICATION	5
4.3 HANDLING AND STORAGE	5
5. HEALTH AND SAFETY INFORMATION	
5.1 GENERAL POWER TOOL SAFETY WARNINGS	6-7
5.2 RESIDUAL RISK	7
6. TECHNICAL DESCRIPTION	
6.1 IDENTIFICATION	8
7. UNPACKING AND CHECKING	
7.1 PACKAGING	9
7.2 WHAT'S IN THE BOX	9
8. PREPARING THE SHREDDER	
8.1 ASSEMBLY	10
8.2 PREPARATION	10
9. OPERATING THE SHREDDER	
9.1 START UP OPERATION	11
9.2 OVERLOAD PROTECTION	11
9.3 USING THE PLUNGER	11
9.4 KEEPING THE SHREDDER CLEAN	12
9.5 ADJUSTING THE COUNTERPLATE	12
9.6 REPLACING THE COUNTERPLATE	12
10. MAINTENANCE & TROUBLESHOOTING	
10.1 MAINTENANCE	13
10.2 TROUBLESHOOTING GUIDE	13
11. EXPLANATION OF SYMBOLS	
11.1 EXPLANATION OF SYMBOLS	14
12. DISPOSAL	
12.1 DISPOSAL	15

3. WARRANTY

3.1 WARRANTY

Draper tools have been carefully tested and inspected before shipment and are guaranteed to be free from defective materials and workmanship.

Should the tool develop a fault, please return the complete tool to your nearest distributor or contact:

Draper Tools Limited, Chandler's Ford, Eastleigh, Hampshire, SO53 1YF. England.

Telephone Sales Desk: +44 (0) 8049 4333 or Product Help Line +44 (0) 23 8049 4344.

A proof of purchase **must** be provided with the tool.

If upon inspection it is found that the fault occurring is due to defective materials or workmanship, repairs will be carried out free of charge. This warranty period covering labour and parts is 12 months from the date of purchase except where tools are hired out when the warranty period is 90 days from the date of purchase. This warranty does not apply to any consumable parts, any type of battery or normal wear and tear, nor does it cover any damage caused by misuse, careless or unsafe handling, alterations, accidents, or repairs attempted or made by any personnel other than the authorised Draper warranty repair agent.

Note: If the tool is found not to be within the terms of warranty, repairs and carriage charges will be quoted and made accordingly.

This warranty applies in lieu of any other warranty expressed or implied and variations of its terms are not authorised.

Your Draper warranty is not effective unless you can produce upon request a dated receipt or invoice to verify your proof of purchase within the warranty period.

Please note that this warranty is an additional benefit and does not affect your statutory rights.

Draper Tools Limited.

4. INTRODUCTION

4.1 SCOPE

Part of our core range, this product is suitable for enthusiasts and tradespersons alike for the shredding of garden waste, for foliage with a maximum capacity of 44mm. Any other application is considered misuse.

4.2 SPECIFICATION

Stock No.	97974
Part No.	GSS2800D
Motor:	
Rated voltage	230V~
Rated frequency	50Hz
Rated input	2800W
Speed (no load)	60rpm
Max. cutting diameter	44mm
Sound pressure level (LpA)	79.1dB(A)
Sound power level (LWA)	94dB(A)
Uncertainty (K)	3dB(A)
Weight (machine only)	20.5kg

4.3 HANDLING AND STORAGE

- Care must be taken when handling this product.
 - Dropping this power tool could have an effect on its accuracy and could also result in personal injury. This product is not a toy and must be respected.
- Environmental conditions can have a detrimental effect on this product if neglected.
 - Exposure to damp air can gradually corrode components. If the product is unprotected from dust and debris, components will become clogged.
 - If not cleaned and maintained correctly or regularly, the machine will not perform at its best.

5. HEALTH AND SAFETY INFORMATION

5.1 GENERAL SAFETY INSTRUCTIONS FOR POWER TOOL USE

When using any type of power tool there are steps that should be taken to make sure that you, as the user, remain safe.

Common sense and a respect for the tool will help reduce the risk of injury.

Read the instruction manual fully. Do not attempt any operation until you have read and understood this manual.

Most important you must know how to safely start and stop this machine, especially in an emergency.

Keep the work area tidy and clean. Attempting to clear clutter from around the machine during use will reduce your concentration. Mess on the floor creates a trip hazard. Any liquid spilt on the floor could result in you slipping.

Find a suitable location. If the machine is bench mounted, the location should provide good natural light or artificial lighting as a replacement. Avoid damp and dust locations as it will have a negative effect on the machine's performance. If the machine is portable do not expose the tool to rain. In all cases do not operate power tools near any flammable materials.

Keep bystanders away. Children, onlookers and passers by must be restricted from entering the work area for their own protection. The barrier must extend a suitable distance from the tool user.

Unplug and house all power tools that are not in use. A power tool should never be left unattended while connected to the power supply. They must be housed in a suitable location, away locked up and from children. This includes battery chargers.

Do not overload or misuse the tool. All tools are designed for a purpose and are limited to what they are capable of doing. Do not attempt to use a power tool (or adapt it in any way) for an application it is not designed for. Select a tool appropriate for the size of the job. Overloading a tool will result in tool failure and user injury. This covers the use of accessories.

Dress properly. Loose clothing, long hair and jewellery are all dangerous because they can become entangled in moving machinery. This can also result in parts of body being pulled into the machine. Clothing should be close fitted, with any long hair tied back and jewellery and neck ties removed. Footwear must be fully enclosed and have a non-slip sole.

Wear personal protective equipment (PPE). Dust, noise, vibration and swarf can all be dangerous if not suitably protected against. If the work involving the power tool creates dust or fumes wear a dust mask. Vibration to the hand, caused by operating some tools for longer periods must be protected against. Wear vibration reducing gloves and allow long breaks between uses. Protect against dust and swarf by wearing approved safety goggles or a face shield. These are some of the more common hazards and preventions, however, always find out what hazards are associated with the machine/work process and wear the most suitable protective equipment available.

Do not breathe contaminated air. If the work creates dust or fumes connect the machine (if possible) to an extraction system either locally or remotely. Working outdoors can also help if possible.

Move the machine as instructed. If the machine is hand held, do not carry it by the power supply cable. If the product is heavy, employ a second or third person to help move it safely or use a mechanical device. Always refer to the instructions for the correct method.

Do not overreach. Extending your body too far can result in a loss of balance and you falling. This could be from a height or onto a machine and will result in injury.

Maintain your tools correctly. A well maintained tool will do the job safely. Replace any damaged or missing parts immediately with original parts from the manufacturer. As applicable, keep blades sharp, moving parts clean, oiled or greased, handles clean, and emergency devices working.

5. HEALTH AND SAFETY INFORMATION

Wait for the machine to stop. Unless the machine is fitted with a safety brake, some parts may continue to move due to momentum. Wait for all parts to stop, then unplug it from the power supply before making any adjustments, carrying out maintenance operations or just finishing using the tool.

Remove and check setting tools. Some machinery requires the use of additional tools or keys to set, load or adjust the power tool. Before starting the power tool always check to make certain they have been removed and are safely away from the machine.

Prevent unintentional starting. Before plugging any machine in to the power supply, make sure the switch is in the OFF position. If the machine is portable, do not hold the machine near the switch and take care when putting the machine down, that nothing can operate the switch.

Carefully select an extension lead. Some machines are not suitable for use with extension leads. If the tool is designed for use outdoors, use an extension lead also suitable for that environment. When using an extended lead, select one capable of handling the current (amps) drawn by the machine in use. Fully extend the lead regardless of the distance between the power supply and the tool. Excess current (amps) and a coiled extension lead will both cause the cable to heat up and can result in fire.

Concentrate and stay alert. Distractions are likely to cause an accident. Never operate a power tool if you are under the influence of drugs (prescription or otherwise), including alcohol or if you are feeling tired. Being disorientated will result in an accident.

Have this tool repaired by a qualified person. This tool is designed to conform to the relevant international and local standards and as such should be maintained and repaired by someone qualified, using only original parts supplied by the manufacturer. This will ensure the tool remains safe to use.

5.2 RESIDUAL RISK

Important: Although the safety instructions and operating manuals for our tools contain extensive instructions of safe working with power tools, every power tool involves a certain residual risk which can not be completely excluded by safety mechanisms. Power tools must therefore always be operated with caution!

6. TECHNICAL DESCRIPTION

6.1 IDENTIFICATION

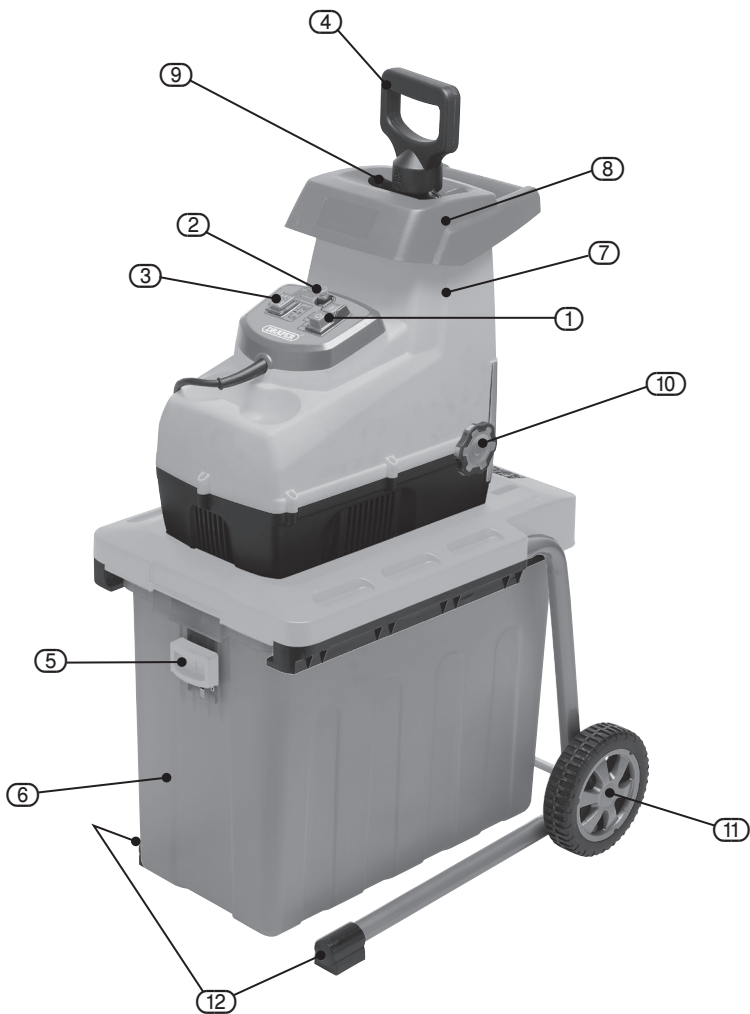

① On/off switch.

② Circuit breaker button.

③ Forward/reverse switch.

④ Plunger.

⑤ Collection box catch.

⑥ Collection box.

⑦ Top feed housing.

⑧ Hopper.

⑨ Feed chute

⑩ Counterplate adjusting knob.

⑪ Wheel and cover.

⑫ Support feet.

7. UNPACKING AND CHECKING

7.1 PACKAGING

Carefully remove the product from the packaging and examine it for any sign of damage that may have happened during shipping. Lay the contents out and check them against the parts shown below. If any part is damaged or missing, please contact the Draper Help Line (the telephone number appears on the Title page) and do not attempt to use the product.

The packaging material should be retained at least during the warranty period, in case the machine needs to be returned for repair.

Warning!

- Some of the packaging materials used may be harmful to children. Do not leave any of these materials in the reach of children.
- If any of the packaging is to be thrown away, make sure they are disposed of correctly, according to local regulations.

7.2 WHAT'S IN THE BOX

As well as the main product, there are several parts not fitted or attached to it.



(13) Wheel axle.

(14) Hex key.

(15) Spanner.

Note: For details of our full range of accessories and consumables, please visit drapertools.com

8. PREPARING THE SHREDDER

8.1 ASSEMBLY – FIGS. 1 - 5

1. With the machine upside down turn the two feet to the appropriate location (Fig. 2).
2. Place the axle bar between the legs and mount the wheels ensuring the nut is not too tight (Figs. 3 & 4). Attached wheel cover (Fig. 5) and turn the machine the right way up. **Take care when tilting the unit onto its wheels as the unit has an uneven weight distribution.**
3. Pull down the collection box catch (5) and slide the collection box to the appropriate location and push catch upwards to secure. If catch is not closed the motor will not activate.

NOTE: It is dangerous to use the machine without the hopper (8).



FIG. 1



FIG. 2

8.2 PREPARATION

Before using the machine, read the instructions thoroughly and acquaint yourself with the features of the machine.

1. Inspect the material to be shredded before starting. Remove any objects or debris that could be thrown, jammed or become entangled in the blades. Remove any soil from root balls. Foreign bodies like stones, glass, metals, fabrics, or plastics must not enter the in-feed chute, these could damage the blades.
2. Always place the machine on firm level ground. During operation, do not tilt or move.
3. Allow the cutting blades to reach full speed before feeding the material into the in-feed chute.
4. Use the machine to shred the following materials only:
 - Twigs and branches (Max. diameter 44mm)
 - Waste from pruning bushes
 - Waste from trimming hedges
 - Plant material and other garden waste
 - Leaves and plant roots (remove soil from roots before shredding)
5. Feed the material to be shredded into the corner of the in-feed chute, if it is not too bulky, the material will be drawn in by the blades.
6. Do not over fill the in-feed chute.
7. **Warning:** Material extending out from the machine could lash out. Please keep at safe distance.
8. Ensure the shredded material can fall freely from the discharge chute.
9. To make finer compost, shred for a second time.
10. Do not allow the shredded material to build up and block the discharge chute. If it does, it could reach the cutting blades and be thrown out of the in-feed chute.
11. Organic material contains a large amount of water and sap that can stick to the shredder. To avoid this, material should be left for a few days to dry out. Large branches however are best shredded when they are fresh.
12. Switch off and unplug from the mains before investigating if:
 - The blade stalls
 - Any foreign objects are struck
 - Unusual noises/vibrations
 - The appliance becomes cloggedBefore restarting:
 - Inspect for damage
 - Replace or repair any damaged parts
 - Check for and tighten any loose partsAllow the machine to cool for at least 1 minute before restarting the machine.
13. Keep the motor cooling vents clean of debris and other accumulations to prevent damage to the motor or possible fire.
14. When not in used and under supervision, make sure the machine is off and unplugged from the mains.
15. Do not allow processed material to build up in the discharge zone; this may prevent proper discharge and can result in kickback of material through the feed intake opening.



FIG. 3



FIG. 4



FIG. 5

9. OPERATING THE SHREDDER

9.1 START UP OPERATION – FIG. 6

1. Select Forward/Reverse by pressing switch (3).
2. Press the On/Off switch (1) to ON (I) position to start the motor.
3. Press the On/Off switch (1) to OFF (O) position to stop the motor.

CAUTION:

Damage to the machine due to improper operation. Incorrect handling can result in machine damage. Only feed materials to be shredded after the machine was switched on. Do not feed materials to be shredded after the machine was switched off.

NOTE:

The machine is equipped with a safety switch to prevent it from being switch on again accidentally after a power failure.

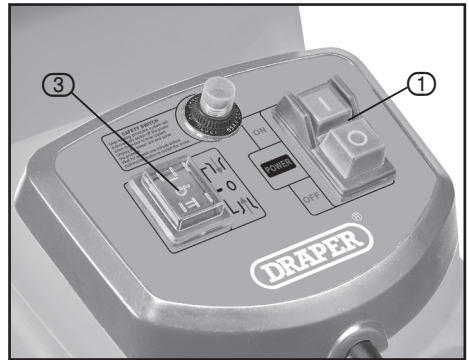

FIG. 6

9.2 OVERLOAD PROTECTION – FIG. 7

This machine is equipped with an overload protection system. To protect the motor from being damaged, the safety switch will automatically switch off the power when the motor is overloaded.

Wait at least 1 minute before restarting by first pressing the reset button and then the On/Off switch. If the motor does not restart, do the following :

1. Press the safety switch (2).
2. Press the Forward/Reverse Button (3) to REVERSE position.
3. Press and hold the On/Off switch (1) to ON (I) position to remove any objects that could obstruct the blades.

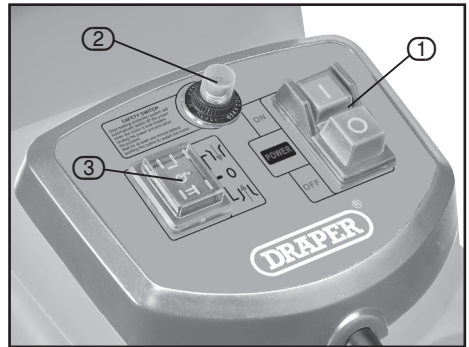

FIG. 7

ATTENTION:

Always wear safety gloves when executing the steps mentioned above.

9.3 USING THE PLUNGER – FIG. 8

There is a plunger provided to aid feeding less bulky material such as small twigs, leaves, other garden waste and vegetation into the in-feed chute.

1. Load the material into the hopper.
2. Insert the plunger (4) into the in-feed chute pushing the material onto the blade disc.
3. Wait until all the material has been shredded before adding more material.

NOTE:

Your fingers must never enter the in-feed chute. Never use the tool if the hopper is not fitted. Do not over reach.



FIG. 8

9. OPERATING THE SHREDDER

9.4 KEEPING THE SHREDDER CLEAN

Before commencing cleaning and maintenance procedures, make sure the garden shredder is switched off and disconnected from the mains supply. Always wear sturdy leather gloves when cleaning the cutter blades.

To ensure the best performance from the garden shredder, it must be kept clean.

1. Always clean the garden shredder immediately after use.
2. Do not allow material to become dry and hard on any of the garden shredder surface. This will directly affect the shredding performance.
3. Make sure that the inlet chute and the ejector chute are kept clean and clear of all waste material.
4. Make sure that all nuts, bolts and screws are tight and secure.
5. Always have any damaged or worn parts repaired, or replaced by qualified personnel.
6. Do not use detergents or solvents as these could cause irreparable damage to your machine. Chemicals can destroy the plastic parts.

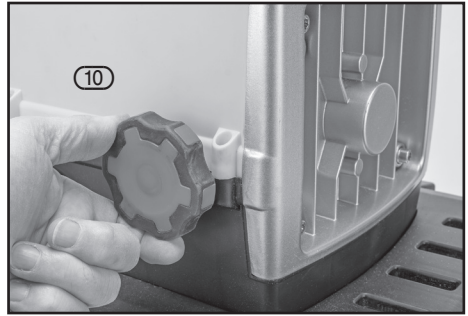

FIG. 9

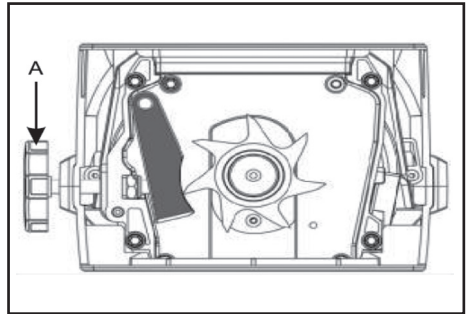

FIG. 10

9.5 ADJUSTING THE COUNTERPLATE – FIGS. 9 - 10

To obtain an optimum shredding result and prevent damage to the blade, the counterplate must be adjusted at regular intervals. The counterplate must also be adjusted so that interlinkage occurs.

1. Turn counterplate adjusting knob (A) clockwise until a slight friction noise can be heard and fine aluminum chips fall from the ejector chute for a short period of time.
2. Then the materials to be shredded should be fully cut again.

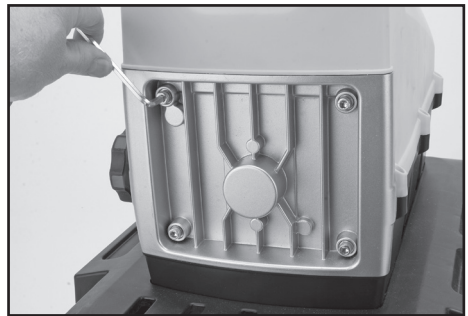

FIG. 11

9.6 REPLACING THE COUNTERPLATE – FIGS. 11 - 12

1. Open the back cover by loosening 4 screws.
2. Take out the counterplate (B) and replace with a new one.
3. Put back the back cover and use a wrench to fix the screws.

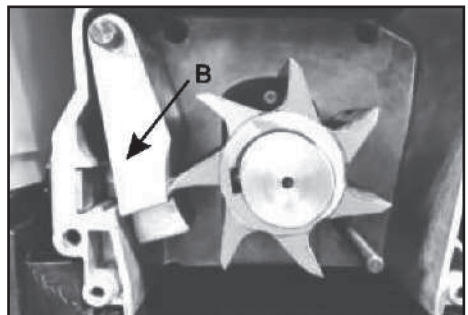

FIG. 12

10. MAINTENANCE AND TROUBLESHOOTING

10.1 MAINTENANCE

Regular inspection and cleaning reduces the necessity for maintenance operations and will keep your tool in good working condition.

1. **Warning:** During maintenance and cleaning ensure the machine is disconnected from the mains.
2. When the appliance is stopped for servicing, inspection, or storage, or to change an accessory, switch off and pull the plug from the mains supply before making any inspections, adjustments, etc.
3. If an extension cord is used it shall not be of lighter grade than the supply cord already fitted to the appliance.
4. Check the supply and any extension cord regularly for damage or signs of ageing. Do not use the appliance, if the cords are damaged.
5. When servicing the cutting means be aware that, even though the motor will not start due to the interlock feature of the guard, the cutting means can still be moved if the motor is turned by hand.
6. Never attempt to override the interlock feature of the top feed housing.
7. Remove deposited matter from the machine using a brush.
8. Always clean the machine after use. Clean the plastic body and plastic parts using soap and a moist cloth. Do not use aggressive agents or solvents for cleaning.
9. Never clean the shredder with a jet of water or by rinsing. Make sure that no water is allowed to enter into the shredder.

10.2 TROUBLESHOOTING GUIDE

Problem	Possible Cause	Remedy
Motor does not start.	1. Safety switch.	1. Check if the switch still functions well.
	2. Power failure.	2. Check the power supply cable, the plug and the house fuse.
	3. Unsure.	3. Return to an authorised service agent for diagnosis.
Poor shredding performance.	1. The material is jammed in the feeding funnel.	1. Switch the shredder OFF. Pull the material from the feed funnel. Switch the shredder back ON and re-feed thick branches such that the blade does not immediately engage the pre-cut notches again.
	2. Shredding material is too soft.	2. Insert wood or shred dried branches.
	3. Overload	Press the reset button and then the On/Off switch. If it still does not start, take the steps indicated in section 9.2 'Overload Protection' (page 11).

11. EXPLANATION OF SYMBOLS

11.1 EXPLANATION OF SYMBOLS



Read the instruction manual.



Wear safety glasses.



Wear ear defenders.



Wear protective gloves.



Warning!



Safety cut-out facility.



Danger!

Risk of flying debris.



Remove plug from power supply before carrying out any maintenance & when not in use.



Warning! Sharp objects.



Warning!

Keep bystanders away.



Pay more attention to the operator's hands and feet to avoid injury.



Do not operate the machine indoors.



Class II construction
(Double insulated).



WEEE –
Waste Electrical & Electronic Equipment.
Do not dispose of Waste Electrical & Electronic
Equipment in with domestic rubbish.



Continuous A-Weighted Sound
Pressure Level.

12. DISPOSAL

12.1 DISPOSAL

- At the end of the machine's working life, or when it can no longer be repaired, ensure that it is disposed of according to national regulations.
- Contact your local authority for details of collection schemes in your area.

In all circumstances:

- Do not dispose of power tools with domestic waste.
- Do not incinerate.
- Do not dispose of WEEE* as unsorted municipal waste.



* *Waste Electrical & Electronic Equipment.*

CONTACTS

Draper Tools Limited, Hursley Road,
Chandler's Ford, Eastleigh, Hampshire. SO53 1YF. U.K.

Help Line: (023) 8049 4344

Sales Desk: (023) 8049 4333

Internet: drapertools.com

E-mail: sales@drapertools.com

General Enquiries: (023) 8026 6355

Service/Warranty Repair Agent:

For aftersales servicing or warranty repairs, please contact the Draper Tools Help Line for details of an agent in your local area.

YOUR DRAPER STOCKIST

TAJB0221

©Published by Draper Tools Limited.

No part of this publication may be reproduced, stored in a retrieval system or transmitted in any form or by any means, electronic, mechanical photocopying, recording or otherwise without prior permission in writing from Draper Tools Ltd.