



**DRAPER**<sup>®</sup>

# PETROL INVERTER GENERATOR

98683



UK  
CA CE

These instructions accompanying the product are the original instructions. This document is part of the product, keep it for the life of the product passing it on to any subsequent holder of the product. Read all these instructions before assembling, operating or maintaining this product.

This manual has been compiled by Draper Tools describing the purpose for which the product has been designed, and contains all the necessary information to ensure its correct and safe use. By following all the general safety instructions contained in this manual, it will ensure both product and operator safety, together with longer life of the product itself.

All photographs and drawings in this manual are supplied by Draper Tools to help illustrate the operation of the product.

Whilst every effort has been made to ensure the accuracy of information contained in this manual, the Draper Tools policy of continuous improvement determines the right to make modifications without prior warning.

# 1. TITLE PAGE

---

## 1.1 INTRODUCTION:

**USER MANUAL FOR: Petrol Inverter Generator**

**Stock No: 98683**

**Part No: PG4000**

## 1.2 REVISIONS:

---

**Date first published January 2021.**

---

**Date of first revision December 2022.**

---

---

As our user manuals are continually updated, users should make sure that they use the very latest version.

**Downloads are available from:** <http://drapertools.com/manuals>

Draper Tools Limited	Draper Tools Limited
Hursley Road	Oude Graaf 8
Chandler's Ford	6002 NL
Eastleigh	WEERT
Hampshire	Netherlands
SO53 1YF	
UK	

**Website:** [drapertools.com](http://drapertools.com)

**Product Help Line:** +44 (0) 23 8049 4344

**General Fax:** +44 (0) 23 8026 0784

## 1.3 UNDERSTANDING THIS MANUALS SAFETY CONTENT:

**Warning!** – Information that draws attention to the risk of injury or death.

**Important** – Information that draws attention to the risk of damage to the product or surroundings.

## 1.4 COPYRIGHT © NOTICE:

Copyright © Draper Tools Limited.

Permission is granted to reproduce this publication for personal and educational use only.

Commercial copying, redistribution, hiring or lending is prohibited.

No part of this publication may be stored in a retrieval system or transmitted in any other form or means without written permission from Draper Tools Limited.

In all cases this copyright notice must remain intact.

## 2. CONTENTS

---

### 2.1 TABLE OF CONTENTS

<b>1. TITLE PAGE</b>			
1.1 INTRODUCTION: .....	2	9.3 ADDING ENGINE OIL .....	13
1.2 REVISIONS: .....	2	9.4 ADDING FUEL.....	14
1.3 UNDERSTANDING THIS MANUALS SAFETY CONTENT: ..	2	<b>10. OPERATING INSTRUCTIONS</b>	
1.4 COPYRIGHT © NOTICE: .....	2	10.1 PRE-OPERATIONAL CHECKLIST.....	15
<b>2. CONTENTS</b>		10.2 STARTING THE GENERATOR ..	15
2.1 TABLE OF CONTENTS.....	3	10.3 STOPPING THE GENERATOR .....	16
<b>3. WARRANTY</b>		10.4 OVERLOAD CUT-OUT FOR SOCKET-OUTLETS .....	16
3.1 WARRANTY .....	4	10.5 AC APPLICATIONS .....	16
<b>4. INTRODUCTION</b>		10.6 DC POWER.....	17
4.1 SCOPE .....	5	10.7 INDICATOR LIGHTS .....	17
4.2 SPECIFICATION .....	5	<b>11. MAINTENANCE AND TROUBLESHOOTING</b>	
4.3 HANDLING AND STORAGE .....	6	11.1 THE IMPORTANCE OF MAINTENANCE.....	18
<b>5. HEALTH AND SAFETY INFORMATION</b>		11.2 MAINTENANCE SCHEDULE .....	18
5.1 GENERAL SAFETY INSTRUCTIONS FOR POWER TOOL USE.....	7	11.3 AIR CLEANER SERVICE .....	19
5.2 ADDITIONAL SAFETY INSTRUCTIONS FOR GENERATOR USE .....	8	11.4 SPARK PLUG .....	19
5.3 RESIDUAL RISK.....	9	11.5 CHECKING OIL LEVEL & CHANGING OIL.....	20
<b>6. TECHNICAL DESCRIPTION</b>		11.6 FUEL TANK FILTER .....	20
6.1 IDENTIFICATION – MAIN FEATURES.....	10	11.7 TROUBLESHOOTING.....	20
6.2 IDENTIFICATION – SWITCH PANEL .....	11	<b>12. DISPOSAL</b>	
<b>7. UNPACKING AND CHECKING</b>		12.1 DISPOSAL.....	21
7.1 PACKAGING.....	11	<b>13. EXPLANATION OF SYMBOLS</b>	
7.2 WHAT'S IN THE BOX.....	11	13.1 EXPLANATION OF SYMBOLS ..	22
<b>8. ASSEMBLY</b>			
8.1 ATTACHING THE TRANSPORT WHEELS.....	12		
8.2 ATTACHING THE SUPPORT FEET .....	12		
8.3 ATTACHING THE TRANSPORT HANDLES.....	12		
<b>9. PREPARING THE GENERATOR</b>			
9.1 CONNECTING TO EARTH .....	13		
9.2 HANDLING & STORAGE .....	13		

## 3. WARRANTY

---

### 3.1 WARRANTY

Draper tools have been carefully tested and inspected before shipment and are guaranteed to be free from defective materials and workmanship.

Should the tool develop a fault, please return the complete tool to your nearest distributor or contact:

**Draper Tools Limited, Chandler's Ford, Eastleigh, Hampshire, SO53 1YF. England.**

**Telephone Sales Desk: +44 (0) 8049 4333 or Product Help Line +44 (0) 23 8049 4344.**

A proof of purchase **must** be provided with the tool.

If upon inspection it is found that the fault occurring is due to defective materials or workmanship, repairs will be carried out free of charge. This warranty period covering labour is 12 months from the date of purchase except where tools are hired out when the warranty period is 90 days from the date of purchase. The warranty is extended to 24 months for parts only. This warranty does not apply to any consumable parts, any type of battery or normal wear and tear, nor does it cover any damage caused by misuse, careless or unsafe handling, alterations, accidents, or repairs attempted or made by any personnel other than the authorised Draper warranty repair agent.

**Note:** If the tool is found not to be within the terms of warranty, repairs and carriage charges will be quoted and made accordingly.

This warranty applies in lieu of any other warranty expressed or implied and variations of its terms are not authorised.

Your Draper warranty is not effective unless you can produce upon request a dated receipt or invoice to verify your proof of purchase within the warranty period.

Please note that this warranty is an additional benefit and does not affect your statutory rights.

**Draper Tools Limited.**

## 4. INTRODUCTION

---

### 4.1 SCOPE

This manual is intended to give an overview of the functioning and controls of the machine to aid in its safe use.

### 4.2 SPECIFICATION

Stock No. ....	98683
Part No. ....	PG4000
Engine type.....	Four cycle OHV
Displacement.....	212cc
Rated power .....	3800W
Rated current.....	16A
Max power .....	4000W
Cooling system.....	Forced air
Output sockets:	
Rated AC .....	2 × 230V
Rated AC frequency .....	50Hz
12V @ 5.0A (2 × 1.0A USB) .....	DC 5V@2A(2×1.0A USB)
Performance class.....	G1
Grade.....	A
Oil capacity .....	0.6L
Engine oil.....	SAE 15W-40
Fuel tank capacity.....	5.0L
Fuel type.....	Unleaded petrol (RON95)
Noise level 4M .....	96dB(A)
Uncertainty (K) .....	3dB(A)
Altitude.....	1000m
Max. ambient temperature.....	40°C
Dimensions (L×W×H) .....	500 × 350 ×485mm
Weight .....	28.5kg nett / 31kg gross

### 4.3 HANDLING AND STORAGE

**Caution:** Always use and store this generator correctly, never use or store this generator on it's

## 4. INTRODUCTION

---

side as oil or fuel may leak and damage the generator or your property.

If the generator has been used always allow it to cool for at least 30 minutes before transporting the generator and ensure that the generator has fully cooled before returning it to storage as a hot engine and exhaust system could cause personal injury or ignite some materials.

To prevent fuel/oil spillage when transporting, the generator should be secured upright in it's normal operating position with the engine switch in the off position.

Take care not to drop or strike the generator when transporting. Never cover the generator when in use.

Before storing the generator for a long period:-

1. Be sure that the storage area is free of excessive humidity and dust.
2. Drain the fuel, storage procedure below.
  - A. Unscrew the fuel tank cap, remove the filter screen and empty the fuel tank into an approved petrol container using a commercially available hand siphon (Draper Stock No.43650), re-install the filter screen and fuel tank cap.
  - B. Loosen the carburettor drain screw and drain the carburettor into a suitable container.
  - C. Remove the spark plug maintenance cover and remove the spark plug cap.
  - D. Turn the engine switch to the OFF position.

## 5. HEALTH AND SAFETY INFORMATION

---

### 5.1 GENERAL SAFETY INSTRUCTIONS FOR POWER TOOL USE

When using any type of power tool there are steps that should be taken to make sure that you, as the user, remain safe.

Common sense and a respect for the tool will help reduce the risk of injury.

**Read the instruction manual fully.** Do not attempt any operation until you have read and understood this manual.

Most important you must know how to safely start and stop this machine, especially in an emergency.

**Keep the work area tidy and clean.** Attempting to clear clutter from around the machine during use will reduce your concentration. Mess on the floor creates a trip hazard. Any liquid spilt on the floor could result in you slipping.

**Find a suitable location.** If the machine is bench mounted, the location should provide good natural light or artificial lighting as a replacement. Avoid damp and dust locations as it will have a negative effect on the machine's performance. If the machine is portable do not expose the tool to rain. In all cases do not operate power tools near any flammable materials.

**Keep bystanders away.** Children, onlookers and passers by must be restricted from entering the work area for their own protection. The barrier must extend a suitable distance from the tool user.

Unplug and house all power tools that are not in use. A power tool should never be left unattended while connected to the power supply. They must be housed in a suitable location, away locked up and from children. This includes battery chargers.

**Do not overload or misuse the tool.** All tools are designed for a purpose and are limited to what they are capable of doing. Do not attempt to use a power tool (or adapt it in any way) for an application it is not designed for. Select a tool appropriate for the size of the job. Overloading a tool will result in tool failure and user injury. This covers the use of accessories.

**Dress properly.** Loose clothing, long hair and jewellery are all dangerous because they can become entangled in moving machinery. This can also result in parts of body being pulled into the machine. Clothing should be close fitted, with any long hair tied back and jewellery and neck ties removed. Footwear must be fully enclosed and have a non-slip sole.

**Wear personal protective equipment (PPE).** Dust, noise, vibration and swarf can all be dangerous if not suitably protected against. If the work involving the power tool creates dust or fumes wear a dust mask. Vibration to the hand, caused by operating some tools for longer periods must be protected against. Wear vibration reducing gloves and allow long breaks between uses. Protect against dust and swarf by wearing approved safety goggles or a face shield. These are some of the more common hazards and preventions, however, always find out what hazards are associated with the machine/work process and wear the most suitable protective equipment available.

**Do not breathe contaminated air.** If the work creates dust or fumes connect the machine (if possible) to an extraction system either locally or remotely. Working outdoors can also help if possible.

**Move the machine as instructed.** If the machine is hand held, do not carry it by the power supply cable. If the product is heavy, employ a second or third person to help move it safely or use a mechanical device. Always refer to the instructions for the correct method.

**Do not overreach.** Extending your body too far can result in a loss of balance and you falling. This could be from a height or onto a machine and will result in injury.

**Maintain your tools correctly.** A well maintained tool will do the job safely. Replace any damaged or missing parts immediately with original parts from the manufacturer. As applicable, keep blades sharp, moving parts clean, oiled or greased, handles clean, and emergency devices working.

**Wait for the machine to stop.** Unless the machine is fitted with a safety brake, some parts may continue to move due to momentum. Wait for all parts to stop, then unplug it from the power supply

## 5. HEALTH AND SAFETY INFORMATION

---

before making any adjustments, carrying out maintenance operations or just finishing using the tool.

**Remove and check setting tools.** Some machinery requires the use of additional tools or keys to set, load or adjust the power tool. Before starting the power tool always check to make certain they have been removed and are safely away from the machine.

**Prevent unintentional starting.** Before plugging any machine in to the power supply, make sure the switch is in the OFF position. If the machine is portable, do not hold the machine near the switch and take care when putting the machine down, that nothing can operate the switch.

**Carefully select an extension lead.** Some machines are not suitable for use with extension leads. If the tool is designed for use outdoors, use an extension lead also suitable for that environment. When using an extended lead, select one capable of handling the current (amps) drawn by the machine in use. Fully extend the lead regardless of the distance between the power supply and the tool. Excess current (amps) and a coiled extension lead will both cause the cable to heat up and can result in fire.

**Concentrate and stay alert.** Distractions are likely to cause an accident. Never operate a power tool if you are under the influence of drugs (prescription or otherwise), including alcohol or if you are feeling tired. Being disorientated will result in an accident.

**Have this tool repaired by a qualified person.** This tool is designed to conform to the relevant international and local standards and as such should be maintained and repaired by someone qualified, using only original parts supplied by the manufacturer. This will ensure the tool remains safe to use.

### 5.2 ADDITIONAL SAFETY INSTRUCTIONS FOR GENERATOR USE

**Note:** Generators are designed to give safe and dependable service if operated according to instructions. Read and understand this owners manual fully before operating this generator. You can help prevent accidents by being familiar with the generators controls and by observing safe operating procedures.

#### **Operator responsibility**

- Know how to stop the generator quickly in case of emergency.
- Understand the use of all the generators controls, output sockets and connections.
- Be sure that anyone who operates the generator receives proper instruction in it's safe use.

#### **Warning! Carbon monoxide hazards**

- Exhaust gases contain poisonous carbon monoxide, a colourless and odourless gas.
- Breathing carbon monoxide can cause loss of consciousness and may lead to death.

**NEVER** run this generator in an enclosed space or partly enclosed space.

**ALWAYS** ensure a high level of ventilation in the area that you intend to use the generator to avoid the potential build up of carbon monoxide.

#### **Warning! Electric shock hazards**

- The generator produces enough electric power to cause a serious shock or electrocution if misused.
- Using a generator or electrical appliance in wet conditions, such as rain or snow, or near a pool or sprinkler system, or when your hands are wet, could result in electrocution. Keep the generator dry.
- If the generator is stored outdoors, unprotected from the weather, check all of the electrical components on the control panel before each use. Moisture or ice can cause a malfunction or short circuit in electrical components which could result in electrocution.
- Do not connect to a building electrical system unless an isolation switch has been installed by a qualified electrician.
- Never connect different generator models and types.



## 5. HEALTH AND SAFETY INFORMATION

---

### **Warning! Fire and burn hazards**

- The exhaust system gets hot enough to ignite some materials.
- Keep the generator at least 3 feet (1 metre) away from buildings and other equipment during operation.
- Do not enclose the generator in any structure.
- Keep flammable materials away from the generator.
- The muffler becomes very hot during operation and remains hot for a while after stopping the engine. Be careful not to touch the muffler while it is hot. Let the engine cool before storing the generator indoors.
- Petrol is extremely flammable and is explosive under certain conditions. Do not smoke or allow flames or sparks where the generator is refuelled or where petrol is stored. Refuel in a well-ventilated area with the engine stopped.
- Fuel vapours are extremely flammable and may ignite after the engine has started. Make sure that any spilled fuel has been wiped up before starting the generator.

### **5.3 RESIDUAL RISK**

**Important:** Although the safety instructions and operating manuals for our tools contain extensive instructions of safe working with power tools, every power tool involves a certain residual risk which can not be completely excluded by safety mechanisms. Power tools must therefore always be operated with caution!

# 6. TECHNICAL DESCRIPTION

## 6.1 IDENTIFICATION – MAIN FEATURES

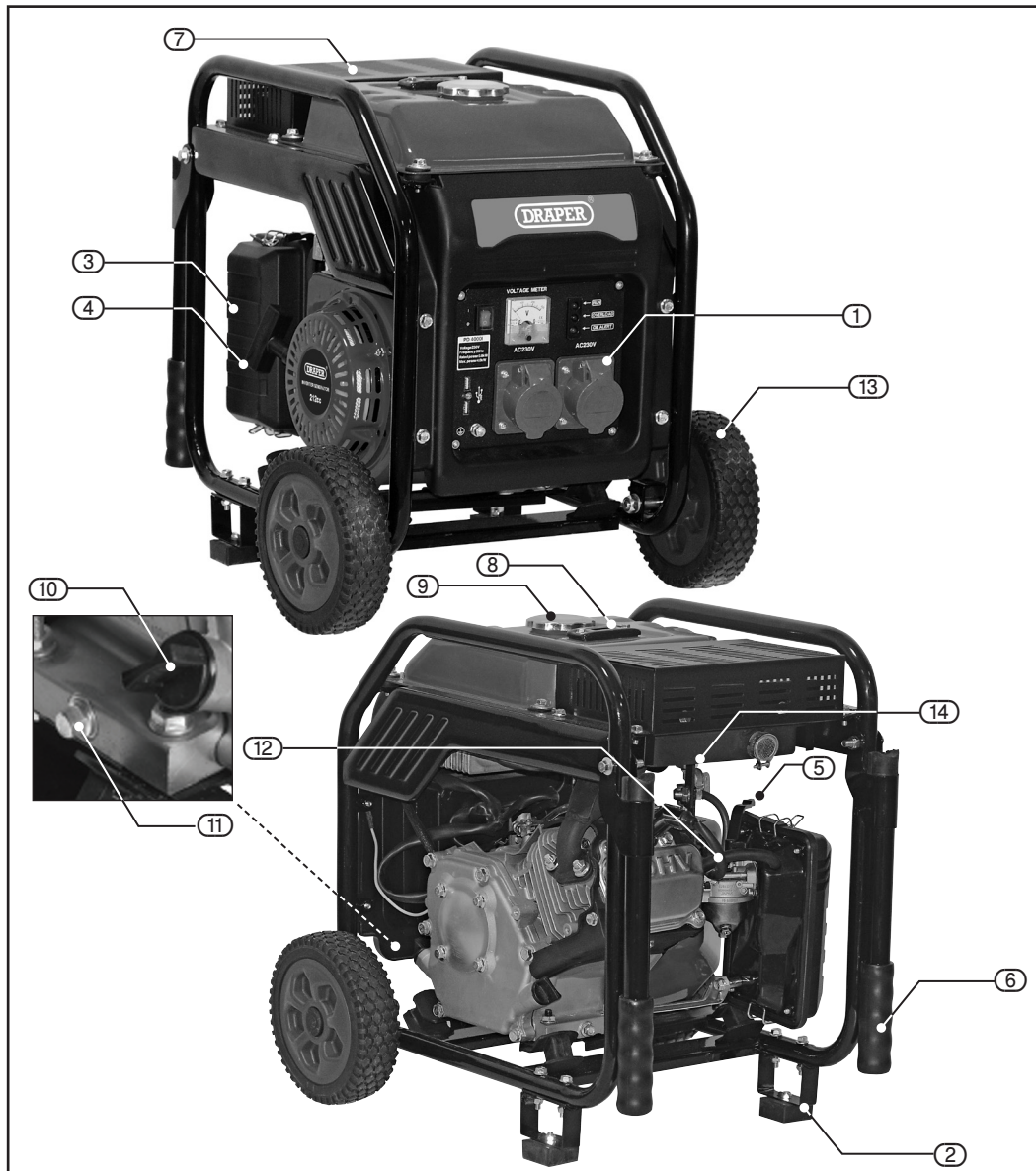

① 230V AC socket outlets.

② Support feet.

③ Air filter.

④ Pull cord.

⑤ Choke lever.

⑥ Transport handles.

⑦ Radiator plate

⑧ Fuel level Indicator

⑨ Fuel cap.

⑩ Oil filler cap/dipstick.

⑪ Oil drain plug.

⑫ Spark plug cable.

⑭ Fuel cock.

## 6. TECHNICAL DESCRIPTION

### 6.2 IDENTIFICATION – SWITCH PANEL

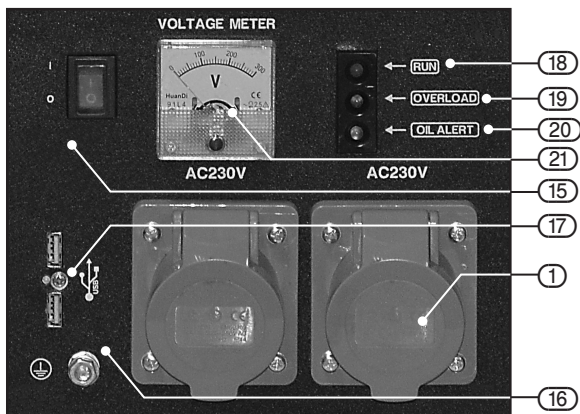

- ① 230V AC socket outlets.
- ⑮ ON/OFF switch.
- ⑯ Earthing point.
- ⑰ 12V DC/USB outlets.
- ⑱ Operational light.
- ⑲ Overload warning light.
- ⑳ Oil pressure warning light.
- ㉑ Voltage meter.

## 7. UNPACKING AND CHECKING

### 7.1 PACKAGING

Carefully remove the product from the packaging and examine it for any sign of damage that may have happened during shipping. Lay the contents out and check them against the parts shown below. If any part is damaged or missing, please contact the Draper Help Line (the telephone number appears on the Title page) and do not attempt to use the product.

The packaging material should be retained at least during the warranty period, in case the machine needs to be returned for repair.

#### Warning!

- Some of the packaging materials used may be harmful to children. Do not leave any of these materials in the reach of children.
- If any of the packaging is to be thrown away, make sure they are disposed of correctly, according to local regulations.

### 7.2 WHAT'S IN THE BOX

As well as the main product, there are several parts not fitted or attached to it.

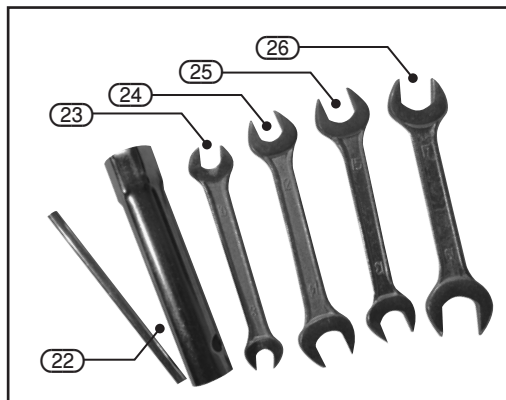

- ㉒ Spark plug box spanner.
- ㉓ 8 x 10mm Open ended spanner.
- ㉔ 12 x 14mm Open ended spanner.
- ㉕ 13 x 15mm Open ended spanner.
- ㉖ 17 x 19mm Open ended spanner.

**Note:** For details of our full range of accessories and consumables, please visit [drapertools.com](http://drapertools.com)

## 8. ASSEMBLY

### 8.1 ATTACHING THE TRANSPORT WHEELS – FIG.1

**Note:** The wheels are not intended for on-road use.

- Slide the wheel axle (13.2) through the holes in the wheel brackets (13.1) mounted on the frame.
- Use the supplied fixings in conjunction with the appropriate sized supplied spanner (23) - (26) to secure the wheel in place.
- Repeat the above steps with the other transport wheel.

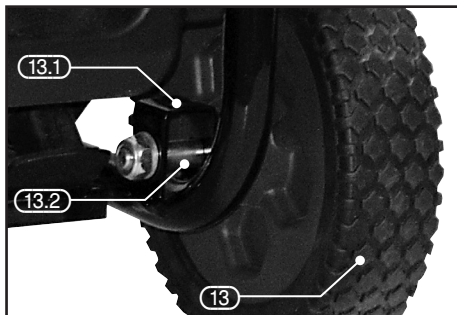

FIG.1

### 8.2 ATTACHING THE SUPPORT FEET – FIG.2

Using the photograph shown in FIG.2 for reference:

- Attach the rubberised foot (2.1) to the foot support bracket (2.2) using the supplied fixings.
- Align the assembled foot support with the holes in the lower framework (2.3).
- Tighten the support foot to the frame using the appropriate sized spanner supplied (23) - (26).
- Repeat the above steps to assemble the other support foot.

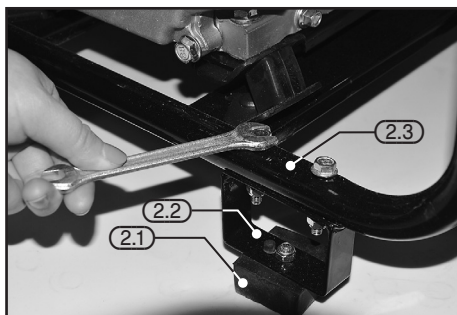

FIG.2

### 8.3 ATTACHING THE TRANSPORT HANDLES – FIGS.3 – 4

Using the photographs shown in FIGS.2 – 3 for reference:

- Align the support handles (6) with the corresponding holes located on generator frame
- Secure in place using the appropriate fixings and the appropriate sized spanner supplied (23) - (26).

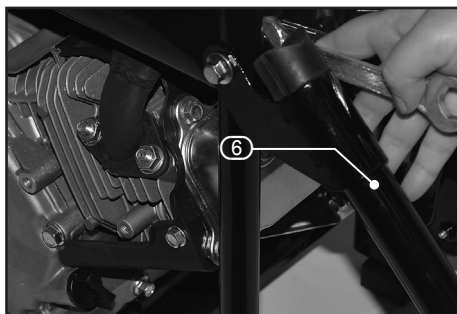

FIG.3

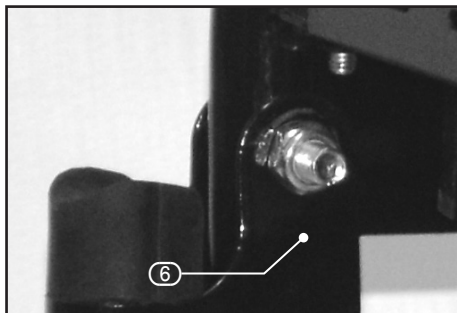

FIG.4

## 9. PREPARING THE GENERATOR

### 9.1 CONNECTING TO EARTH – FIG.5

The generator must be earthed to discharge static electricity. Attach a cable to the connection (16) on the faceplate, the other end to external earth (for example an earth rod which can be purchased at your local camping supplier).

Earthing of generators is covered in BS7430:2011. If you have any doubts about this subject consult a qualified electrician.

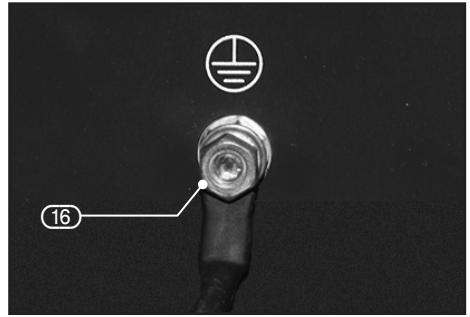

FIG.5

### 9.2 HANDLING & STORAGE

**Warning!** Petrol is highly flammable and explosive. You can be burned or seriously injured when handling fuel.

- Keep heat, sparks and flame away.
- Handle fuel outdoors only.
- Wipe up spills immediately.

If storing this machine for a prolonged time there are some procedures to follow to prepare the machine prior to storage:

- Remove any fuel from the fuel tank by using a siphon. Loosen the carburettor drain screw and drain remaining fuel into a suitable container prior to correct disposal of old fuel (check local regulations).
- Check the machine over and repair or replace any worn or damaged parts.
- Remove the spark plug and pour about a tablespoon of clean engine oil into the cylinder.
- Crank the engine several revolutions to distribute the oil, then re-install the spark plug.
- Re-install the spark plug cap on the spark plug securely.
- Pull the starter grip slowly until you feel resistance, then return the starter grip gently. This closes the valves so moisture cannot enter.

**Warning!** The generator is shipped without oil in the engine. You **MUST** add the required amount of oil before trying to start the engine.

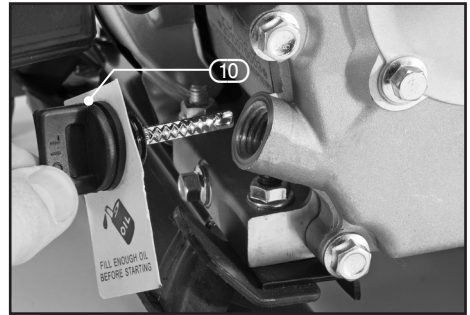

FIG.6

### 9.3 ADDING ENGINE OIL – FIG. 6

- With the generator on a level surface, remove the oil filler cap/dipstick (10).
- Add exactly: 0.6L (15W-40 SAE 40).

**Warning!** Do not overfill the engine with oil

If the engine is overfilled, the excess oil may be transferred to and contaminate the air filter and it's housing.

- Screw in the filler cap/dipstick (16) securely.

**Caution:** prolonged exposure to used engine oil is dangerous, always wash your hands thoroughly after handling used engine oil.

#### **Environmental protection**

One of the most damaging sources of pollution is oil. Do not throw away used engine oil in with your domestic waste or down drains and sinks. Place it in a leak proof container and dispose of it according to local regulations.

## 9. PREPARING THE GENERATOR

### 9.4 ADDING FUEL – FIG.5

- Remove fuel cap (9) fill with unleaded petrol (RON95), do not over fill, allow room for fuel expand when it heats up. Replace cap.
- Never use stale or contaminated petrol or an oil/petrol mixture. Avoid getting dirt or water in the fuel tank.
- If the fuel level is low, refuel in a well-ventilated area with the engine stopped.
- If the engine has been running, allow it to cool first.

**Warning!** Never refuel the engine inside a building where petrol fumes can reach flames or sparks.

**Warning!** Petrol is highly flammable and explosive.

You can be burned or seriously injured when handling fuel.

- Stop the engine and keep heat, sparks and flames away.
- Handle fuel only outdoors.
- Wipe up spills immediately.

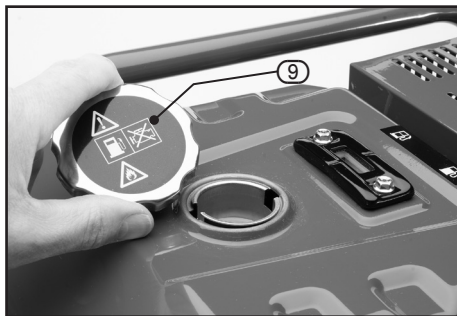

FIG.7

# 10. OPERATING INSTRUCTIONS

## 10.1 PRE-OPERATIONAL CHECKLIST

Before starting the generator:

- You **MUST** fill up with engine oil and fuel before you can start the engine.
- Check the fuel level and top it up if necessary.
- Make sure that the generator has sufficient ventilation.
- Make sure that the ignition cable is secured to the spark plug.
- Inspect the immediate vicinity of the generator.
- Disconnect any electrical equipment which may already been connected to the generator.
- Permissible ambient temperature -10 to 40°C, max. altitude above sea level 1000M.

**Warning!** For your safety **DO NOT** operate the generator in an enclosed area such as a garage. The generator's exhaust emits toxic gases containing poisonous carbon monoxide which can cause unconsciousness and even death in high concentrations.

## 10.2 STARTING THE GENERATOR – FIGS. 8 – 11

**Note:** Before connecting loads/appliances to the generator, be sure to read the chapters on AC OPERATION and DC OPERATION that follow this section.

**Note:** Prior to each starting of the machine, perform the pre-operational checklist above.

- Open the fuel cock (14) by turning it down.
- Turn the engine switch (15) to the “ON” position.
- Move the choke lever (5) to the “CHOKE” position to start the engine from cold.

**Note:** The choke is not required to start a warm engine.

- Pull the starter cord (4) gently until you feel resistance then give a brisk pull on the starter cord, several pulls on the starter cord may be required to start the engine.

**Note:** Do not allow the extended starter cord to snap back against the engine casing as damage to the starter or housing can occur.

- If the choke lever was moved to the “CHOKE” position to start the engine from cold, gradually move it to the “Run” position as the engine warms up.

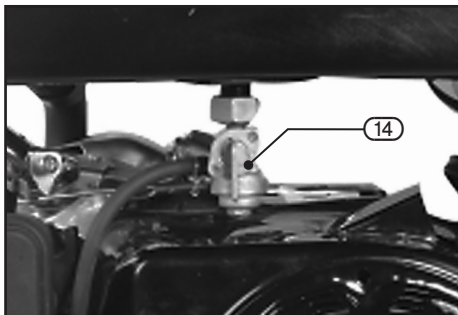

FIG.8

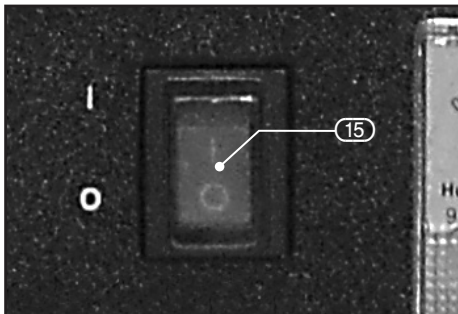

FIG.9

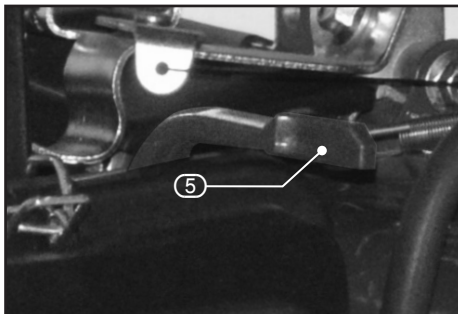

FIG.10

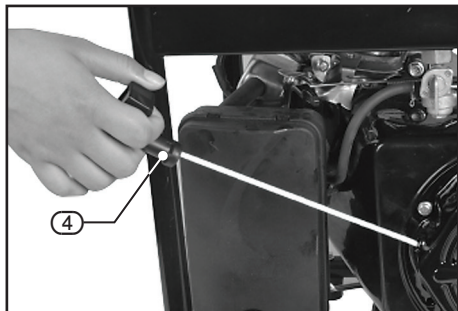

FIG.11

# 10. OPERATING INSTRUCTIONS

## 10.3 STOPPING THE GENERATOR – FIGS.12 – 13

To stop the engine in an emergency, switch the engine on/off switch to off.

Under normal operating conditions, use the procedure detailed below to stop the generator:-

- Unplug any appliances and/or charging batteries from the generator, if the generator has been working hard allow it to idle for a short time.
- Switch the engine ON/OFF switch (15) to off.
- Turn fuel cock off (14).
- Allow the engine to fully cool before transporting or returning to storage.

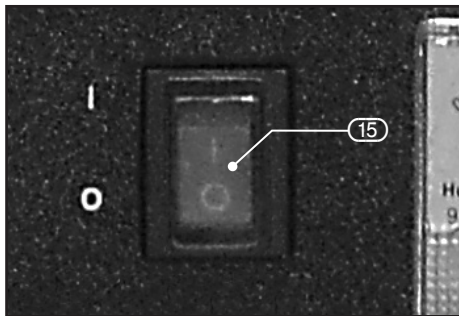

FIG.12

## 10.4 OVERLOAD CUT-OUT FOR SOCKET-OUTLETS – FIG.14

**Important:** The generator is equipped with an electronic overload protection which switches off the sockets in case of overload.

When the overload cut-off is displayed, turn off the power generator and remove the connected equipment from the generator. This will reset the overload cut-off and allow you to turn the generator back on.

**Important:** If this happens, reduce the electric power you are taking from the generator or remove any defective connected appliances.

**Important:** Defective overload cut-outs must be replaced only by overload cut-outs of identical design and with the same performance data. If repairs are necessary, please contact your customer service centre.

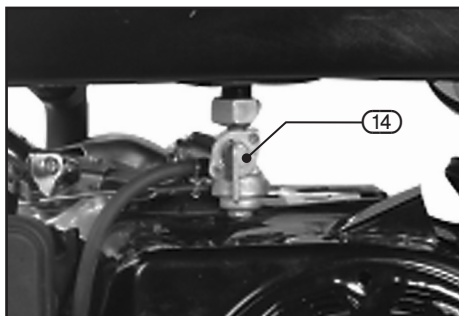

FIG.13

## 10.5 AC APPLICATIONS

Before connecting an appliance or power cord to the generator:-

**Note:** Allow 2-3 minutes after starting the generator to allow the generator to settle before connecting AC appliances and using the throttle economy switch.

1. Make sure that it is in good working order. Faulty appliances or power cords can create the potential for electric shock.
2. If an appliance begins to operate abnormally in any way, turn it off immediately and disconnect it from the generator and check that the appliance does not exceed the generators maximum rating.

Always make sure that the appliances power rating does not exceed the generator's maximum rating.

In either case the total power requirements (VA) of all appliances connected must be considered. The above limits must not be exceeded.

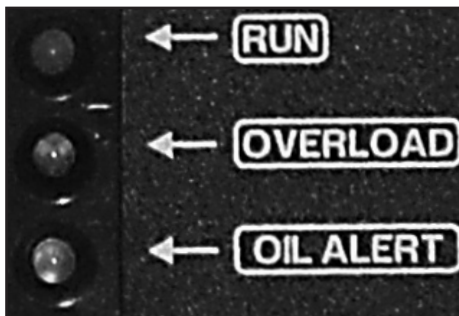

FIG.14



# 10. OPERATING INSTRUCTIONS

When powering sensitive electronics it is advisable to only power a single appliance at a time.

**Note:** Substantial overloading will switch off the engine. Exceeding the limits for maximum power operation or slightly overloading the generator may not switch off the generator but will shorten the service life of the generator.

The AC output is Pure Sine Wave so it's safe for sensitive appliances such as laptops or appliances with a digital panel. It can also power induction plates and microwave ovens.

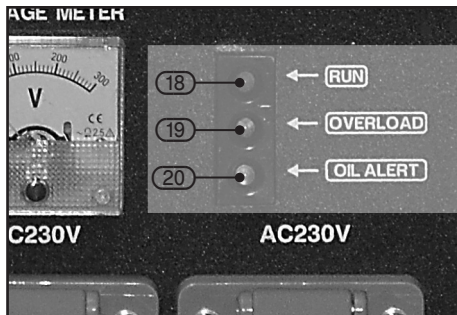

FIG.15

## 10.6 DC POWER

- Set the economy control switch to 'OFF'.
- Start the generator.
- Make sure the appliance is turned off before connecting it to the generator.
- Connect the 12V appliance (max. 4A) to the generator.

## 10.7 INDICATOR LIGHTS – FIG. 15

**RUN** indicator (18) (Green) will remain on during normal operation.

**OVERLOAD** indicator (19) (Red) will light up if there is an overload or a short circuit in the connected appliance.

If this happens, proceed as follows:

- Turn off any connected electrical devices and stop the engine.
- Reduce the total wattage of connected electric devices to within the rated output of the generator.
- Check air inlet and around the control unit. If any blockages are found, remove them.
- After checking, restart the engine.

**OIL ALERT** indicator (20)

The oil alert indicator (Red) will light up when the oil level is low.

# 11. MAINTENANCE AND TROUBLESHOOTING

## 11.1 THE IMPORTANCE OF MAINTENANCE

Good maintenance is essential for the safe, economical and trouble-free operation of the generator. It will also help reduce air pollution.

**Warning!** Improper maintenance, or failure to correct a problem before operation, can cause a malfunction in which could cause serious injury or death.

Always follow the inspection and maintenance recommendations and schedules in this owner's manual.

To help you to properly care for your generator, the following pages include a maintenance schedule, routine inspection procedures and simple maintenance procedures using basic hand tools. Other service tasks that are more difficult, or require special tools, are best handled by professionals and are normally performed by a technician or other qualified mechanic.

The maintenance schedule applies to normal operating conditions. If you operate your generator under severe conditions, such as sustained high-load or high temperature operation, or use it in usually wet or dusty conditions, consult your servicing dealer for recommendations applicable to your individual needs and use.

Remember that your servicing dealer knows your generator best and is fully equipped to maintain and repair it. To ensure the best quality and reliability, use only new, genuine Draper parts for repair or replacement.

## 11.2 MAINTENANCE SCHEDULE

Regular service period		Before each use	First month or 20 hours	Every 3 months or 50 hours	Every 6 months or 100 hours	Every 2 years or 300 hours
Item	Perform at every indicated month or operating hour interval, whichever comes first.					
Engine oil	Check level	●				
	Change		●	●		
Air cleaner	Check	●				
	Clean			● (1)		
Spark plug	Check/adjust			●		
	Replace				●	
Spark arrester	Clean				●	
Valve clearance	Check/adjust					● (2)
Combustion camber	Clean	After every 300 hrs. (2)				
Fuel tank and filter	Clean			● (2)		
Fuel line	Check	Every 2 years (replace if necessary) (2)				

(1) Service more frequently when used in dusty areas.

(2) These items should be serviced by your servicing dealer, unless the owner has the proper tools and is mechanically proficient. Failure to follow this maintenance schedule could result in non-warrantable failures.

# 11. MAINTENANCE AND TROUBLESHOOTING

## 11.3 AIR CLEANER SERVICE – FIGS. 16 – 17

A dirty air cleaner will restrict air flow to the carburettor. To prevent carburettor malfunction, service the air cleaner regularly. Service more frequently when operating the generator in extremely dusty areas.

**Caution!** Operating the engine without an air filter or with a damaged air filter will allow dirt to enter the engine, causing rapid engine wear.

This type of damage is not covered by the Draper warranty.

- Remove the air filter housing cover (3.1) by firstly pulling away the retaining clips (3.2).
- Remove the air filter element (3.3).

**Warning!** Using petrol or flammable solvent to clean the air filter can cause a fire or explosion.

- Use only soapy water or non-flammable solvent, once it is completely dry immerse the filter in clean engine oil and squeeze the filter to remove excess oil.

## 11.4 SPARK PLUG – FIG. 18

Remove and check spark plug for dirt and grime and if necessary clean with a copper wire brush.

- Twist off the spark plug boot and cable (12).
- Using the spark plug 'box' spanner (22) supplied, remove the spark plug.
- Check the spark plug gap with a feeler gauge, it should be between 0.6 and 0.7 mm.

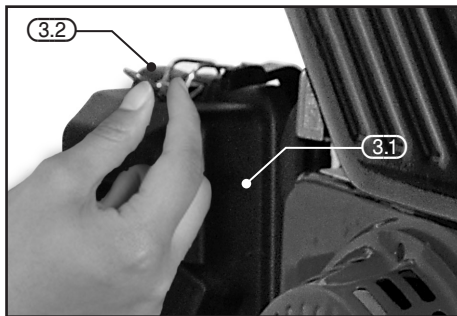
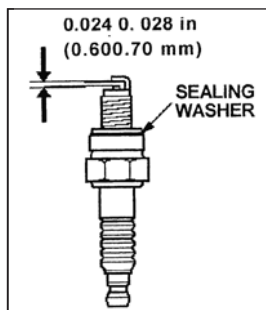

FIG.16

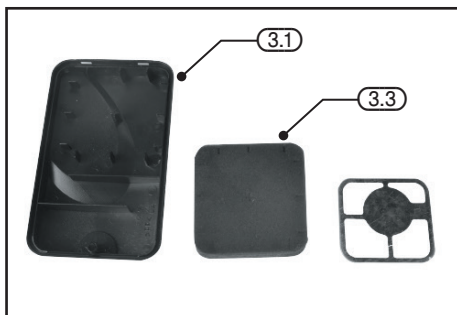

FIG.17

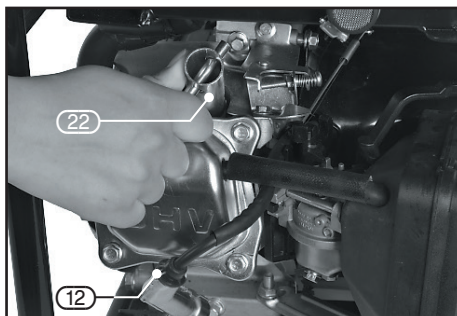

FIG.18

# 11. MAINTENANCE AND TROUBLESHOOTING

## 11.5 CHECKING OIL LEVEL & CHANGING OIL – FIG.18

- Place the generator on a slightly inclined surface so that the dip stick is at proper position.
- Screw off the oil filler plug and wipe away any oil on the dip stick.
- Put the oil dip stick back without screwing into the oil filler.

**Important:** Do not screw the dipstick in to check the oil level – simply insert it up to the thread.

- Check the dip stick; make sure the oil level is between 'high' and 'low' marks, as shown in Fig.18.

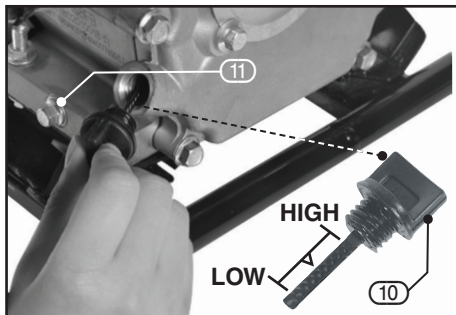

FIG.19

### Changing the engine oil

See also page 13: Section 9.3 ADDING ENGINE OIL

The motor oil is best changed when the motor is at working temperature.

- Only use motor oil (15W-40 SAE 40).
- Place the generator on a slightly inclined surface so that the oil drain plug is at the lower end.
- Open the oil filler plug (10).
- Open the oil drain plug (11) and let the hot engine oil drain out into a drip tray.
- After the old oil has drained out, close the oil drain plug and place the generator on a level surface again.

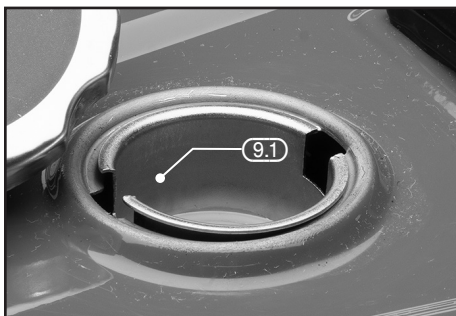

FIG.20

## 11.6 FUEL TANK FILTER – FIG.19

- Remove the fuel cap (9) and lift out the filter (9.1) – clean the filter with solvent.

## 11.7 TROUBLESHOOTING

Fault	Cause	Remedy
<b>Engine does not start</b>	<ul style="list-style-type: none"> <li>– Oil shortage cut-out has not responded</li> <li>– Spark plug fouled</li> <li>– No fuel</li> </ul>	<ul style="list-style-type: none"> <li>– Check oil level, top up engine oil</li> <li>– Clean or replace spark plug (electrode spacing 0.6-0.7 mm)</li> <li>– Refuel / check the fuel cock</li> </ul>
<b>Generator has too little or no voltage</b>	<ul style="list-style-type: none"> <li>– Controller or capacitor defective</li> <li>– Overload cut-off has triggered</li> <li>– Air filter dirty</li> </ul>	<ul style="list-style-type: none"> <li>– Contact your dealer</li> <li>– Actuate the circuit-breaker and reduce the consumers</li> <li>– Clean or replace the filter</li> </ul>

# 12. DISPOSAL

---

## 12.1 DISPOSAL

- At the end of the machine's working life, or when it can no longer be repaired, ensure that it is disposed of according to national regulations.
- Contact your local authority for details of collection schemes in your area.

In all circumstances:

- Do not dispose of power tools with domestic waste.
- Do not incinerate.
- Do not dispose of WEEE\* as unsorted municipal waste.



\* *Waste Electrical & Electronic Equipment.*

# 13. EXPLANATION OF SYMBOLS

## 13.1 EXPLANATION OF SYMBOLS



Read the instruction manual.



Wear ear defenders.



Do not abandon into the environment.



Keep out of the reach of children.



**Warning!**



**Warning!**  
Flammable material.



**Warning!**  
Very hot surfaces.



**Warning!**  
Risk of electrocution.



**Warning!**  
Risk of toxic fumes.



**Do not** operate the machine indoors.



**Do not** connect to socket outlets when performing maintenance.



**Do not** operate the machine without essential lubricating oil.



Keep your distance.



Must be earthed.



WEEE –  
Waste Electrical & Electronic Equipment.  
Do not dispose of Waste Electrical & Electronic Equipment in with domestic rubbish.



Continuous A-Weighted Sound Pressure Level.



UK Conformity Assessed.



European conformity.

# NOTES

---

## **CONTACTS**

Draper Tools Limited

UK: Hursley Road, Chandler's Ford, Eastleigh,  
Hampshire. SO53 1YF. U.K.

EU: Oude Graaf 8,  
6002 NL, Weert (NL).

Help Line: (023) 8049 4344

Sales Desk: (023) 8049 4333

Internet: [drapertools.com](http://drapertools.com)

E-mail: [sales@drapertools.com](mailto:sales@drapertools.com)

General Enquiries: (023) 8026 6355

Service/Warranty Repair Agent:

For aftersales servicing or warranty repairs, please contact the Draper Tools Help Line for details of an agent in your local area.

### **YOUR DRAPER STOCKIST**

RDCH1222

©Published by Draper Tools Limited.

No part of this publication may be reproduced, stored in a retrieval system or transmitted in any form or by any means, electronic, mechanical photocopying, recording or otherwise without prior permission in writing from Draper Tools Ltd.