

**DRAPER**  
*Expert*

20V BRUSHLESS

# IMPACT DRIVER



55944 - XP20ID200 SPARE PARTS DRAWING

**XP20**  
MULTI-TOOL BATTERY SYSTEM

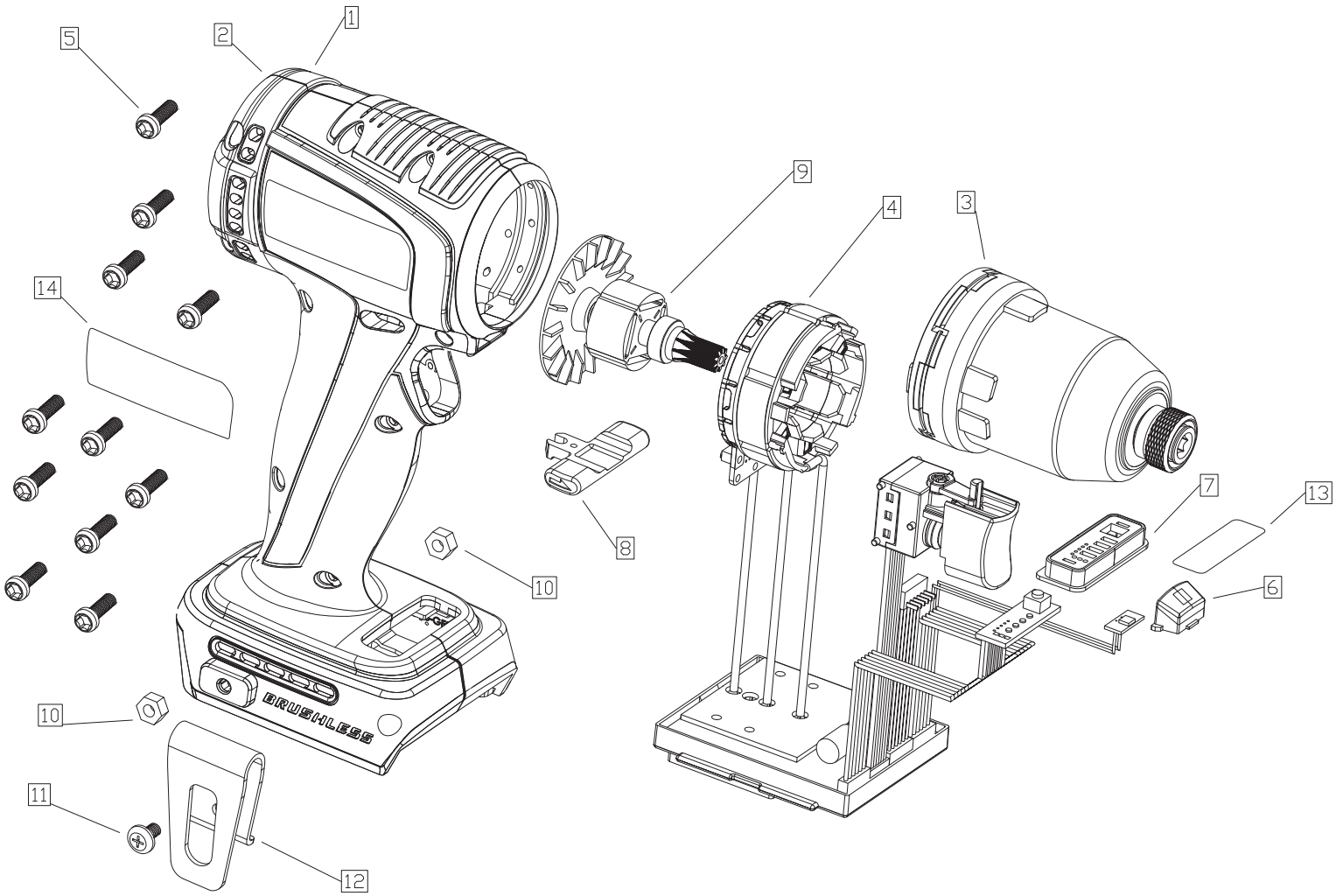

KEY No.	PART No.	STOCK No.	DESCRIPTION
1	YXP20IW1/23-1	98827	Right housing (ecopro Standard)
2	YXP20IW1/23-2	98828	Left housing (ecopro standard)
3	YXP20ID200-3	98843	Gear box assembly 1/4" (insertion 9.5mm)
4	YXP20ID200-4	98845	Motor stator assembly with controller
5	YXP20IW1/23-5	98832	Screw, 3*16, black
6	YXP20IW1/23-6	98833	Cover for LED light
7	YXP20IW1/23-7	98834	Speed/torque selector

KEY No.	PART No.	STOCK No.	DESCRIPTION
8	YXP20IW1/23-8	98835	Forward/reverse control button
9	YXP20IW1/23-9	98837	Motor rotor assembly (5010)
10	YXP20CD135-11	98819	Nut, M4
12	YXP20CD135-15	98825	Hook & screw assembly

Helpline: +44 (0) 23 8049 4344 Sales Desk: +44 (0) 23 8049 4333 General Enquiries: +44 (0) 23 8026 6355 internet: drapertools.com email: sales@drapertools.com